

# LVDT

## Inductive Position Transducer



### Series SL ø 20 mm

- *ranges 25...600 mm*
- *linearity up to 0,20 %*
- *housing ø 20 mm*
- *output: AC, 0...10 V, 0...5 V, 4...20 mA, 0...20 mA, ±10 V, ±5 V*
- *with external or integrated cable electronics*
- *rugged stainless steel housing*
- *temperature -40...+120 °C (150 °C on request)*
- *customised version available*

## TECHNICAL DATA

### sensor

measurement range FS [mm]	0...25	0...50	0...80	0...100	0...150	0...200	0...300	0...600
linearity [% of FS]	0,30 % (0,20 % optional); 1,50 % SL600							
types	free core, push rod guided/ unguided							
protection class	IP67, optional IP68							
vibration stability DIN IEC68T2-6	10 G							
shock stability DIN IEC68T2-27	200 G/ 2 ms							
supply voltage/ frequency	3 V <sub>eff</sub> / 3 kHz							
supply frequency	2...10 kHz							
temperature range	-40...+120 °C (150 °C optional, option H, 200 °C on request)							
mounting	∅ 20 mm clamp diameter or rod end bearings							
housing	stainless steel 1.4301							
connection	4 core cable or M12-connector with coupling nut							
cable TPE (standard)	∅ 4,5 mm, 0,14 mm <sup>2</sup> , non-halogen, suitable for drag chains							
PTFE (option H)	∅ 3,6 mm, 0,24 mm <sup>2</sup> , max. temperature 205 °C							
max. cable length	100 m between sensor and electronics							

### free core/ push rod/ push rod guided

max. acceleration of core/ push rod	100 G							
life time	infinite							
weight (approx., without cable) [g]	150	230	290	320	360	420	550	670

### electronics

#### IMCA external electronics (built-in)

#### KAB cable electronics

output signal	0...20 mA, 4...20 mA (load <100 Ohm) 0...5 V, ± 5 V (load >5 kOhm) 0...10 V, ± 10 V (load >10 kOhm)	4...20 mA (load <100 Ohm) 0...5 V, ± 5 V (load >5 kOhm) 0...10 V, ± 10 V (load >10 kOhm)
temperature coefficient	zero 150 ppm/ °C, max. value 400 ppm/ °C	460 ppm/ °C
ripple	< 0,5 mV <sub>eff</sub> up to 300 Hz, < 4 mV <sub>eff</sub> up to 20 MHz	< 0,5 mV <sub>eff</sub> up to 300 Hz, < 4 mV <sub>eff</sub> up to 20 MHz
max. frequency	300 Hz/ -3 dB (Bessel, 6-pole)	300 Hz/ -3 dB (Bessel, 6-pole)
isolation voltage	> 1000 VDC	> 1000 VDC
power supply	9...36 VDC	9...36 VDC
current consumption	75 mA at 24 VDC 150 mA at 12 VDC	65 mA at 24 VDC 140 mA at 12 VDC
sensor supply	3 V <sub>eff</sub> , 3 kHz (adjustable 1-18 kHz)	3 V <sub>eff</sub> , 3 kHz (adjustable 1-18 kHz)
working temperature	-40...+85 °C	-40...+85 °C
storage temperature	-40...+85 °C	-40...+85 °C
housing	polyamide PA6.6, meets UL94-VO	aluminium
mounting	on DIN EN-rail	-

The output signal is referring to the electric measuring range. If the sensor is operated outside the measuring range or the measuring range is exceeded, the signal is also outside the defined range (i.e. > 10 V/ 20 mA or < 0 V/ 4 mA, in the graph: > 100 % or < 0 %). Please keep this in mind for control systems with cable break detection lower than 4 mA or for a maximum input voltage > 10 V of measuring instruments. If necessary install the sensor **before** connecting to the plc.

Running direction of signal: If the push rod is moving into the sensor (e.g. sprung load pushed in), the signal is reducing. If the push rod is moving out, the output signal is increasing. The running direction of the signal can also be inverted.

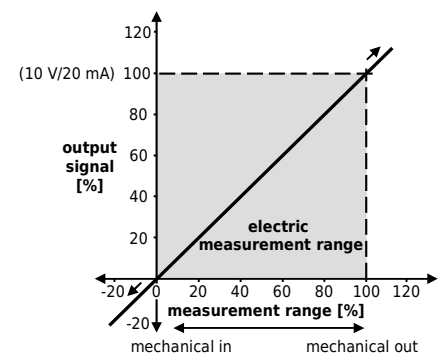

## TECHNICAL DIMENSIONS

range (FS) [mm]	body length A [mm]	core length B [mm]	push rod length C [mm]
0...25	137	67	127
0...50	187	70	177
0...80	247	100	237
0...100	287	120	277
0...150	387	170	377
0...200	487	220	477
0...300	687	320	677
0...600	905	240	657

Other measurement ranges are available on request.

type: free core, unguided push rod

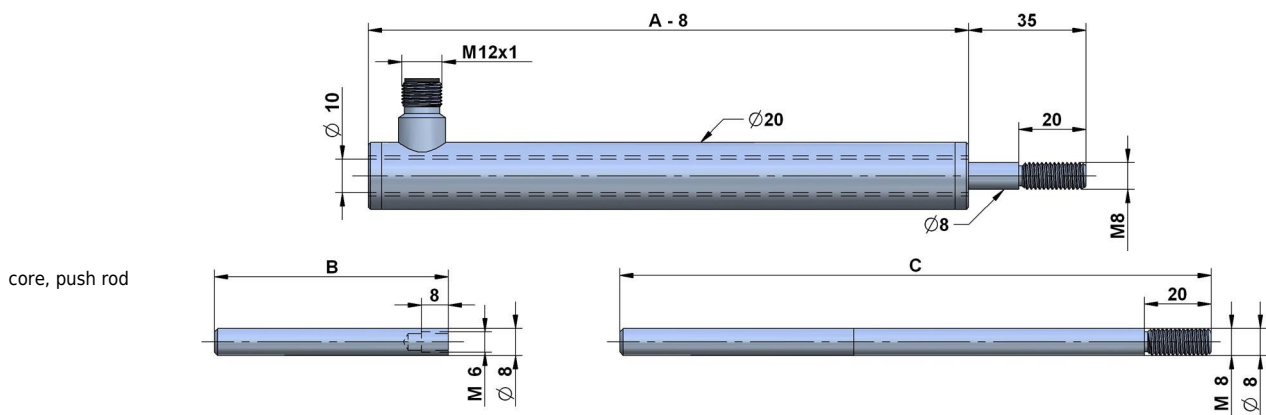

type: guided push rod

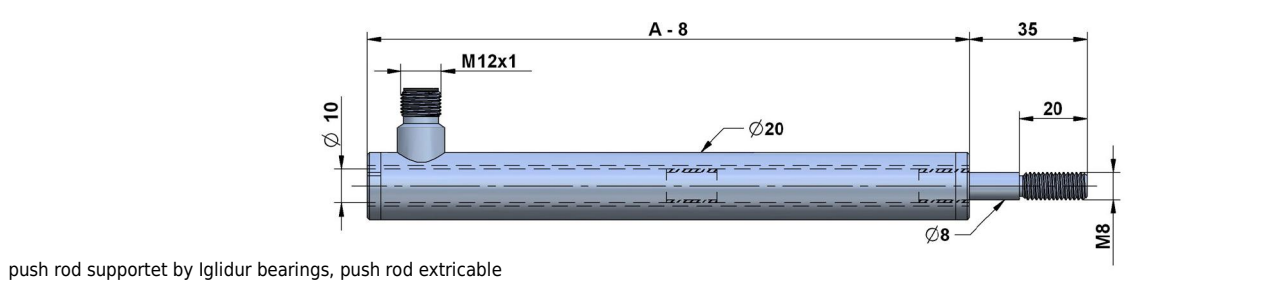

type: rod end bearings

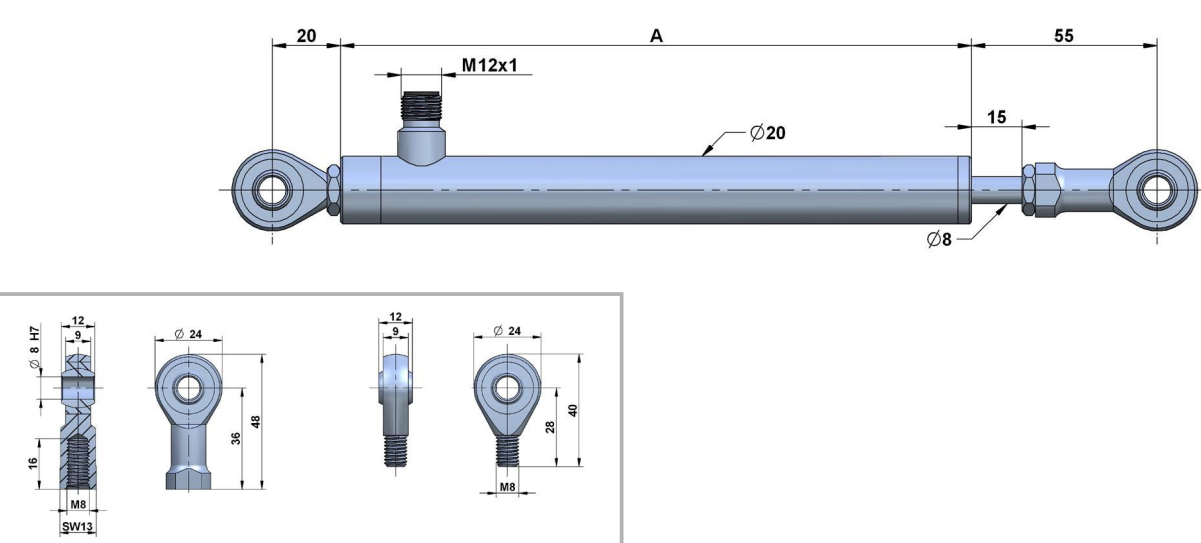

## SENSOR TYPES

### cable output radial

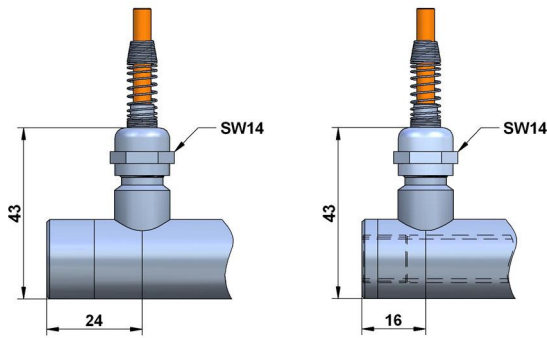

Sensors with cable output have a cable fitting and a spring for bend protection of the cable.

For installation, the bending radius should not be less than 3 times the cable diameter. The standard cable length is 2 m.

Instruments with option H for temperatures up to 150 °C feature a PTFE cable.

Sensors have a through hole. Please use this type for application at heavy dirt exposure. The movement of the push rod removes the dirt from the sensor and conveys it to the rear.

Depending on the application the sensor can - on request - be supplied with a closed rear end body (without additional charge). Please specify that in your order.

### connector output radial (cable with straight or angular connector)

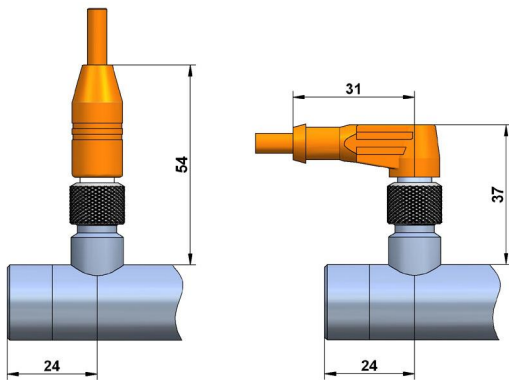

For sensors with connector output the cable has to be ordered separately. You can choose from a cable with a straight connector or with an angular connector.

The connector is protected from accidental removal by a threaded fitting (M12). The cable lengths are 2/ 5/ 10 m.

The connector pair has protection class IP67.

## ADJUSTMENT OF ZERO POINT AND GAIN

Please note that the zero point and gain may shift for long cable length between sensor and electronics. Thus install the sensor with the according cable length to the electronics and then adjust zero point and gain.

1. Push rod entirely in - adjust offset

Move the sensor to the zero point of the measuring range and set the offset potentiometer on 0 mA/ 0 V for the output signal.

2. Push rod entirely out - adjust gain

Move the sensor to the end of the measuring range (push rod moved out) and set the gain potentiometer on 16 mA / 10 V / 5 V for the output signal.

3. Adjust offset (4...20 mA output only).

Set the offset potentiometer on 20 mA (+4 mA) for the output signal.

Signal inversion:

If an inverted output signal is required (20...4 mA/ 10...0 V/ 5...0 V), swap clamps 6 and 8 (secondary coil) on the external electronics.

## AC-OUTPUT

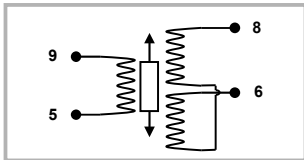

### assignment for TPE-cable:

white (5): primary 2  
 black (6): secondary 2  
 brown (9): primary 1  
 blue (8): secondary 1

### assignment for PTFE-cable:

white (5): primary 2  
 green (6): secondary 2  
 yellow (9): primary 1  
 brown (8): secondary 1

### assignment M12-connector:

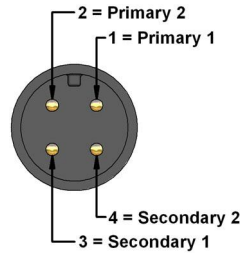

## CABLE ELECTRONICS KAB

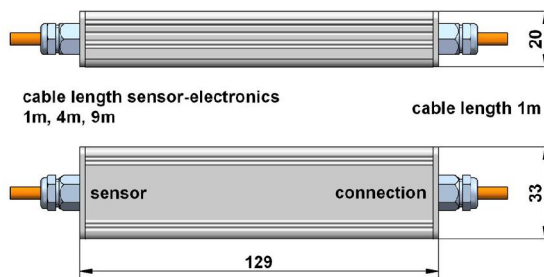

### assignment for TPE-cable:

brown: supply V+  
 blue: GND  
 black: output GND  
 white: output signal

### assignment for PTFE-cable:

yellow: supply V+  
 brown: GND  
 green: output GND  
 white: output signal

If not specified otherwise the cable electronics is placed at 1 m from the end of the cable. On request in your order, however, the cable electronics can be placed at any position.

## EXTERNAL ELECTRONICS IMCA



external electronics IMCA  
 (for DIN-rail mounting)

### dimensions:

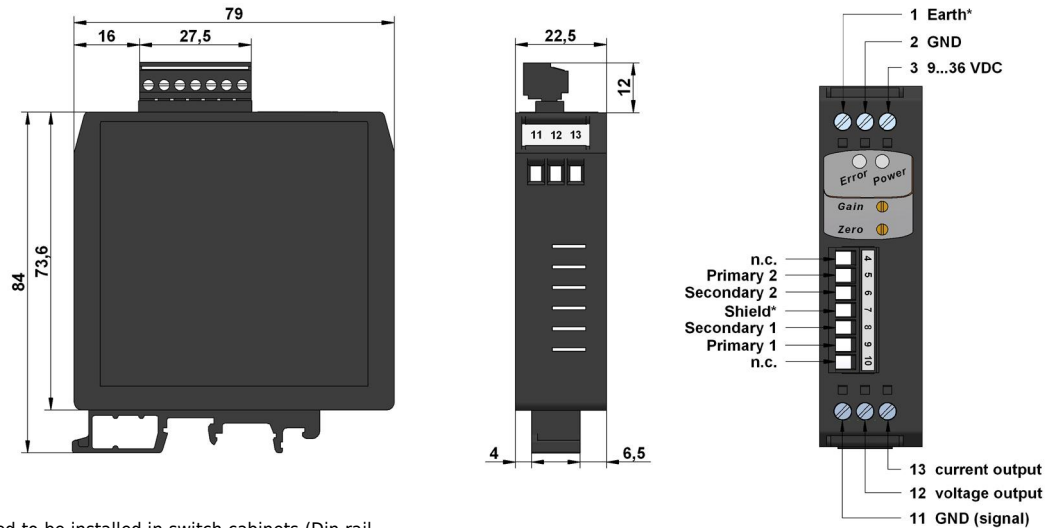

### Connection

The external electronics IMCA is designed to be installed in switch cabinets (Din-rail mounting). The connection to the sensor is conducted as connector with screw terminals.

\* Terminals 1 and 7 are internally connected.

At harsh EMC environments, it is possible to install the electronics at a max. distance of 100 m in a switch cabinet. A twin twisted pair cable (4-cores, minimum cross section 0,5 mm<sup>2</sup>), single or double shielded, is to be used for the further wiring to connect the external electronics to the system. It is recommended to ground the shield in the switch cabinet near the electronics (do not ground at the machine/ sensor). The sensor housing is grounded at the machine frame. To prevent interference, the cable length should not exceed 100 m.

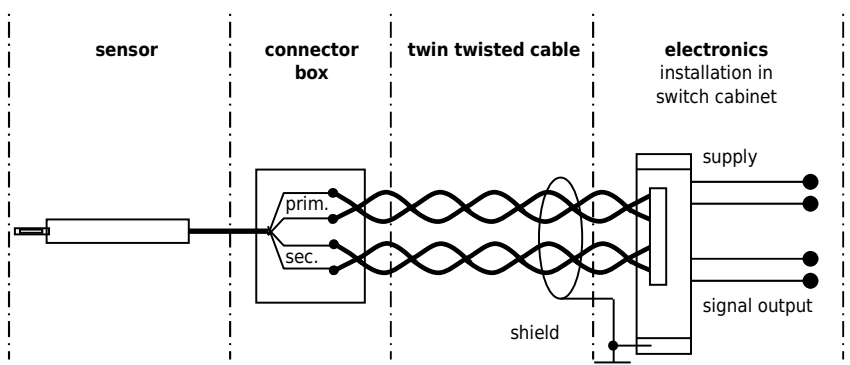

## ORDER CODE

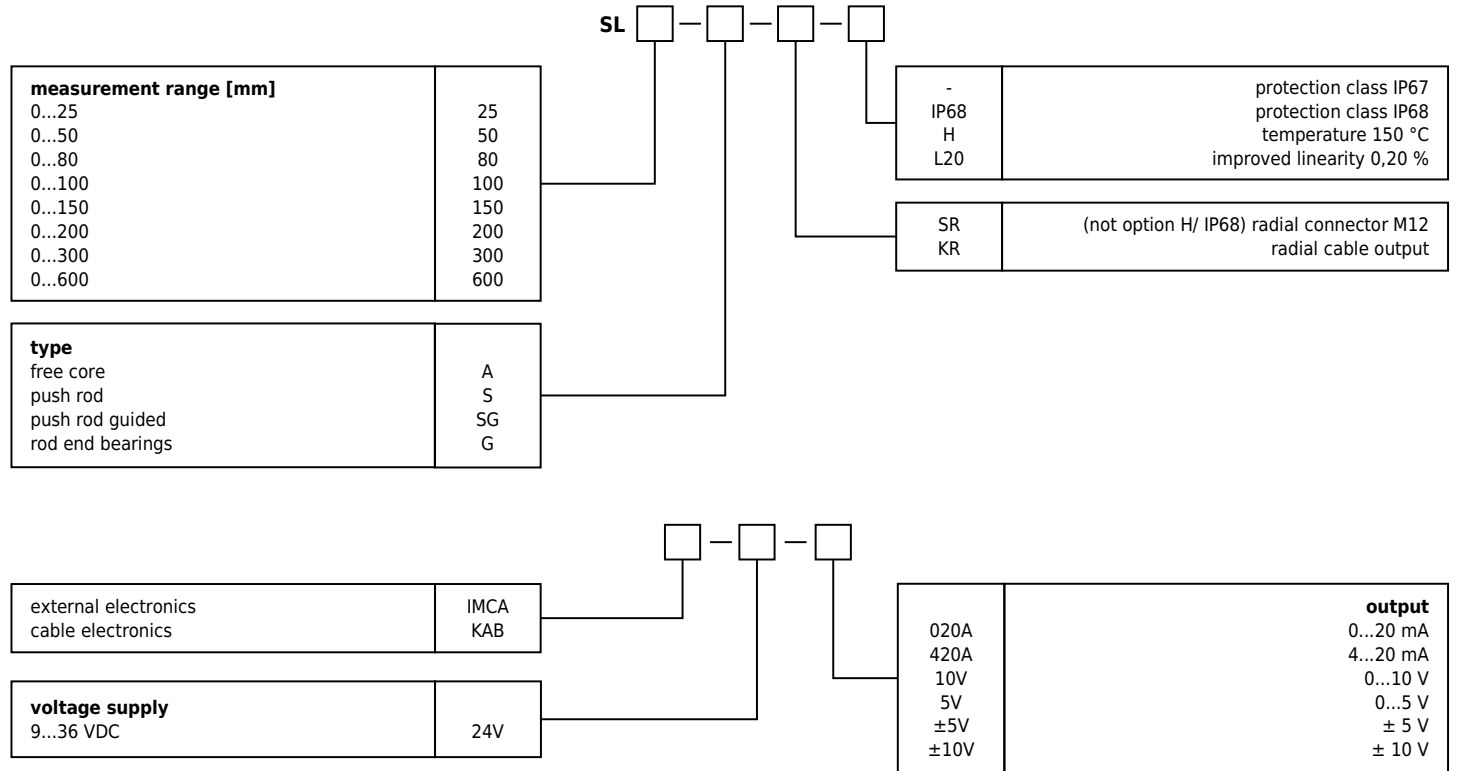

### Connector cable:

#### cable with straight connector M12 (SA)

K4P2M-S-M12	2 m
K4P5M-S-M12	5 m
K4P10M-S-M12	10 m

#### cable with angular connector M12 (SA)

K4P2M-SW-M12	2 m
K4P5M-SW-M12	5 m
K4P10M-SW-M12	10 m

#### fixed connector cable (2,0 m standard, KA, KR):

additional metre of TPE-cable  
additional metre of PTFE-cable (-H)