

LVDT

Inductive Position Transducer



Series SM **Ø 12 mm**

- **ranges 2...200 mm**
- **linearity up to 0,20 %**
- **Ø 12 mm, clamp-diameter 8 mm h6**
- **output: AC, 0...10 V, 0...5 V, 4...20 mA, 0...20 mA, ±10 V, ±5 V**
- **with external or integrated cable electronics**
- **repeatability up to 1,5 µm**
- **housing nickled steel**
- **working temperature -40...+120 °C (150 °C on request)**
- **customised versions available**

TECHNICAL DATA

sensor

measurement range FS [mm]	0...2	0...5	0...10	0...25	0...50	0...100	0...200
linearity [% of FS]	0,30 % (0,20 % optional)						
types	sprung load (up to range 0...50 mm), free core, push rod guided/ unguided						
protection class	IP67, optional IP68						
vibration stability DIN IEC68T2-6	10 G						
shock stability DIN IEC68T2-27	200 G/ 2 ms						
supply voltage/ frequency	3 V _{eff} / 3 kHz						
supply frequency	2...10 kHz						
temperature range	-40...+120 °C (150 °C optional, option H, 200 °C on request)						
mounting	ø 8 mm h6 clamp diameter or ø 12 mm clamp brackets						
housing	nickled steel						
connection	cable output or M12-connector with coupling nut						
cable TPE (standard)	ø 4,5 mm, 0,14 mm ² , non-halogen, suitable for drag chains						
PTFE (option H)	ø 3,6 mm, 0,24 mm ² , max. temperature 205 °C						
max. cable length	100 m between sensor and electronics						

sprung load version (up to range 50 mm)

spring force (middle of range) [N]	0,90	0,90	0,90	0,95	0,95	-	-
max. cycles of tip at 1 mm amplitude [Hz]	55	50	50	35	20	-	-
spring stiffness [N/ mm]	0,29	0,20	0,12	0,06	0,04	-	-
life time	> 10 million cycles						

free core/ push rod/ push rod guided

max. acceleration of core/ push rod	100 G						
life time	infinite						
weight (approx., without cable) [g]	36	42	47	59	85	136	238

electronics

	IMCA external electronics (built-in)	KAB cable electronics
output signal	0...20 mA, 4...20 mA (load <500 Ohm) 0...5 V, ± 5 V (load >5 kOhm) 0...10 V, ± 10 V (load >10 kOhm)	4...20 mA (load <100 Ohm) 0...5 V, ± 5 V (load >5 kOhm) 0...10 V, ± 10 V (load >10 kOhm)
temperature coefficient	zero 150 ppm/ °C, max. value 400 ppm/ °C	460 ppm/ °C
ripple	< 0,5 mV _{eff} up to 300 Hz, < 4 mV _{eff} up to 20 MHz	< 0,5 mV _{eff} up to 300 Hz, < 4 mV _{eff} up to 20 MHz
max. frequency	300 Hz/ -3 dB (6-pole Bessel)	300 Hz/ -3 dB (6-pole Bessel)
isolation stability	> 1000 VDC	> 1000 VDC
power supply	9...36 VDC	9...36 VDC
current consumption	75 mA at 24 VDC 150 mA at 12 VDC	65 mA at 24 VDC 140 mA at 12 VDC
sensor supply	3 V _{eff} , 3 kHz (adjustable, 1-18 kHz)	3 V _{eff} , 3 kHz (adjustable, 1-18 kHz)
working temperature	-40...+85 °C	-40...+85 °C
storage temperature	-40...+85 °C	-40...+85 °C
housing	polyamide PA6.6, meets UL94-VO	aluminium
mounting	on DIN EN-rail	-

The output signal is referring to the electric measuring range. If the sensor is operated outside the measuring range or the measuring range is exceeded, the signal is also outside the defined range (i.e. > 10 V/ 20 mA or < 0 V/ 4 mA, in the graph: > 100 % or < 0 %). Please keep this in mind for control systems with cable break detection lower than 4 mA or for a maximum input voltage > 10 V of measuring instruments. If necessary install the sensor **before** connecting to the plc.

Running direction of signal: If the push rod is moving into the sensor (e.g. sprung load pushed in), the signal is reducing. If the push rod is moving out, the output signal is increasing. The running direction of the signal can also be inverted.

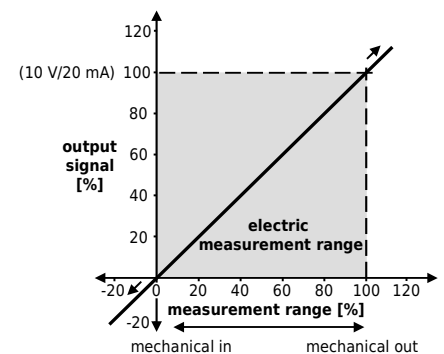

TECHNICAL DIMENSIONS

range (FS) [mm]	body length B radial cable/ connector [mm]	body length C connector M12 [mm]	core length D [mm]	push rod length E [mm]
0...2	64	67	22	54
0...5	70	73	25	60
0...10	80	83	30	70
0...25	110	113	45	100
0...50	160	163	70	150
0...100	260	263	120	250
0...200	460	463	220	450

Other measurement ranges are available on request.

type: free core, unguided push rod

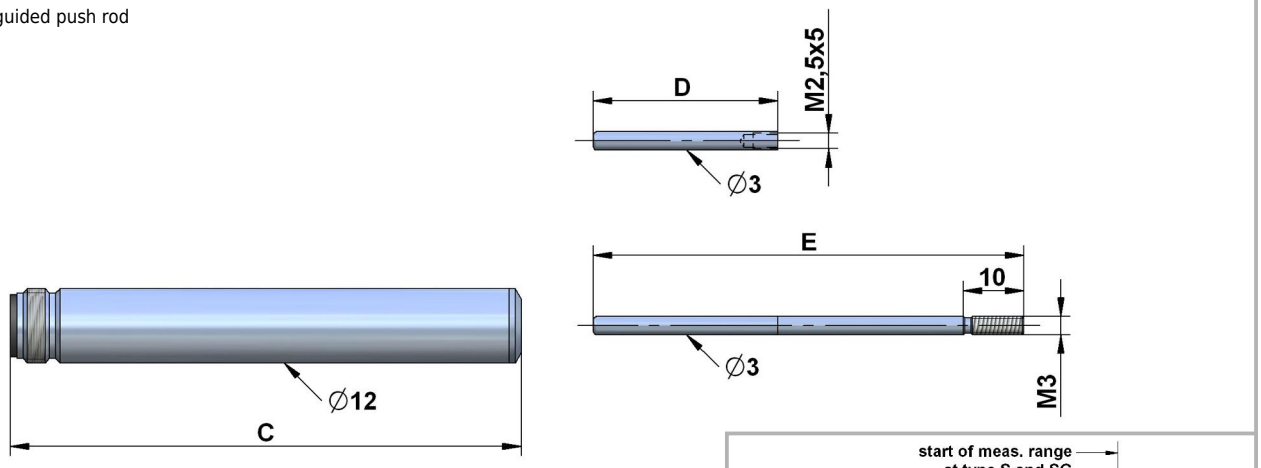

type: push rod guided

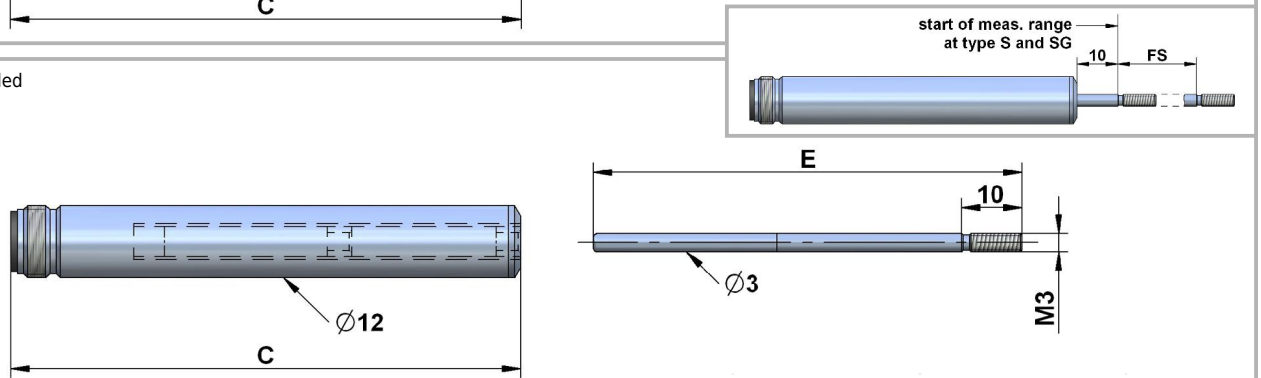

type: sprung load (up to range 0...50 mm)

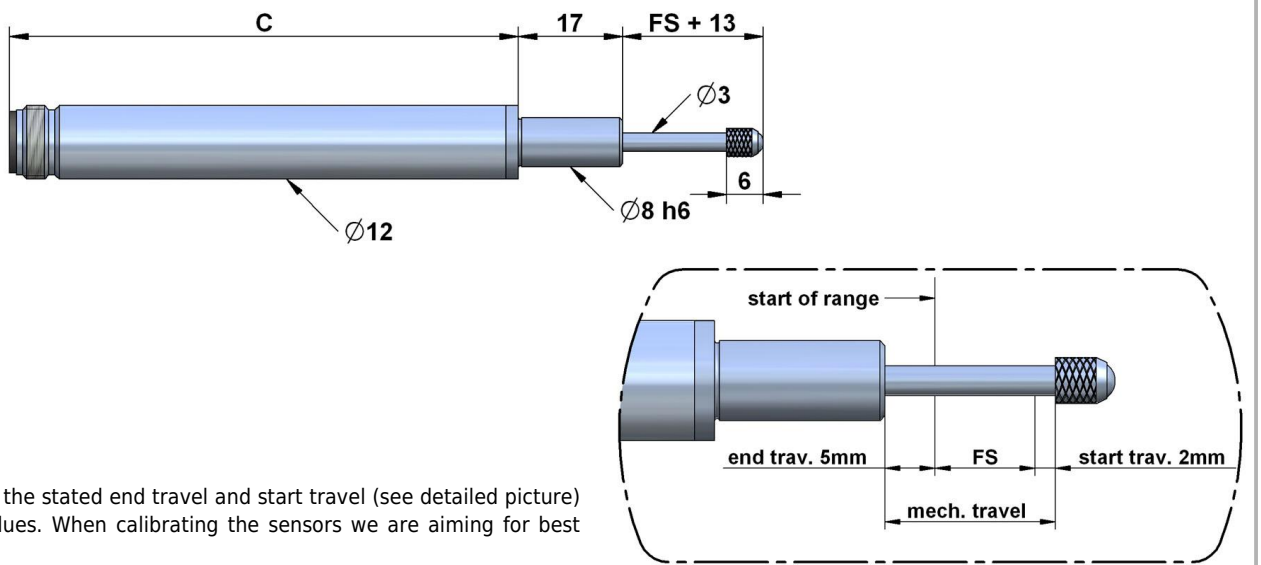

Please note that the stated end travel and start travel (see detailed picture) are standard values. When calibrating the sensors we are aiming for best linearity.

SENSOR TYPES

axial cable output

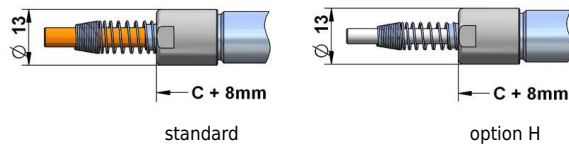

Sensors with cable output have a cable fitting and a spring for bend protection of the cable. For installation, the bending radius should not be less than 3 times the cable diameter. The standard cable length is 2 m. Instruments with option H for temperatures up to 150 °C feature a PTFE cable.

radial cable/ connector output

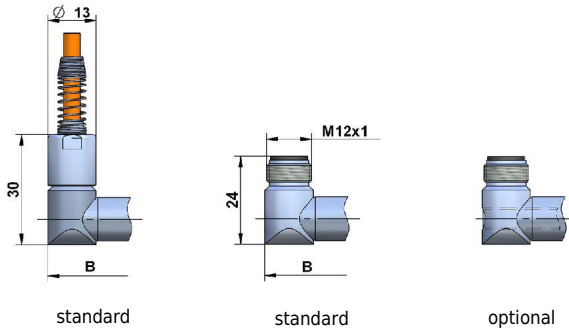

For normal application the sensors have a closed rear end body. On request sensors can be supplied with a through hole. Please use this version for applications at heavy dirt exposure. The movement of the push rod removes dirt from the sensor and conveys it to the rear. The standard cable length is 2 m.

connector output (cable with straight or angular connector)

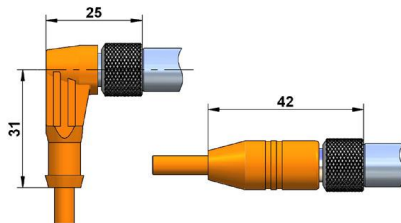

For sensors with connector output the cable has to be ordered separately. You can choose from a cable with a straight connector or with an angular connector. The connector is protected from accidental removal by a threaded fitting (M12). The cable lengths are 2/ 5/ 10 m. The connector pair has protection class IP67. The total length of the sensor with connector is:
body length of the connector M12 (see table) + 20 mm (angular connector)
body length of the connector M12 (see table) + 37 mm (straight connector)

gaiter



A gaiter is available for sprung loaded sensors to protect the mechanics from fouling. note: The measurement range of sensors with 25 mm is reduced to 20 mm! There is no gaiter available for sensors with 50 mm range.

ADJUSTMENT OF ZERO POINT AND GAIN

Please note that the zero point and gain may shift for long cable length between sensor and electronics. Thus install the sensor with the according cable length to the electronics and then adjust zero point and gain.

1. Push rod entirely in - adjust offset
Move the sensor to the zero point of the measuring range and set the offset potentiometer on 0 mA/ 0 V for the output signal.
2. Push rod entirely out - adjust gain
Move the sensor to the end of the measuring range (push rod moved out) and set the gain potentiometer on 16 mA / 10 V / 5 V for the output signal.
3. Adjust offset (4...20 mA output only).
Set the offset potentiometer on 20 mA (+4 mA) for the output signal.

Signal inversion:

If an inverted output signal is required (20...4 mA/ 10...0 V/ 5...0 V), swap clamps 6 and 8 (secondary coil) on the external electronics.

AC-OUTPUT

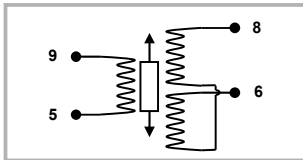

assignment for TPE-cable:

white (5): primary 2
 black (6): secondary 2
 brown (9): primary 1
 blue (8): secondary 1

assignment for PTFE-cable:

white (5): primary 2
 green (6): secondary 2
 yellow (9): primary 1
 brown (8): secondary 1

assignment M12-connector:

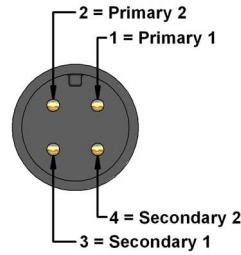

CABLE ELECTRONICS KAB

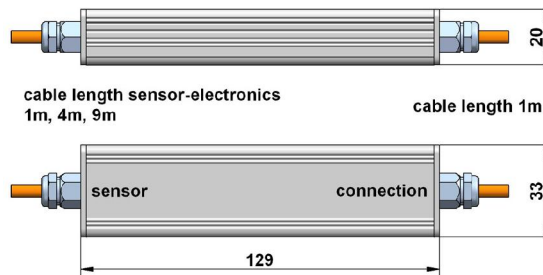

assignment for TPE-cable:

brown: supply V+
 blue: GND
 black: output GND
 white: output signal

assignment for PTFE-cable:

yellow: supply V+
 brown: GND
 green: output GND
 white: output signal

If not specified otherwise the cable electronics is placed at 1 m from the end of the cable. On request in your order, however, the cable electronics can be placed at any position.

EXTERNAL ELECTRONICS IMCA



external electronics IMCA
 (for DIN-rail mounting)

dimensions:

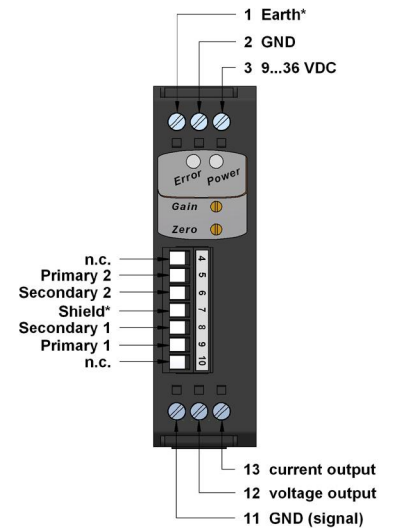
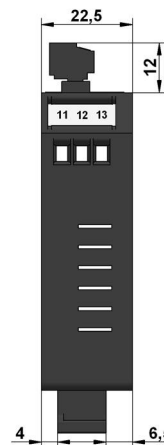
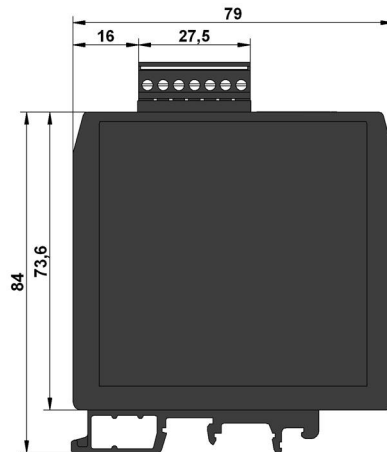

Connection

The external electronics IMCA is designed to be installed in switch cabinets (Din-rail mounting). The connection to the sensor is conducted as connector with screw terminals.

* Terminals 1 and 7 are internally connected.

At harsh EMC environments, it is possible to install the electronics at a max. distance of 100 m in a switch cabinet. A twin twisted pair cable (4-cores, minimum cross section 0,5 mm²), single or double shielded, is to be used for the further wiring to connect the external electronics to the system. It is recommended to ground the shield in the switch cabinet near the electronics (do not ground at the machine/ sensor). The sensor housing is grounded at the machine frame. To prevent interference, the cable length should not exceed 100 m.

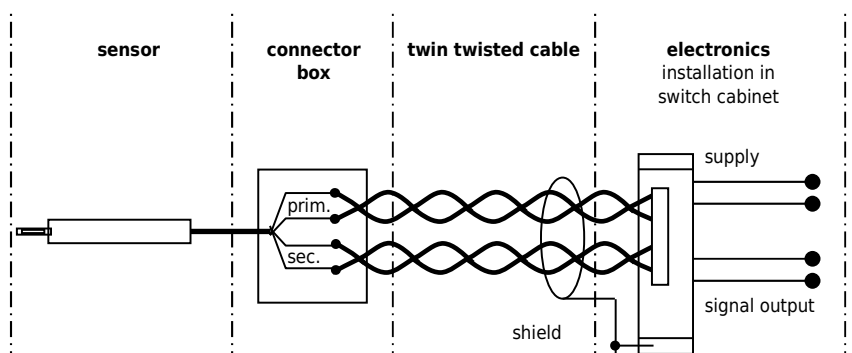

ORDER CODE

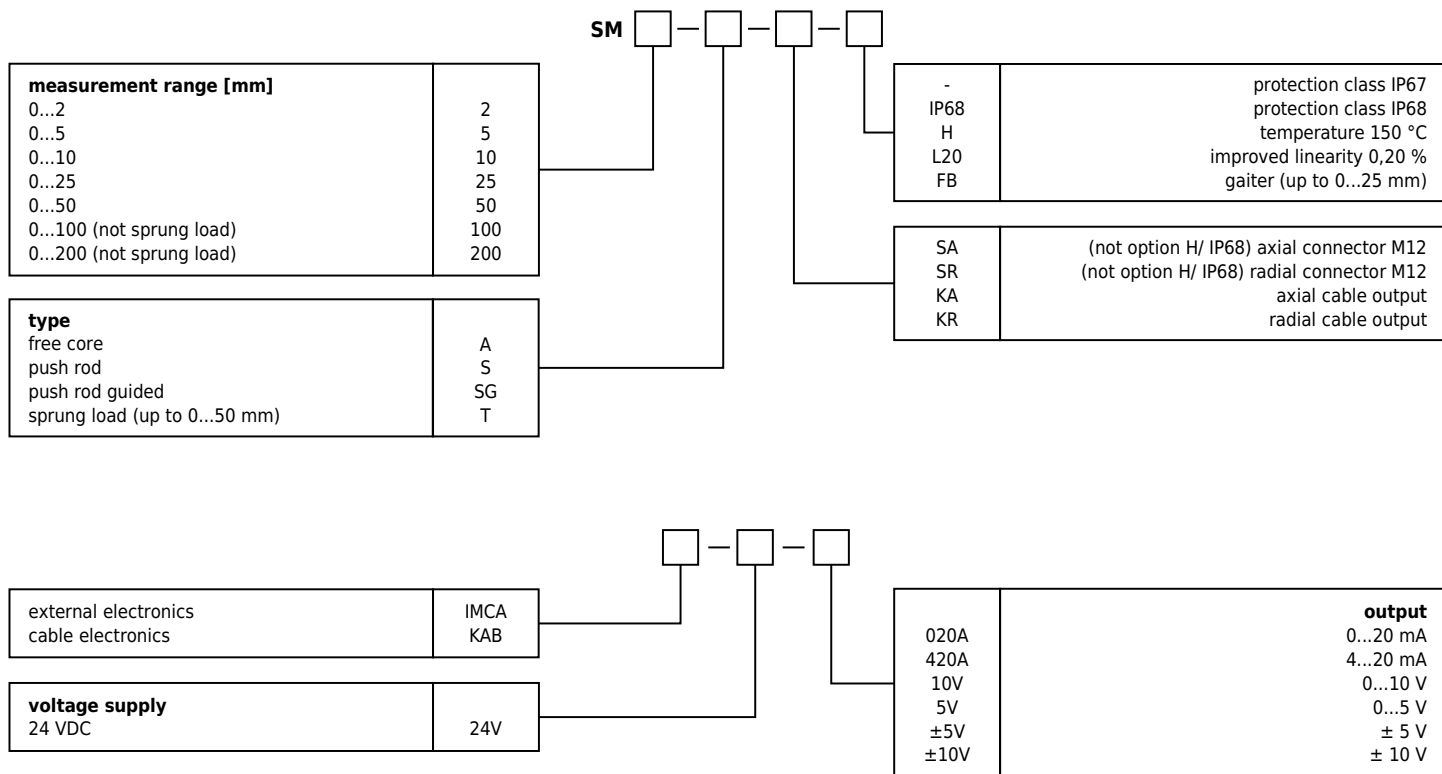

Connector cable:

cable with straight connector M12 (SA)

K4P2M-S-M12	2 m
K4P5M-S-M12	5 m
K4P10M-S-M12	10 m

cable with angular connector M12 (SA)

K4P2M-SW-M12	2 m
K4P5M-SW-M12	5 m
K4P10M-SW-M12	10 m

fixed connector cable (2,0 m standard, KA, KR):

additional metre of TPE-cable
 additional metre of PTFE-cable (-H)