

DRAWWIRE SENSOR

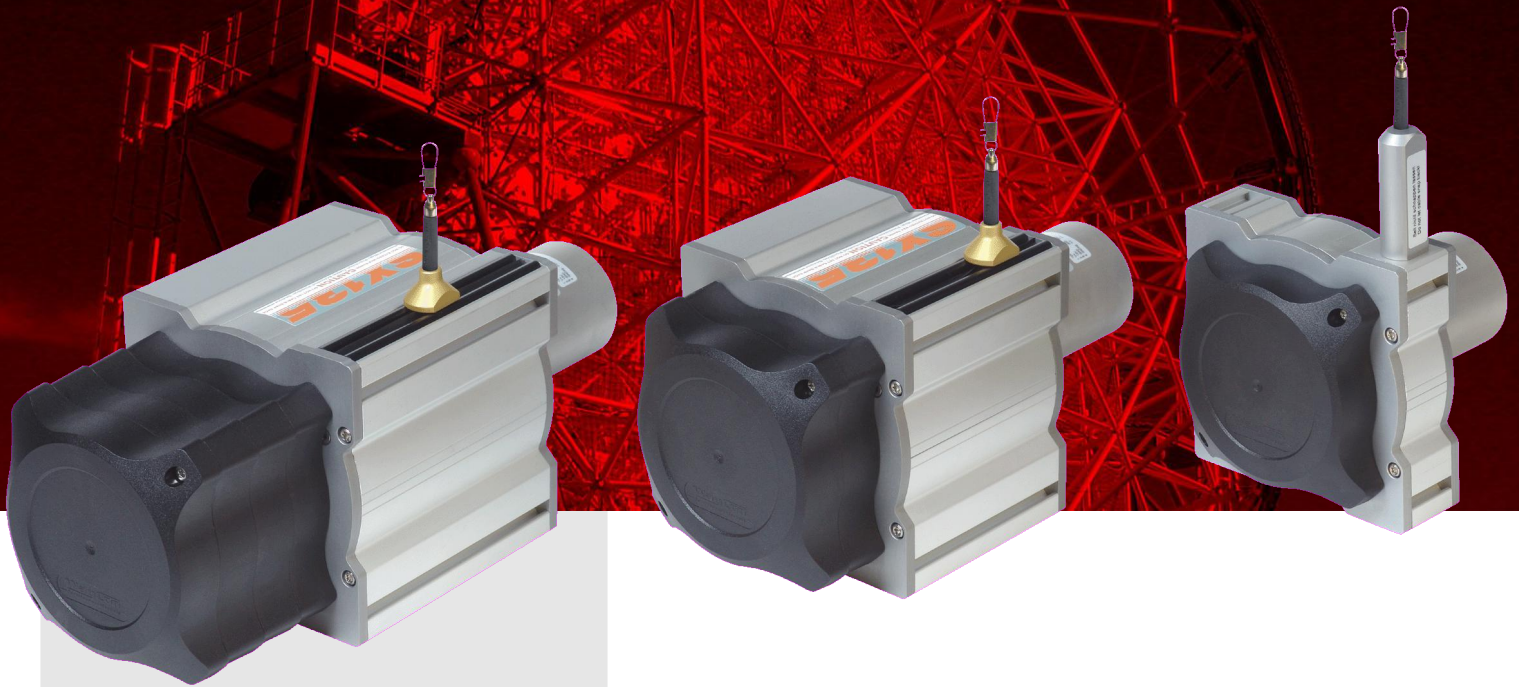

Content:

Introduction - Applications2
Options3
Technical data4
Technical drawings5
Mounting / easy-clamp9
Analog output	..10
Digital output incremental	..11
Digital output absolute	..12
Accessories	..13
Installation - warning notices	..14
Order code	..15

SX135 Long Range

Key-Features:

- Ranges 8000...42.500 mm
- Analog - Digital Incremental - Digital Absolute
- Linearity up to ± 0.02 % of FS
- Protection class up to IP67
- High dynamics
- High EMC-grade
- Customised versions available

INTRODUCTION

WayCon Positionsmesstechnik GmbH is a manufacturer of high quality draw wire position transducers for industrial use. Due to its small overall size, its short assembly time and its possible customisation, the SX sensor technology is a cost-effective and flexible solution for a wide range of industrial applications. The dynamics of the draw wire transducer allows a high motion speed and acceleration of the measuring target. Its rugged design and high quality makes applications in harsh industrial environments possible. Special instruments are available with mounting service of encoder on site, as well as customised versions of housing.

Sensor principle:

A constant spring force coils the measuring rope accurately, single-layered on an ultralight rope capstan, so that its linear motion is converted into rotation. The sensor element (encoder) provides the output signal required.

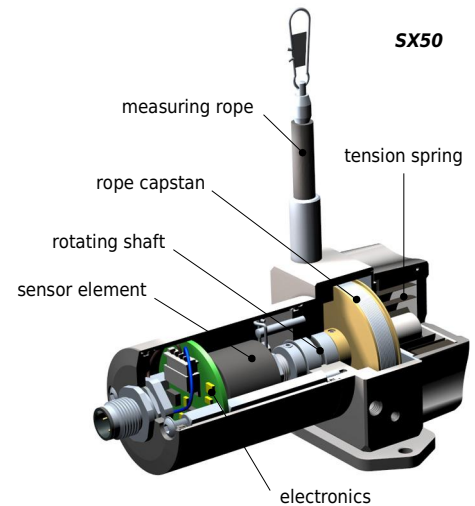

OUTLINE

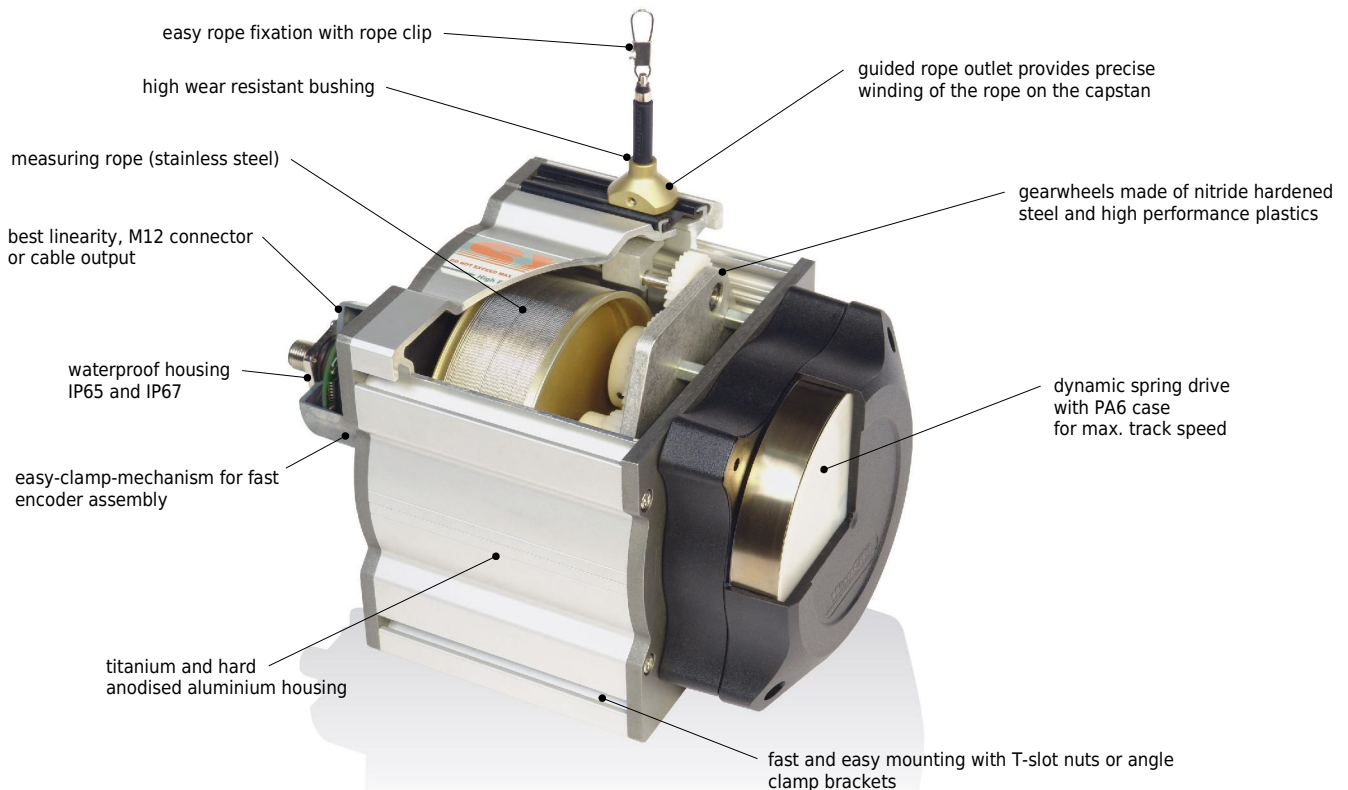

APPLICATIONS

- lifting tables and platforms
- positioning of fork-lifts
- level control system
- portal frames and gantry cranes
- lifting and rescue technology
- hydraulic cylinder
- property management
- linear guides
- x-y-axis positioning
- pipe displacement

OPTIONS

SSB8 / SSB10 / IP67 / CO / ICP / TEMP-40

SSB8 (up to range 8 m) / SSB10 (range 10-42.5 m): All ball bearings are made of stainless steel. This option is suitable for applications in humid or moderate corrosive environmental conditions.

IP67: Use option IP67, if sensor is fully immersed in water (temporarily). Like option SSB8, only stainless steel ball bearings are mounted. Note that with this option there may occur a light hysteresis in the output signal due to the special sealing. The max. acceleration is reduced to 60 % of the specified value.

CO: By the use of a special technology all components of the housing and the inner mechanics become HARTCOAT® coated. This coating is a hartanodic oxidation that protects the sensor from corrosion by aggressive media (e. g. sea water) with a hard ceramics-like layer. This option includes SSB8.

ICP: This version combines the options CO (HARTCOAT®-coating) and IP67 (protection class IP67). In addition, a increased corrosive protection is achieved by the use of special components.

TEMP-40: The use of special components enhances the operating temperature to -40...+85 °C.

IN

The analog signal of the sensor is increasing by extracting the rope (standard). Option IN inverts the signal, i. e. the signal of the sensor declines by extracting the rope.

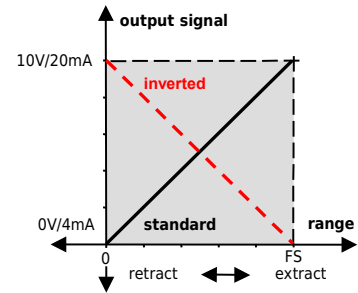

L05 / L02

Improved linearity on 0.05% of measuring range. Resolution, repeatability and sensibility remain unchanged.

Improved linearity on 0.02% of measuring range. Resolution, repeatability and sensibility remain unchanged. This option is only available for incremental sensors.

K1 / K2 / K3

Optional cable/ connector orientation for sensors with digital output/ encoder.

range: 8 m

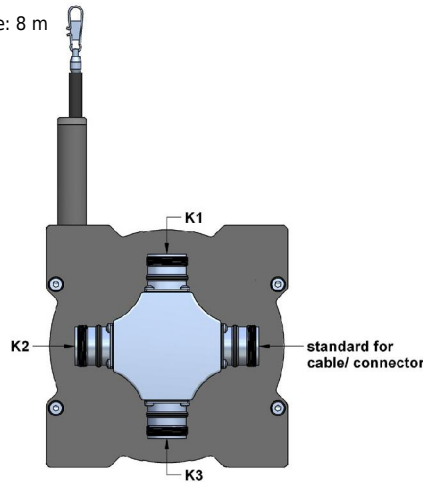

range: 10...42.5 m

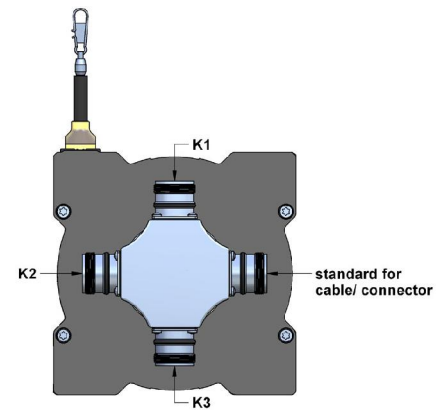

M4 rope fixation

Optional, pivoted rope fixation with screw thread M4, length 22 mm. Ideal for attachment to through holes or thread holes M4.

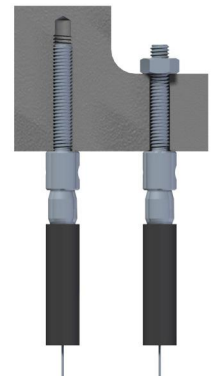

SERIES SX135

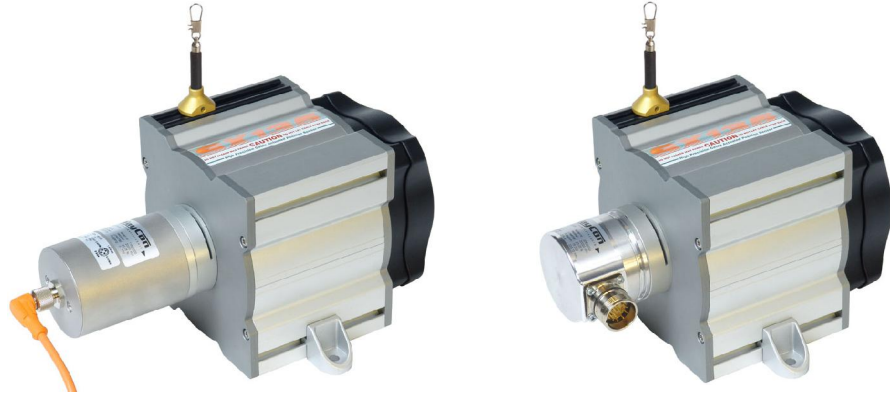

output	analog output potentiometer/ 0...10 V/ 4...20 mA (page 10)	digital output incremental A/B-pulse, 90° phase-delayed (page 11)
sensor element	hybrid potentiometer	incremental encoder/ optical code disc
connection	M12-connector or cable output 2 m	connector or cable output 2 m
protection class	IP65, optional IP67	IP65, optional IP67
humidity	max. 90 % relative, no condensation	max. 90 % relative, no condensation
temperature	-20...+85 °C	-20...+85 °C
weight	approx. 4200 g	approx. 4200 g
housing	aluminium, titanium-grey anodised, spring case PA6	aluminium, titanium-grey anodised, spring case PA6

Technical data - analog output

ranges [m] *	8	10	12	15	20	25	30	35	40	42.5
linearity [%]	0.1	0.1	0.1	0.1	0.1	0.1	0.1	0.1	0.1	0.1
linearity optional [%]	0.05	0.05	0.05	0.05	0.05	0.05	0.05	0.05	0.05	0.05

Technical data - digital output incremental

ranges [mm] *	8	10	12	15	20	25	30	35	40	42.5
linearity [%]	0.05, independent of measurement range									
linearity optional [%]	0.02, independent of measurement range									
available resolution, range 8 m [pulses/ mm]	0.28	1.4	2.8	5.6	14					
available resolution, range 10 - 42.5 m [pulses/ mm]	0.3	1.5	3	6	15					
Z-pulse-distance, range 8 m [mm]	357.14									
Z-pulse-distance, range 10 - 42.5 m [mm]	333.33									

* other measurement ranges on request

Mechanical data

range [m]	rope tension		velocity	acceleration*
	F_{min} [N]	F_{max} [N]	V_{max} [m/s]	a_{max} [m/s ²]
8	7.2	10.4	10.0	140
10 / 12	4.8	7.2	6.0	80
15	6.8	11.2	6.0	80
20	6.4	9.2	5.0	60
25	7.8	11.4	5.0	60
30	6.4	9.6	5.0	60
35	7.4	11.6	5.0	60
40 / 42.5	5.4	9.0	5.0	60

* reduced to 60 % with option IP67

TECHNICAL DRAWING

8 m range, analog output

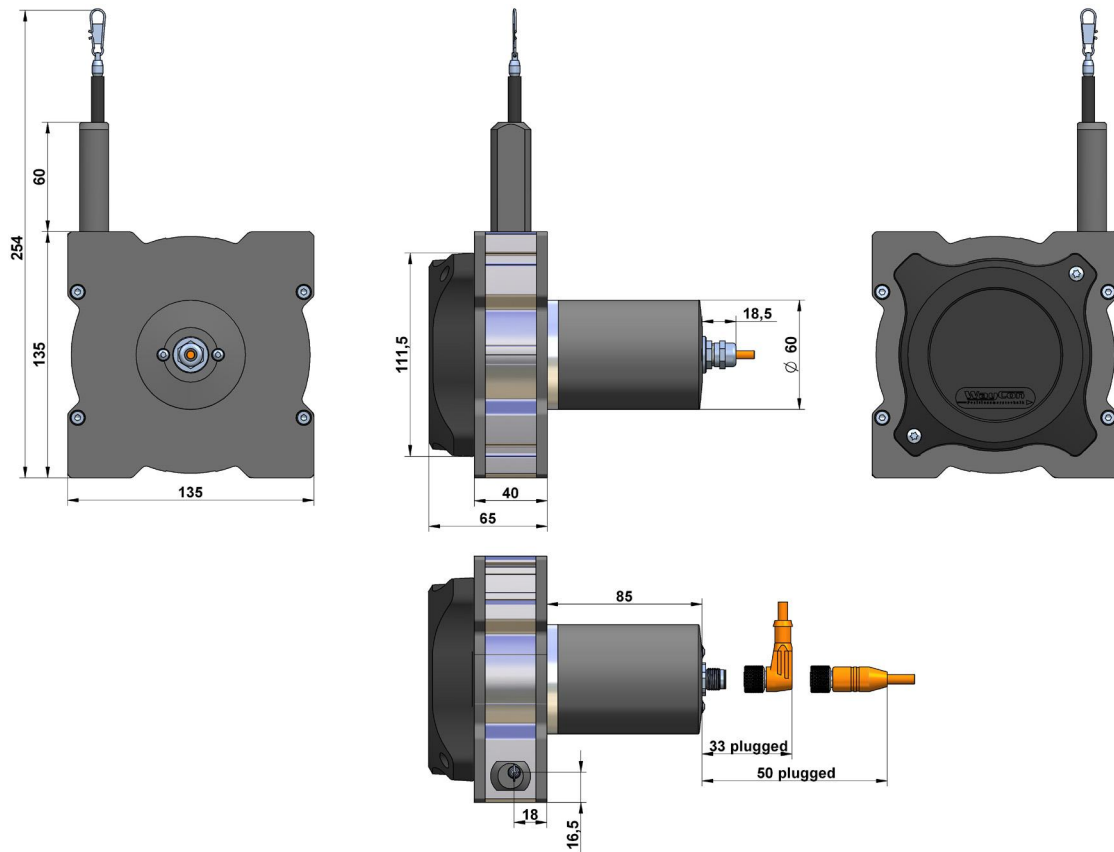

8 m range, digital output incremental

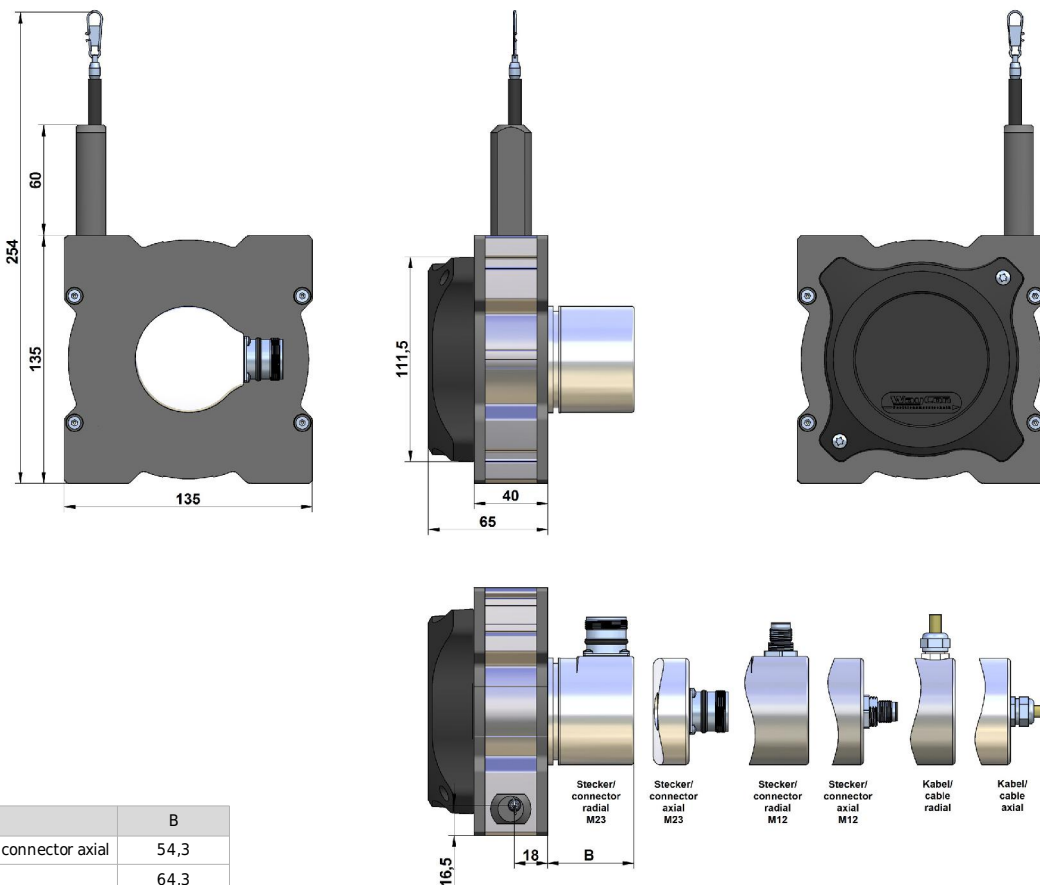

output	B
cable axial/ radial, connector axial	54,3
connector radial	64,3

TECHNICAL DRAWING

10 - 12 m range

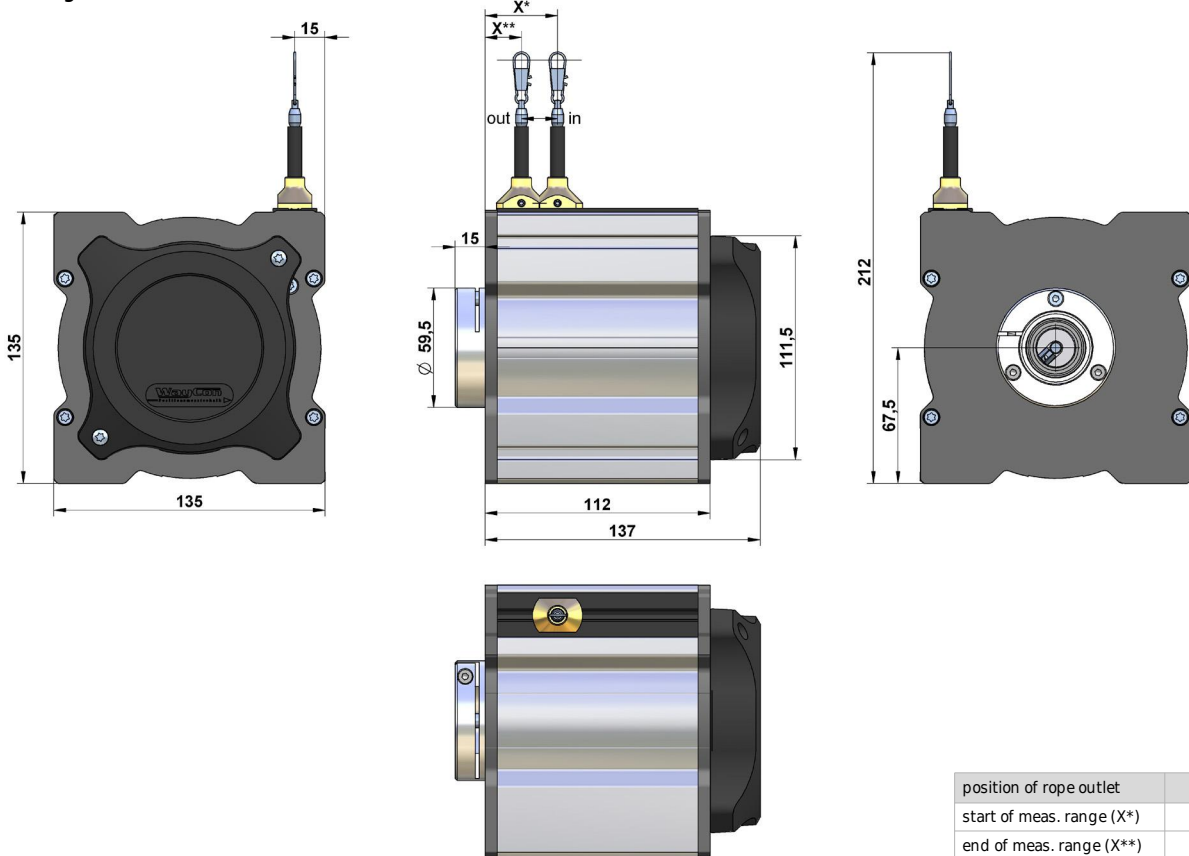

15 - 20 m range

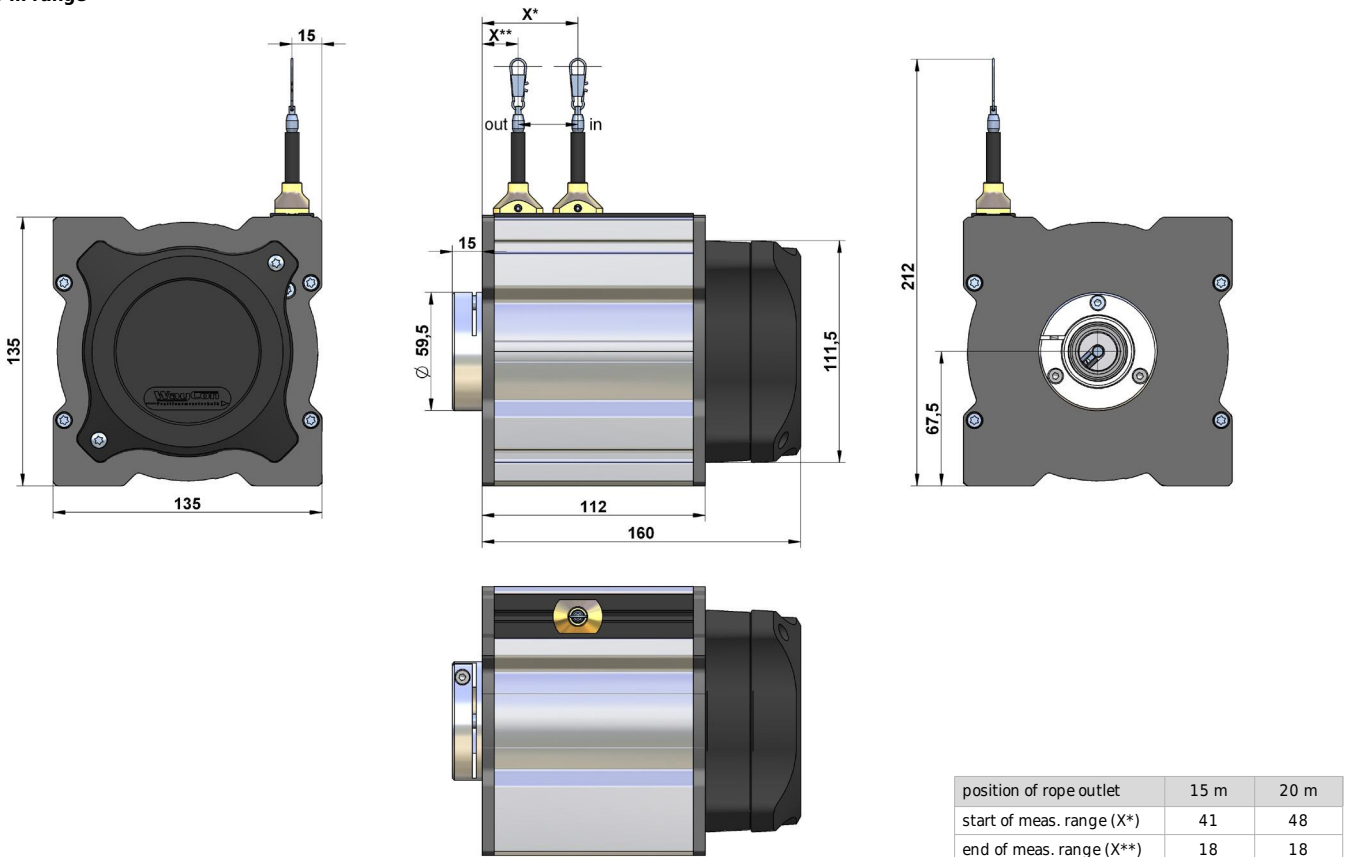

TECHNICAL DRAWING

25 - 30 m range

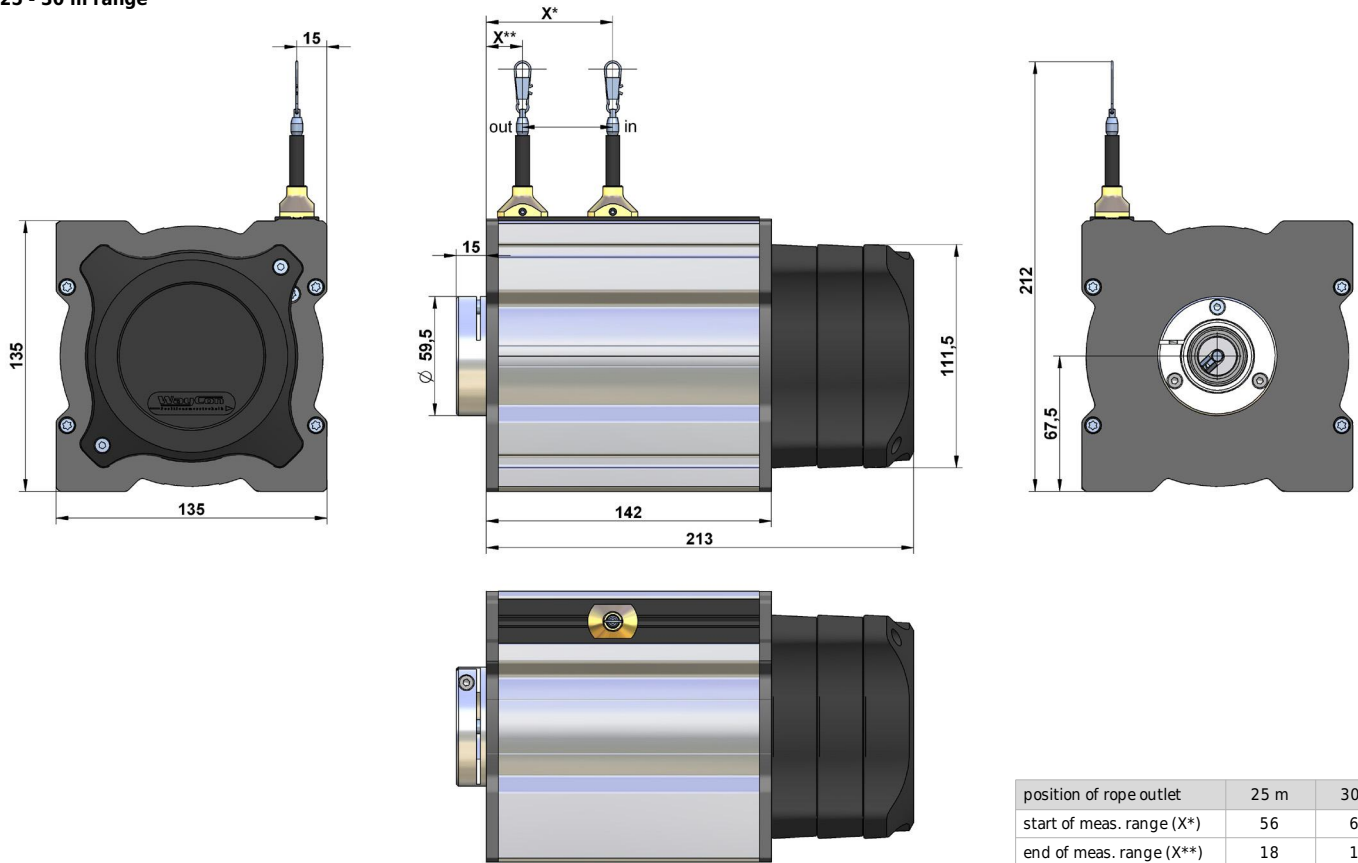

35 - 42.5 m range

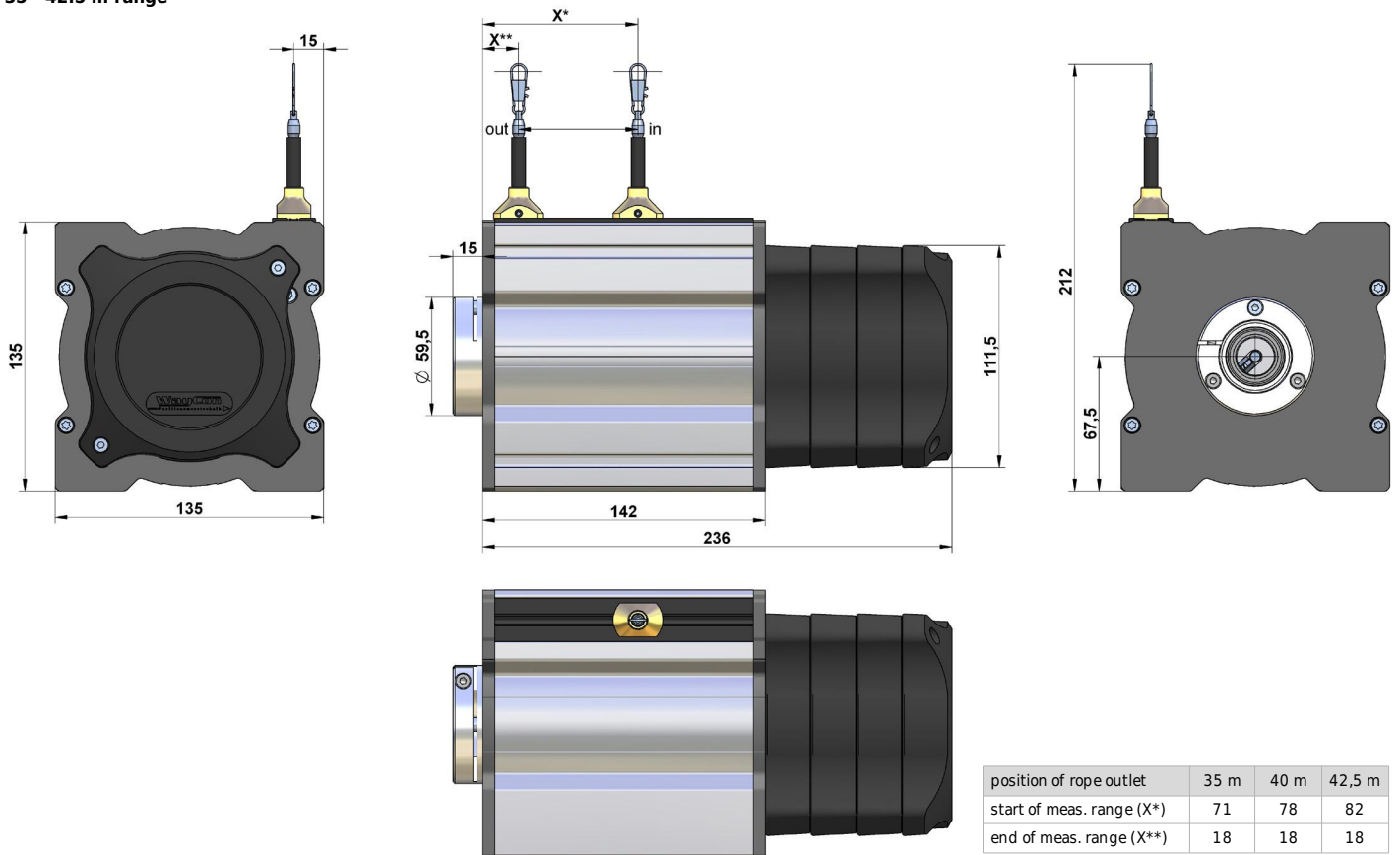

TECHNICAL DRAWING

dimensions for analog output

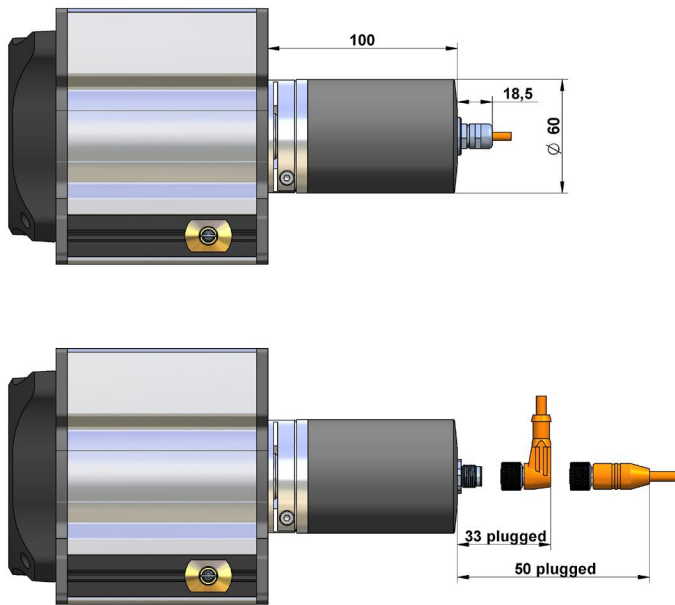

dimensions for digital output incremental

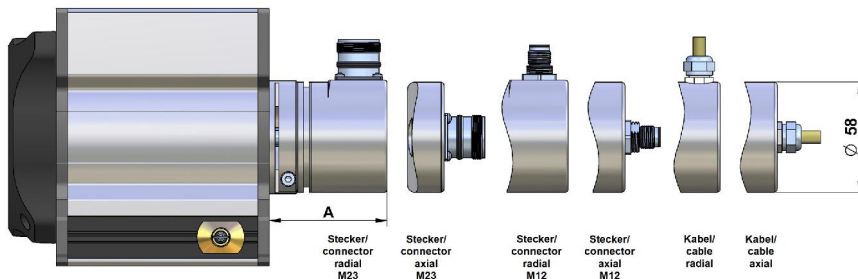

output	A
cable axial/ radial, connector axial	54,3
connector radial	64,3

MOUNTING OPTIONS

1. by using the grooves in the sensor housing

The included T-slot nuts can be easily inserted into grooves of the sensor housing. The nuts have a metric thread M6.

Each sensor up to 20 m measurement range comes with 2 nuts, from 20 to 42.5 m for nuts are included.

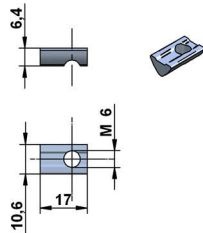

2. by angle clamp brackets

The angle clamp brackets feature a bore for M6 screw to fix it on a plate/slab or a profile.

Each sensor up to 20 m measurement range comes with 2 brackets, from 20 to 42.5 m for brackets are included.

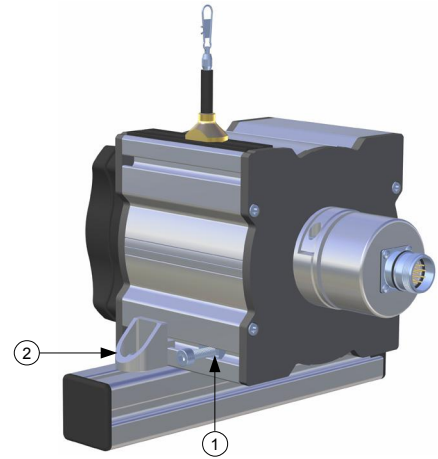
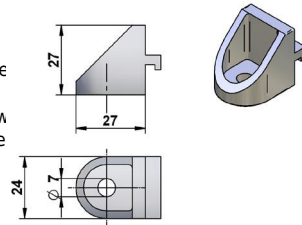

Important: The grooves of the sensor housing, the nuts and brackets are compatible to the aluminium building kit system from *item Industrietechnik GmbH* (www.item.info).

Position of the grooves:

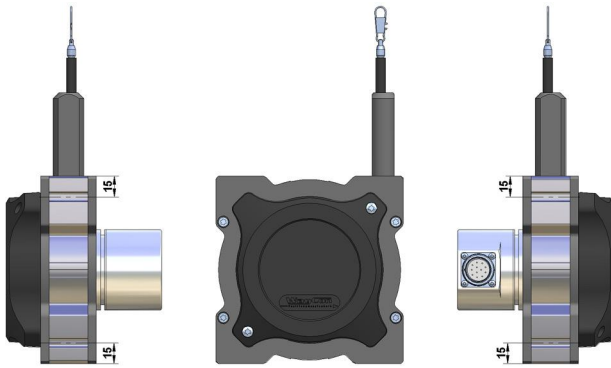

Mounting by using brackets:

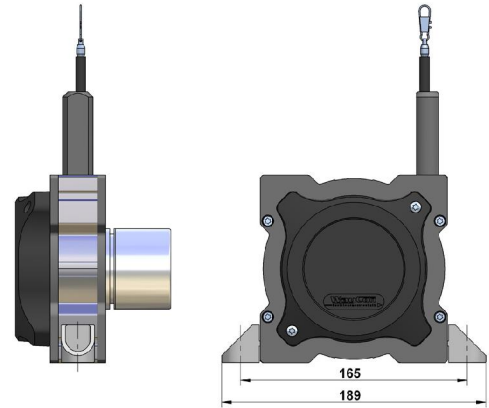

ENCODER ASSEMBLY BY EASY-CLAMP-MECHANISM

IMPORTANT: All incremental and absolute encoders must have a clamping flange (diameter 36 mm), a shaft diameter of 10 mm and a shaft length of 10-20 mm.

1.

Please mount the included coupling (1) on the shaft of the encoder and fix the set screw. Therefore you will need a hexagon screwdriver, size 2. Be careful that the dimension between contact surface of the encoder and the end of the cylinder bolt is 35 mm.

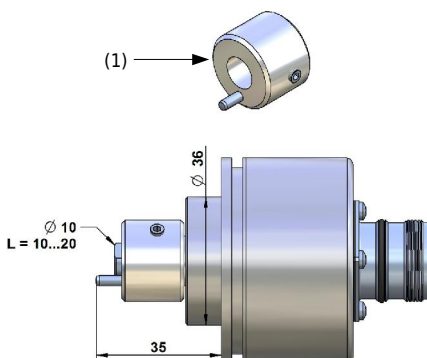

2.

Please mount the encoder into the easy-clamp-flange. The cylinder bolt must slip into the spring (2).

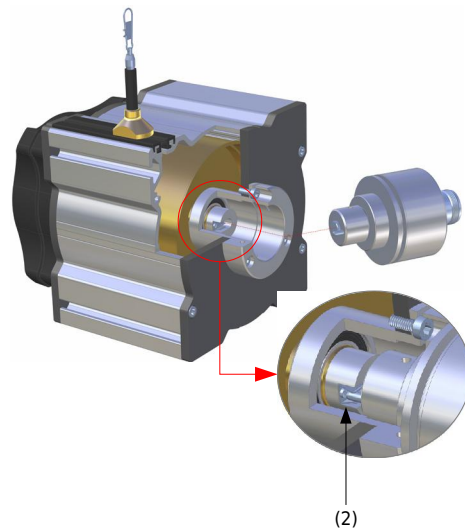

3.

By tightening the radial screw the encoder will be clamped and secured from twisting. Please use a hexagon screwdriver, size 3.

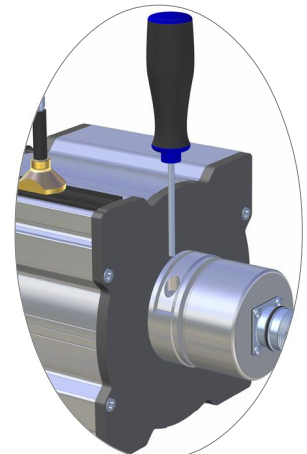

ANALOG OUTPUT

Potentiometer (voltage divider)

output	1 kOhm
supply voltage	max. 30 V
recommended cursor current	< 1 μ A
noise	depending on supply
working temperature	-20...+85 °C
temperature coefficient	\pm 0.0025 %/K

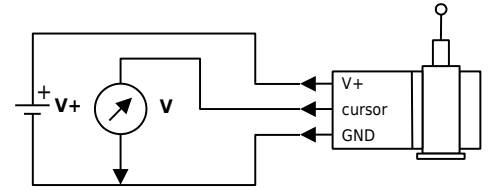

0...10 V voltage output

output	0...10 V, galvanically isolated, 4 conductors
supply voltage	12...30 VDC
max. current consumption	22.5 mA (unloaded)
output current	max. 10 mA, min. load 10 kOhm
dynamics	< 3 ms from 0...100 % and 100...0 %
noise	3 mV _{pp} typically, max. 37 mV _{pp}
inverse-polarity protection	yes, infinite
short-circuit proof	yes, permanent
working temperature	-20...+85 °C
temperature coefficient	0.0037 %/K
electromagnetic compatibility (EMC)	according to EN 61326-1:2006

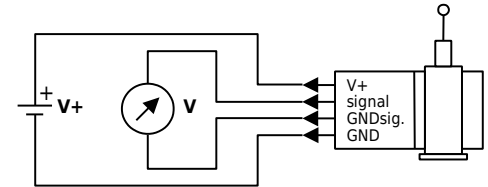

note: GNDsignal and GND may be connected in 3-wire system.

4...20 mA current output

output	4...20 mA, 2 conductors
voltage supply	12...30 VDC
output current	max. 50 mA in case of error
dynamics	< 1 ms from 0...100 % and 100...0 %
noise	0.03 mA _{pp} = 6 mV _{pp} at 200 Ohm
inverse-polarity protection	yes, infinite
working temperature	-20...+85 °C
temperature coefficient	0.0079 %/K
electromagnetic compatibility (EMC)	according to EN 61326-1:2006

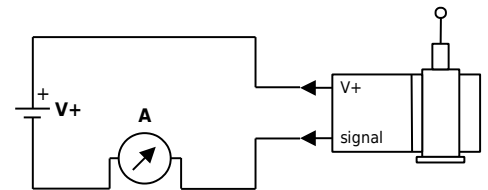

CONNECTION

cable output:

axial 2.0 meter standard, other cable lengths optional
 type: TPE, flexible
 diameter: \varnothing 4.5 mm
 stranded wire: 0.25 mm²
 temperature range: fixed installation -30...+85 °C, flexible installation -20...+85 °C

pin	wire colour	10 V	420 mA	1 kOhm
1	brown	V +	V +	V +
2	white	signal	n. c.	cursor
3	blue	GND	signal	GND
4	black	GND signal	n. c.	n. c.

4-pin M12 connector output (socket):

profile/ view on solder side of mating connector

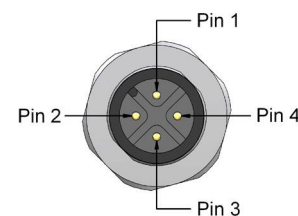

DIGITAL OUTPUT INCREMENTAL

Electrical data	Linedriver L	Push Pull G
	RS422 (TTL-compatible)	
supply voltage	5 VDC, $\pm 5\%$	8...30 VDC
current consumption (no load)	typical 70 mA, max. 100 mA	typical 80 mA, max. 150 mA
max. load/ channel	± 20 mA	± 30 mA
max. pulse frequency	300 kHz	300 kHz
min. signal level high	2.5 V	$U_B - 3$ V
max. signal level low	0.5 V	2.5 V
recommended circuit		

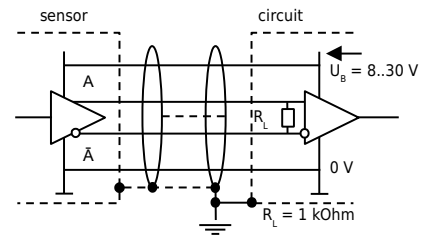
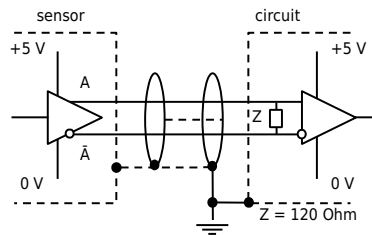

connection	connector 12-pin (counterclockwise), cable output 2 m	connector 12-pin (counterclockwise), cable output 2 m
protection class	IP65, optional IP67	IP65, optional IP67
max. cable length	up to 1000 m	up to 250 m

output signal

Pulses A and B are 90° phase-delayed (detection of direction). The Z-signal recurs with pulse distance Z and may be used as point of reference.

Diagram shows the signal without inverted signals; time-line for return of rope.

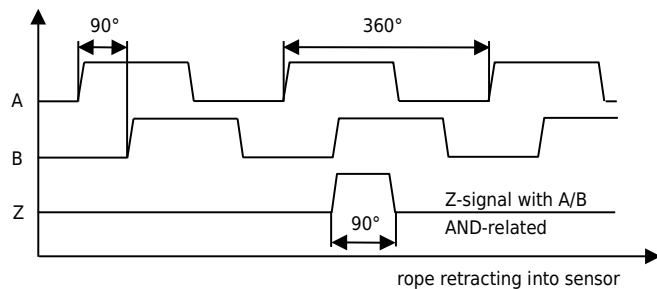

CONNECTION

Assignment

signal	0 V	U_B+	$0 V_{sens}^*$	$U_{Bsens}+^*$	A	A -	B	B -	Z	Z -	screen
12-pin connector	10	12	11	2	5	6	8	1	3	4	housing
8-pin connector	1	2	-	-	3	4	5	6	7	8	housing
wire colours	white	brown	black	violet	green	yellow	grey	pink	blue	red	housing

* For Linedriver L only. For long cable lengths it may occur that the operating voltage at the sensor does not suffice due to the output resistance. With the sensor lines $0V_{sens}$ and $+U_{Bsens}$ the operating voltage can be checked and, if necessary, be readjusted at the input connection.

12-pin connector output (socket)

Profile/ view on solder side of mating connector

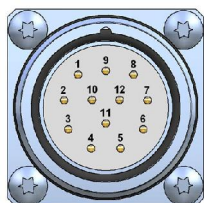

8-pin connector output (socket)

Profile/ view on solder side of mating connector

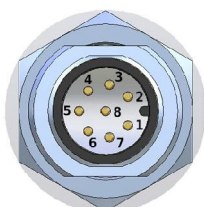

cable output

radial/ axial 2 metre standard

other cable length optional

type: UL2464/ 1061, LiYY, flexible

outer diameter: $\varnothing 6,5$ mm

stranded wire: $10 \times 0,25$ mm²

temperature range: fixed installation -30...+80 °C,

flexible installation -20...+80 °C

DIGITAL OUTPUT ABSOLUTE

output	Profibus-DP	CANopen	DeviceNet	EtherCAT	SSI	Profinet
scalable resolution	yes	yes	yes	yes	no	yes
standard resolution at range 8 m [pulses/ mm]	22.94	22.94	22.94	22.94	22.94	22.94
max. resolution at range 8 m [pulses/ mm]	183.50	183.50	22.94	183.50	-	183.5
standard resolution at range 10 - 42.5 m [pulses/ mm]	24.58	24.58	22.94	24.58	24.58	24.58
max. resolution at range 10 - 42.5 m [pulses/ mm]	196.61	196.61	22.94	196.61	-	196.61
supply voltage	10...30 VDC	10...30 VDC	10...30 VDC	10...30 VDC	10...30 VDC	10...30 VDC
current consumption (no load, at 24 VDC)	90 mA	65 mA	max. 290	90 mA	25 mA	200 mA
protection class	IP65	IP65	IP65	IP65	IP65	IP65
protection class optional	IP67	IP67	-	IP67	IP67	IP67
working temperature	-20...+80 °C	-20...+80 °C	-20...+80 °C	-20...+80 °C	-20...+80 °C	-20...+80 °C

Other encoder types (supply voltage, resolution, cable/ connector output) are available on request.

TECHNICAL DRAWING

Note: The dimensions of the sensor housings are given on pages 5 to 8.

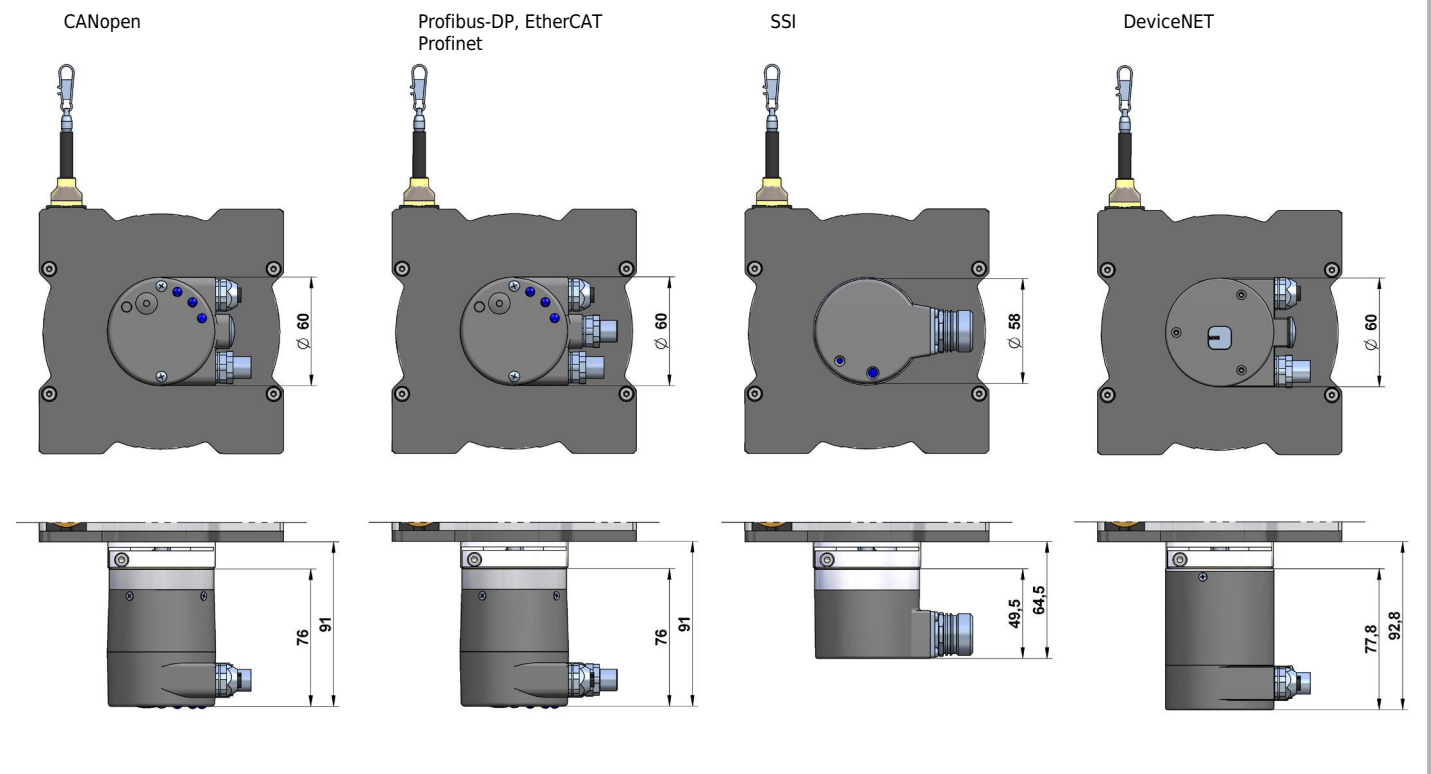

CONNECTION

encoder type

Profibus-DP	bus terminal cover, 3 x M12-connector (2 x male, 1 x female)
CANopen	removable bus terminal cover, 2 x M12-connector (1 x male, 1 x female)
DeviceNET	bus terminal cover, 2 x M12-connector (1 x male, 1 x female)
EtherCAT, Profinet	bus terminal cover, 3 x M12-connector (1 x male, 2 x female)
SSI	12-pin M23-connector (pins counter clockwise), mating connector CON012-S

For further information and electrical connection please see Sendix Absolute Encoder data sheet

ACCESSORIES

Cable with mating connector M12, shielded

K4P: 4-pole for analog output: Poti/ 10V/ 420A

K8P: 8-pole for digital output incremental

cable with straight connector:

K4P2M-S-M12 / K8P2M-S-M12	2 m
K4P5M-S-M12 / K8P5M-S-M12	5 m
K4P10M-S-M12 / K8P10M-S-M12	10 m

cable with angular connector:

K4P2M-SW-M12 / K8P2M-SW-M12	2 m
K4P5M-SW-M12 / K8P5M-SW-M12	5 m
K4P10M-SW-M12 / K8P10M-SW-M12	10 m



Mating connector M12, shielded, for self assembly

D4: 4-pole for analog output: Poti/ 10V/ 420A

D8: 8-pole for digital output incremental

straight connector: D4-G-M12-S / D8-G-M12-S
angular connector: D4-W-M12-S / D8-W-M12-S

protection class: IP67
temperature range: -25...+90 °C
mode of connection: spring cage

cable passage: \varnothing 4...8 mm
wire cross-section: 0.14...0.34 mm²
good chemical and oil resistance



Cable with mating connector M23, for digital output incremental and SSI, shielded

Incremental:		SSI:	
K8P2M-S-M23	2 m	K12P02M-S-M23-SSI	2 m
K8P5M-S-M23	5 m	K12P05M-S-M23-SSI	5 m
K8P10M-S-M23	10 m	K12P10M-S-M23-SSI	10 m
		K12P15M-S-M23-SSI	15 m

Mating connector CON012-S for digital output incremental and SSI, shielded

M23, straight, female connector, 12-pin, metal housing

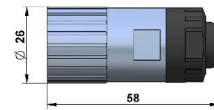

Cable with mating connector M12 for digital output CANopen and Profibus, shielded

CANopen:		Profibus:	
K5P2M-B-M12-CAN	2 m, female connector	K5P2M-B-M12-PROF	2 m, female connector
K5P2M-S-M12-CAN	2 m, male connector	K5P2M-S-M12-PROF	2 m, male connector
K5P2M-SB-M12-CAN	2 m, female - male	K5P2M-SB-M12-PROF	2 m, female - male
		M12-PROF-AW	terminating resistor



Deflection pulley - UR2

By using the deflection pulley, the rope can be looped around to e. g. measure in places that are difficult to access or to protect the sensor from inclined traction on the rope. Several pulleys may be used.

material: anodised aluminium, POM
mounting: by 2 hexagon socket or countersunk screws M6,
vertical or horizontal mounting possible.

Ball bearings with special low temperature grease and RS-sealing.

Temperature range: -40...+80 °C.

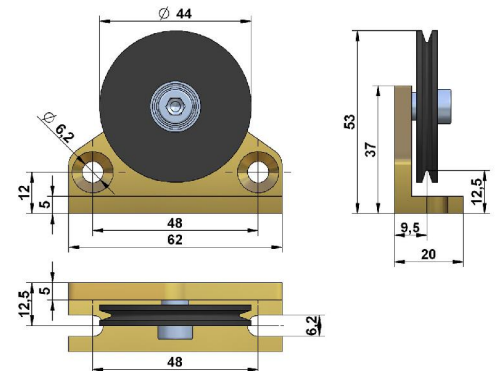
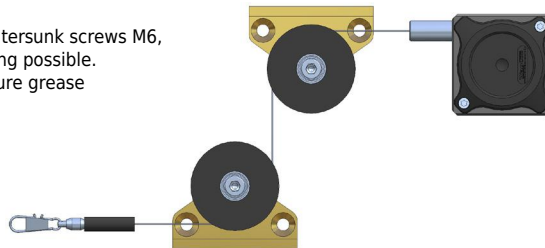

Rope extension - SV

For bridging a greater distance from the measuring target to the sensor a rope extension can be applied. The rope clip must not be guided over the deflection pulley.

Please specify the length needed in your order. The minimum length is 150 mm.

SV1-XXXX: rope extension (150...4995 mm)
SV2-XXXX: rope extension (5000...19.995 mm)
SV3-XXXX: rope extension (20.000...40.000 mm)

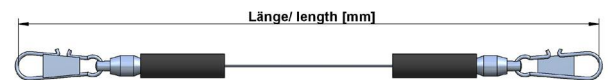

Magnetic clamp - MGG1

Use the magnetic clamp to quickly attach the rope to metallic objects without any assembly time. A rubber coating provides gentle contact (e. g. on varnished surfaces) and prevents from slipping due to vibration. The magnet consists of a neodym core for an increased adhesive force of 260 N. The hook makes it easy to attach the rope clip (drill protection).

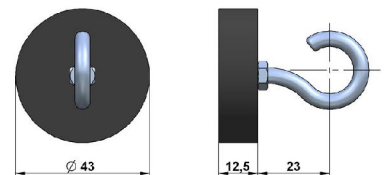

Other cable length are available on request.

ACCESSORIES

Digital distance and speed measurement - PAX

Use PAX display to visualise the covered distance or the speed (tachometer sensor) of the position transducer. It enables a transmission of the measurement data to the computer via interface. The comparator allows a good-bad-evaluation (limit values function).

inputs:	incremental/ analog, 2 independent counter, 1 tachometer sensor
analogue output:	0...20 mA, 4...20 mA, 0...10 V (plug in card)
serial interfaces:	RS485, RS232, DeviceNet, USB, Profibus (plug in cards)
Protection class (front panel):	IP65
display:	6 digits
power supply:	11...36 VDC or 85...250 VAC

For further information please see the data sheets of the PAX display series.



INSTALLATION

- Mount the sensor at the designated place by using the fixing holes **before** extracting the rope and **before** attaching the rope to the measuring target.
- Open the rope clip (not with set screw M4) after the sensor is fully mounted and extract the measuring rope. Hook the rope clip on the measuring object and close the bracket of the clip. For your safety put a screw driver trough the clip to extract the rope.
- Check the track of the measuring target on **collision** with the sensor housing and on **exceeding** the specified measurement range. When installing the sensor make sure that the rubber stopper does not touch the rope outlet.
- Connect the electronics according to the sensor type. When laying the cables be careful not to under-run the minimal allowed bending radius of the cable (5 x cable diameter).
- The rope must be extracted from the sensor **vertically**. The maximum variation from the vertical is 3°. Avoid carefully extracting the rope at an inclination, since the durability of the instrument would shorten considerably. If it is not possible to keep the limit of 3°, a deflection pulley has to be used.
- The measuring range/ the **zero point** begins after approximately 2 mm extracted rope. The mechanical reserve at the end of the measuring range is about 20 mm.
- When mounting outdoors protect the sensor and the rope from ice-formation at temperatures below 0 °C.
- Lay the rope preferably in corners or guarded in guidings to prevent pollution or accidental touch.
- When operating the sensor, take care **not to let** the rope **snap back** by mistake or extract the rope **over** the specified **measurement range**, as this might destroy the sensor.
- **Maintenance:** These instruments are maintenance-free. If however, the rope is soiled due to adverse environmental conditions, it should be cleaned with a cloth drenched in resin-free machine oil.



WARNING NOTICES

- Don't let the rope snap back. If the rope is retracted freely, this may lead to injuries (whiplash effect) and the instrument may be damaged. Caution when unhooking and retracting the rope into the sensor.
- Never exceed the specified measurement range when extracting the rope!
- Don't try to open the instrument. The stored energy of the spring drive may lead to injuries when being mishandled.
- Don't touch the rope when operating the sensor.
- Avoid guiding the rope over edges or corners. Use a deflection pulley instead.
- Don't operate the sensor if the rope is buckled or damaged. A ripping of the rope may lead to injuries or damaging the sensor.



SX135 — □ — □ — □

Measurement ranges	10 / 12 / 15 / 20 / 25 / 30 / 35 / 40 / 42.5 m	e.g. 10
---------------------------	--	---------

Easy-Clamp-Mechanismus	F58K
-------------------------------	------

- 0	Version standard sensor with options
--------	---

M4 SSB10 TEMP-40 CO(135)-8 CO(135)	Options M4 rope fixation stainless steel ball bearings temperature range -40...+85 °C HARTCOAT coating for range 8 m HARTCOAT coating for range 10 - 42.5 m
--	---

ORDER CODE ANALOG OUTPUT

SX135 — □ — □ — □ — □

Measurement ranges	8 / 10 / 12 / 15 / 20 / 25 / 30 / 35 / 40 / 42.5 m	e.g. 10
---------------------------	--	---------

Analog output		
potentiometer	1 kOhm	1R
voltage output	0...10 V	10V
current output	4...20 mA	420A

Connection		
M12 connector output axial		SA
cable output axial		KA

- 0	Version standard sensor with options
--------	---

M4 IN L05 SSB8 SSB10 TEMP-40 IP67 CO(135)-8 CO(135) ICP135-8 ICP135	Options M4 rope fixation inverted output signal improved linearity 0.05 % stainless steel ball bearings for range 8 m stainless steel ball bearings for range 10-42,5 m temperature range -40...+85 °C protection class IP67 HARTCOAT coating for range 8 m HARTCOAT coating for range 10 - 42.5 m increased corrosion protection for range 8 m increased corrosion protection for range 10-42.5 m
---	--

ORDER CODE DIGITAL OUTPUT INCREMENTAL

SX135 — □ — □ — □ — □ — □

Measurement ranges	8 / 10 / 12 / 15 / 20 / 25 / 30 / 35 / 40 / 42.5 m	e.g. 10
---------------------------	--	---------

Pulse/ mm		
up to 8 m:	0.28 / 1.4 / 2.8 / 5.6 / 14	e.g. 14
10 m and above:	0.3 / 1.5 / 3 / 6 / 15	e.g. 15

Output type		
Linedriver RS422		L
Push-Pull antivalent		G

Connection		
connector output axial		SR
connector output radial		SA
cable output axial		KA
cable output radial		KR

- 0	Version standard sensor with options
--------	---

M4 M12 K1 K2 K3 L02 IP67 CO(135)-8 CO(135)	Options M4 rope fixation connector output M12 (instead of M23) cable/ connector orientation up cable/ connector orientation left cable/ connector orientation down improved linearity 0.02 % protection class IP67 HARTCOAT coating for range 8 m HARTCOAT coating for range 10 - 42.5 m
--	--

ORDER CODE DIGITAL OUTPUT ABSOLUTE

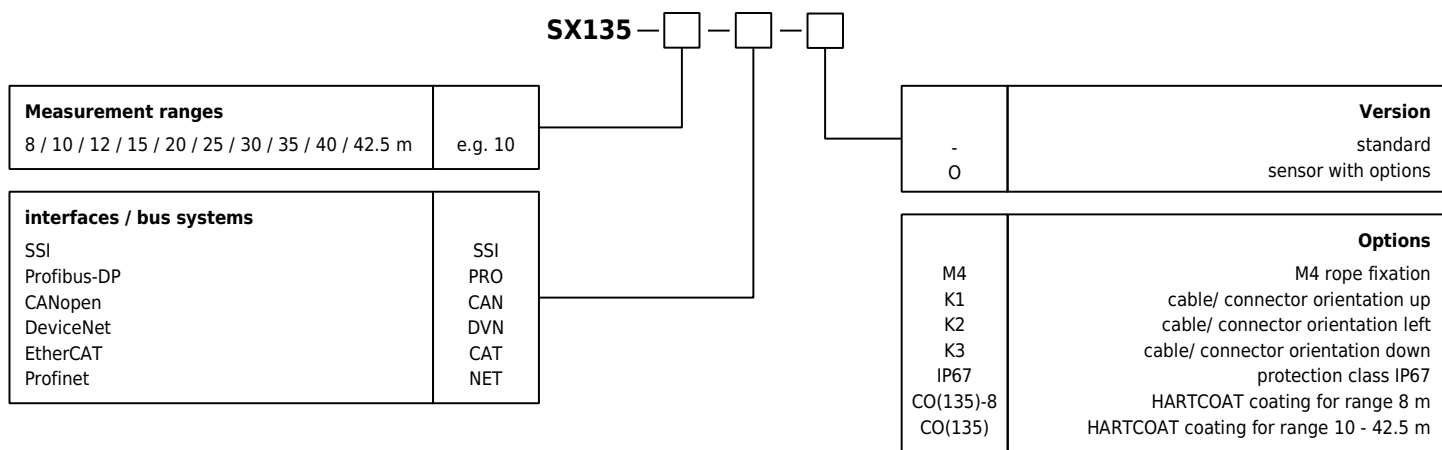

OVERVIEW

Base model draw wire mechanics (for encoder assembly)

- SX135-10-F58K
- SX135-12-F58K
- SX135-15-F58K
- SX135-20-F58K
- SX135-25-F58K
- SX135-30-F58K
- SX135-35-F58K
- SX135-40-F58K
- SX135-42,5-F58K

Base model with potentiometer output

- SX135-8-1R
- SX135-10-1R
- SX135-12-1R
- SX135-15-1R
- SX135-20-1R
- SX135-25-1R
- SX135-30-1R
- SX135-35-1R
- SX135-40-1R
- SX135-42,5-1R

With additional charge on -1R Version:

Analog output

- 10V Voltage output 0...10 V
- 420A Current output 4...20 mA

Digital output incremental

- L/ G Linedriver RS422/ Push-Pull

Digital output absolute

- SSI
- CANopen
- Profibus-DP
- DeviceNet
- EtherCAT
- Profinet

Subject to change without prior notice.