

提夫自控技术（上海）有限公司

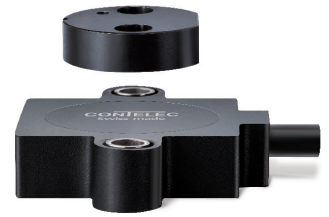

Vert-X 31E - 5V / SSI

Applications

- Concrete pump
- E-Motor feedback system
- Fork lift

Features

- High protection class IP68
- Compact dimensions
- Very fast, non-contacting measuring method
- Very long life
- Applications under adverse ambient conditions possible (humidity, dampness, dust, vibrations etc.)
- Low temperature coefficient of the output signal

Sensor principle		MH-X2
Electrical data		
Measuring range	°	0 ... 360
Indep. linearity (without misalignment)	%	±0.5
Indep. linearity (without allowed misalignment @ 360°)	%	±1
Max. hysteresis	°	0.5
Resolution	bit	12
Max. repeatability	°	0.35
Max. temperature coefficient of the output signal	ppm/°K	5
Power supply voltage	VDC	5 (±10%)
Reverse polarity protection of power supply		no
Redundancy feasible		no
Output driver TTL		
MTTFd / MTBF	years	715 / 715
Current consumption without load (typ.)	mA	18
Recommended ohmic load at output	kOhm	1
Max. capacitive load at output	nF	-
Electrical connection		Cable 4pole
Cross section of single wires	mm ²	0.35 (AWG22)
Output driver Differential RS-485		
MTTFd / MTBF	years	654 / 654
Current consumption without load (typ.)	mA	58
Recommended ohmic load at output	kOhm	0.12
Max. capacitive load at output	nF	-
Electrical connection		Cable 6pole
Cross section of single wires	mm ²	0.25 (AWG24)
Mechanical data		
Mechanical angle	°	360 (continuous)
Protection class		IP68
Min. life	movements	no limitation
Operating & storage temperature	°C	-40 ... +85
IEC 68-2-6 Vibration (Amax = 0.75mm, f = 5 ... 2000 Hz)	g	50
IEC 68-2-27 Shock	g	200
Standards		
EN 55022 class B, Emission radiated (30... 230 MHz)	dB(µV/m)	max. 30
EN 55022 class B, Emission radiated (230...1000MHz)	dB(µV/m)	max. 37
EN 61000-4-2, ESD (contact discharge / air discharge)	kV	±4 / ±8
EN 61000-4-3, Immision HF radiated (80... 1000 MHz)	V/m	30
EN 61000-4-4, Burst (on all lines)	kV	±1
EN 61000-4-5, Surge (lines to ground)	kV	±1
EN 61000-4-6, Immision HF conducted (0.15...80MHz)	Vemk	10
EN 61000-4-8, Immision magnetic field (50Hz)	A/m	300
IEC 60393-1 Insulation resistance (500VDC, 1bar, 2s)	GOhm	20
IEC 60393-1 Dielectric strength (VAC, 50Hz, 1min, 1bar)	kV	1

Errors and omissions excepted. Subject to change without notice. / State: 22.05.13

CONTELEC
A company of the Siedle-Group

提夫自控技术（上海）有限公司

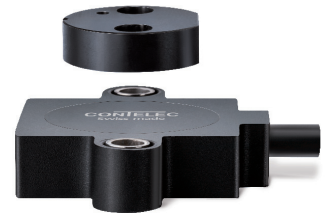

Vert-X 31E - 5V / SSI
Ordering code

		Output characteristics / Output driver				Electrical connection									
		TTL Standard 1				6 Optional Cable 6pole									
		Differential RS-485 Optional 3				8 Standard Cable 4pole									
						9 Optional Special cable									
		Output signal				Length of cable									
		SSI Standard 6				02 Standard 1.0m									
						06 Optional 3.0m									
		Power supply voltage				10 Optional 5.0m									
		5VDC Standard 2				99 Optional Special length									
Vert-X	3	1	E	5	a	6	3	6	2	6	1	8	0	2	
						Electrical angle									
						36 Standard		Electrical angle 360°							
						Sensor principle									
						6 MH-X2									
						Mounting hole									
						a Standard		Through-hole ø 4.4mm							
						b Optional		Through-hole ø 4.4mm with counterbore ø 7.4mm							
						Mechanical version									
						31E5 Standard		Magnetic actuator type 5							
						31E6 Standard		Magnetic actuator type 6							
						31E7 Optional		Magnetic actuator type 7							
						31E9 Optional		Special magnetic actuator							

	MH-X2
Custom magnetic actuator	X
Custom cable	X

Options (on request)

Errors and omissions excepted. Subject to change without notice. / State: 22.05.13



A company of the Siedle-Group

提夫自控技术（上海）有限公司

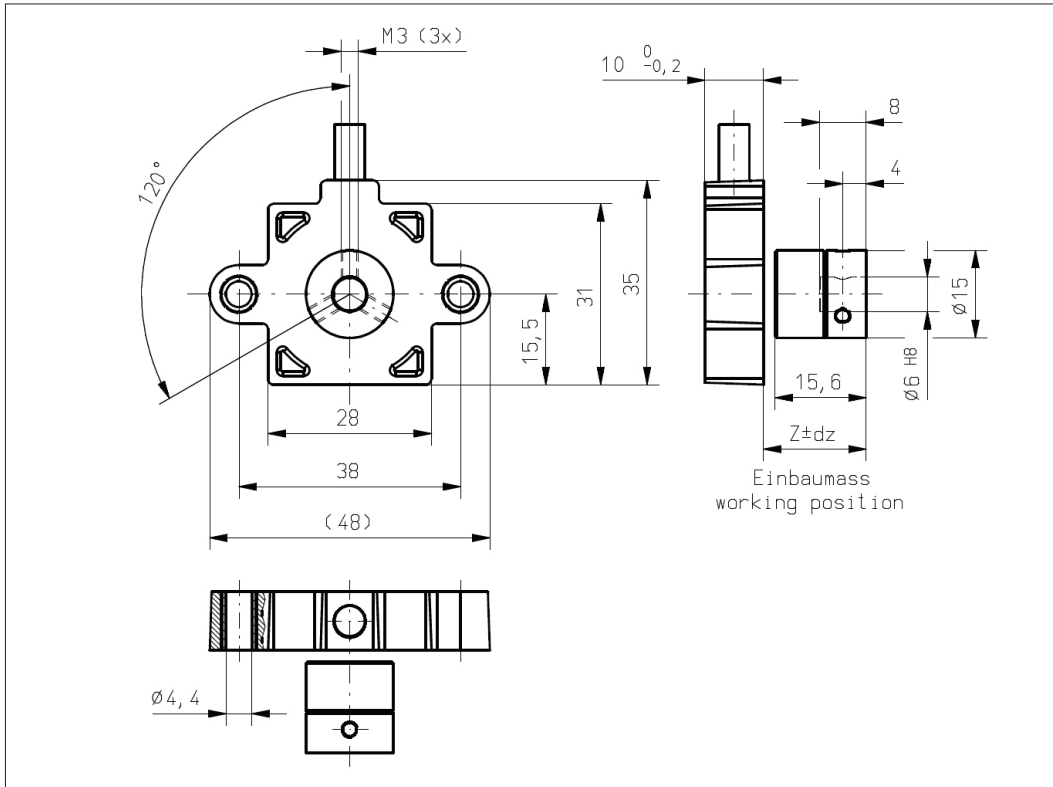

Vert-X 31E5axxx xxx xxx

Accessoires (incl.)

- None

Working position (Z) and max. permitted misalignment of the magnetic actuator

see mounting information

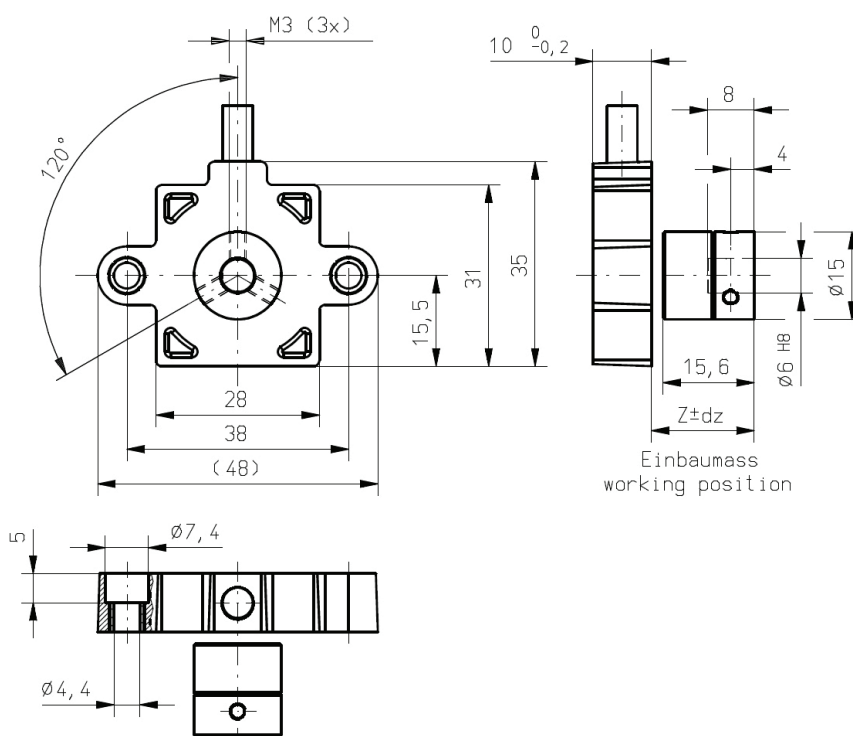

Vert-X 31E5bxxx xxx xxx

Accessoires (incl.)

- None

Working position (Z) and max. permitted misalignment of the magnetic actuator

see mounting information

Errors and omissions excepted. Subject to change without notice. / State: 22.05.13

提夫自控技术（上海）有限公司

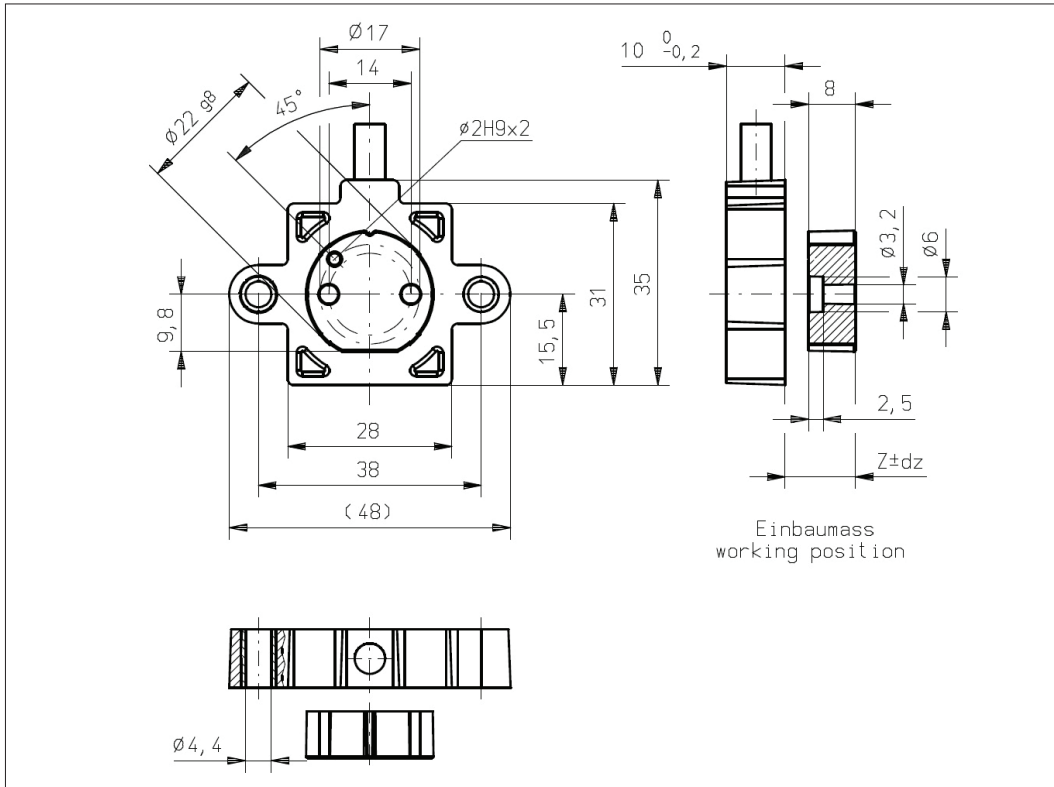
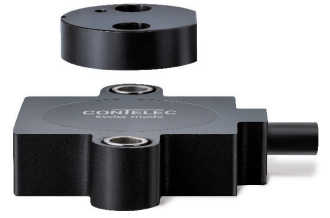

Vert-X 31E6axxx xxx xxx

Accessoires (incl.)

- None

Working position (Z) and max. permitted misalignment of the magnetic actuator

see mounting information

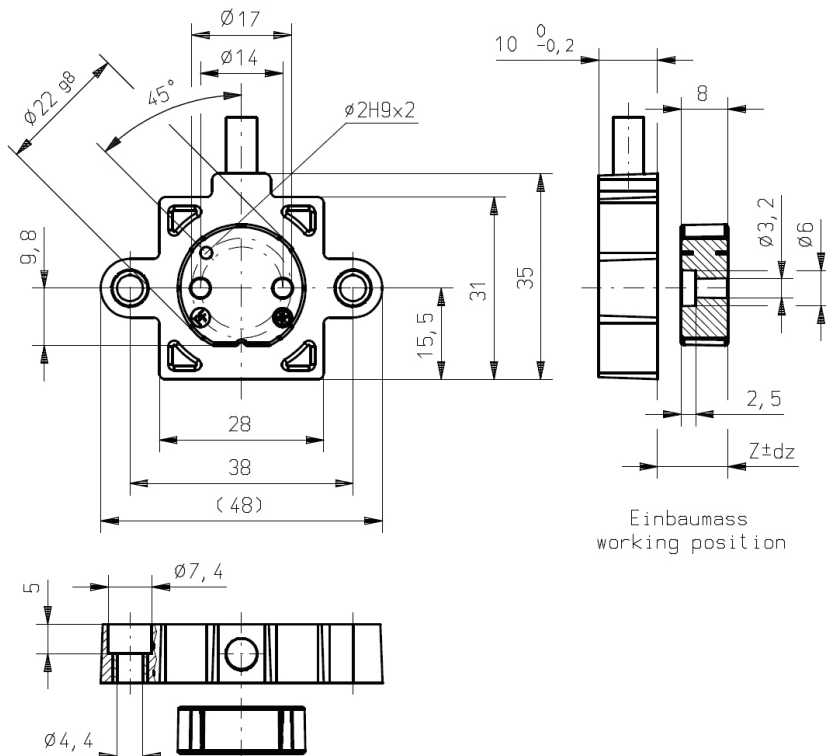

Vert-X 31E6bxxx xxx xxx

Accessoires (incl.)

- None

Working position (Z) and max. permitted misalignment of the magnetic actuator

see mounting information

Errors and omissions excepted. Subject to change without notice. / State: 22.05.13

提夫自控技术（上海）有限公司

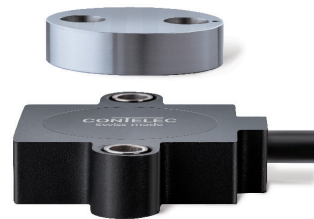

Vert-X 31E7axxx xxx xxx

Accessoires (incl.)

- None

Working position (Z) and max. permitted misalignment of the magnetic actuator

see mounting information

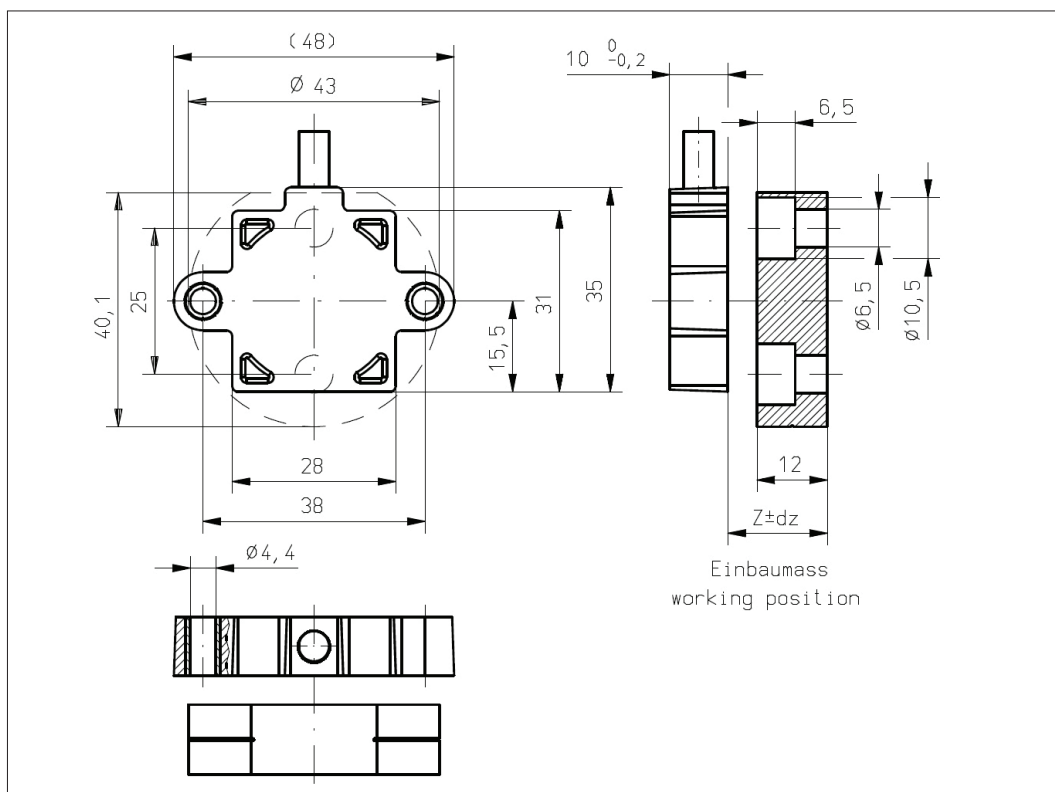

Vert-X 31E7bxxx xxx xxx

Accessoires (incl.)

- None

Working position (Z) and max. permitted misalignment of the magnetic actuator

see mounting information

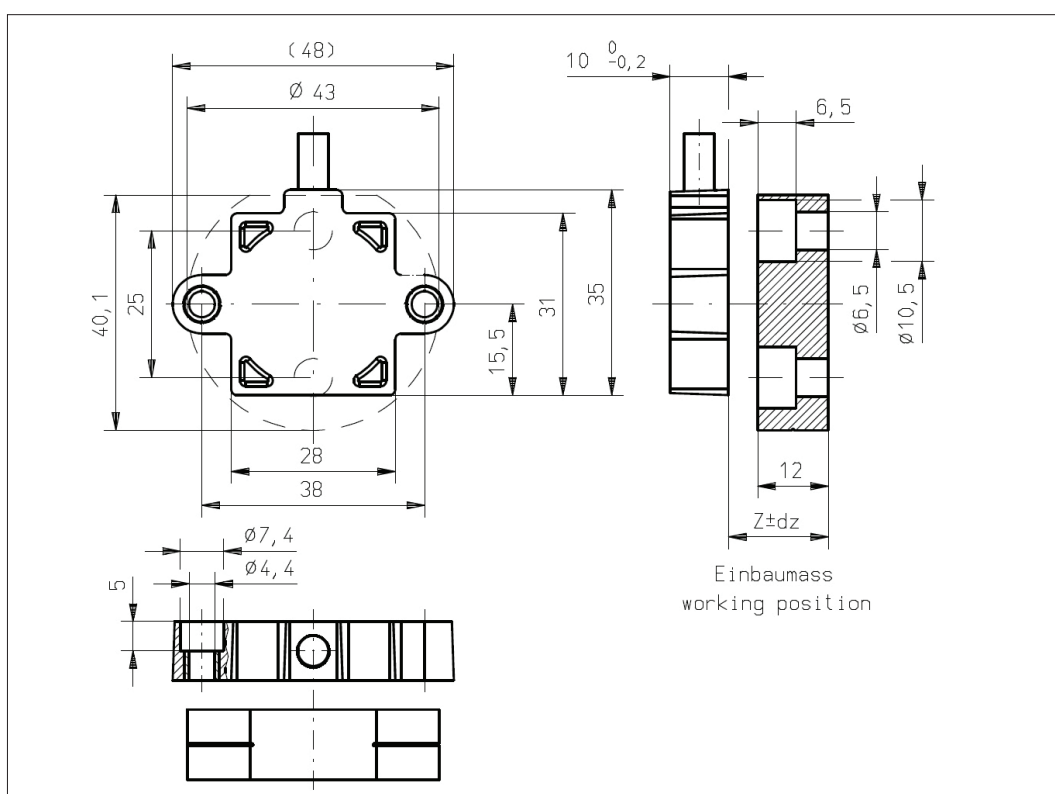

Errors and omissions excepted. Subject to change without notice. / State: 22.05.13

CONTELEC
A company of the Siedle-Group

提夫自控技术（上海）有限公司

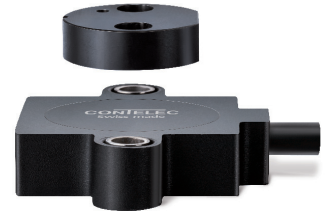

Vert-X 31E5

Mounting information

Working position (Z)
MH-X2 16.10mm

Max. permitted misalignment of the magnetic actuator

dx	±0.50mm
dy	±0.50mm
dz	±0.30mm

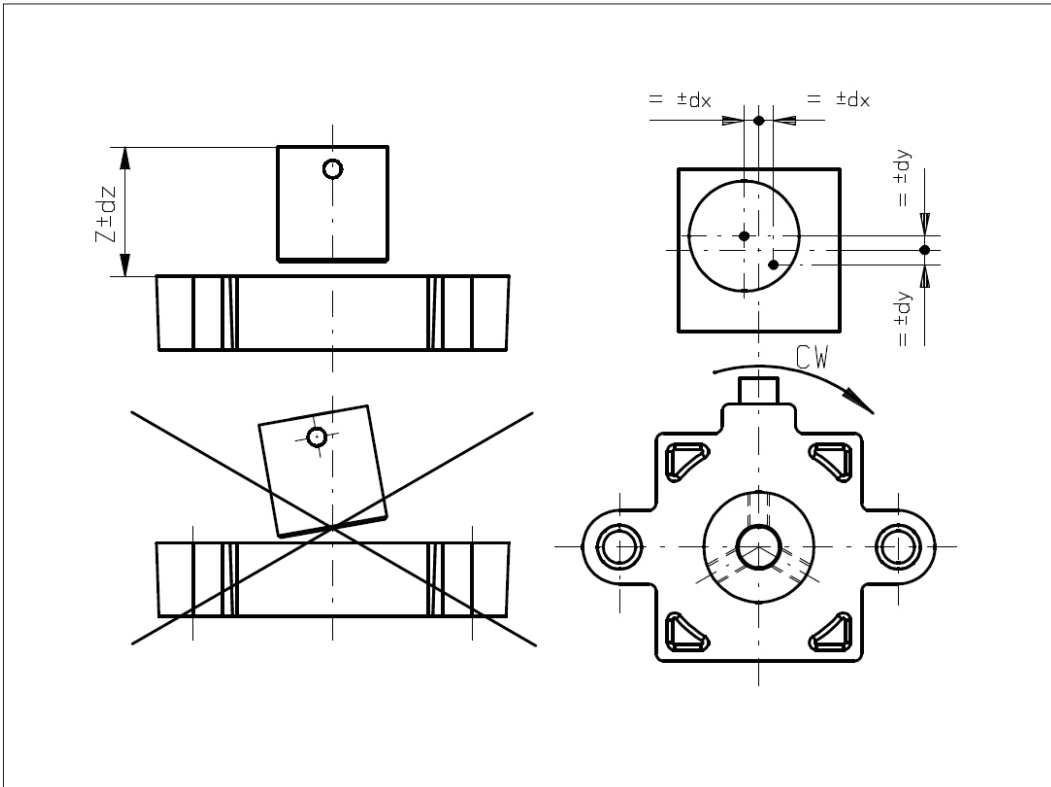

Vert-X 31E6

Mounting information

Working position (Z)
MH-X2 8.70mm

Max. permitted misalignment of the magnetic actuator

dx	±0.50mm
dy	±0.50mm
dz	±0.50mm

Errors and omissions excepted. Subject to change without notice. / State: 22.05.13

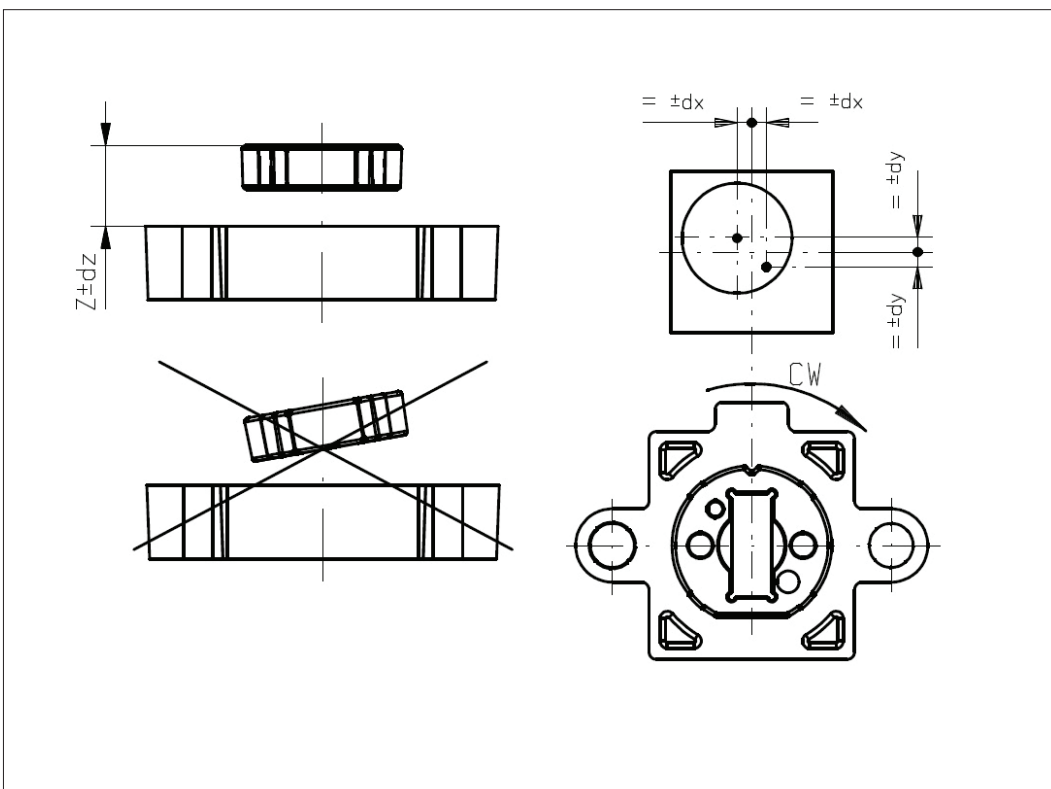

CONTELEC
A company of the Siedle-Group

提夫自控技术（上海）有限公司

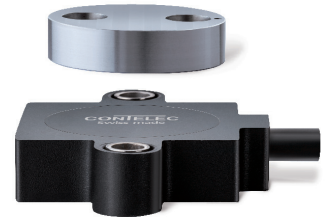

Vert-X 31E7

Mounting information

Working position (Z)
MH-X2 13.00mm

Max. permitted misalign- ment of the magnetic actuator

dx	±1.00mm
dy	±1.00mm
dz	±0.80mm

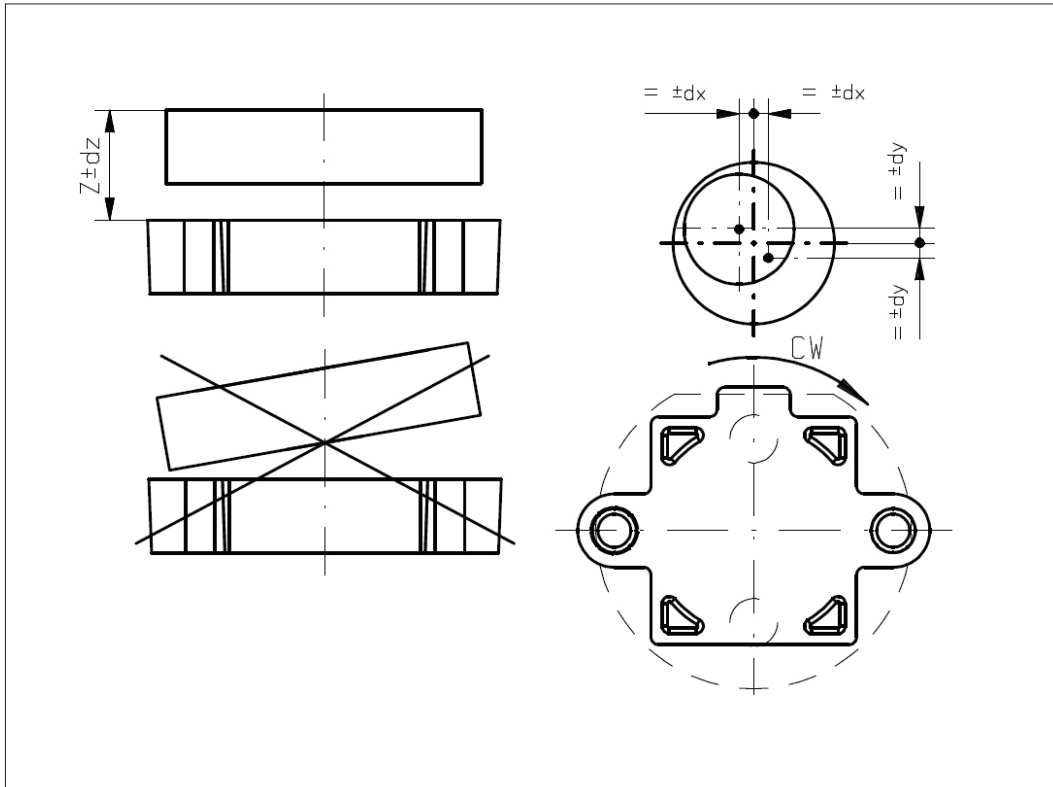

Errors and omissions excepted. Subject to change without notice. / State: 22.05.13