

Bradyprinter™ THT

300X-Plus II

360X-Plus II

600X-Plus II



© 2004 Brady Worldwide Inc.

This copyrighted guide and the label printers described herein are licensed to Brady Corporation. All rights are reserved. Unauthorized reproduction of the guide or the software in the label printer may result in imprisonment of up to one year and fines of up to \$10,000 (17 U.S.C.506). Copyright violators may be subject to civil liability.

IBM® is a registered trademark of IBM Corporation.

Adobe® and Acrobat® are registered trademarks of Adobe Systems Incorporated.

BradyPrinter™ is a trademark of Brady Corporation. BradyConnect® is a registered trademark of Brady Corporation.

ZPL® and ZPL II® are registered trademarks of Zebra Technologies.

All other brand names, product names, or trademarks belong to their respective holders.

Document Name: 13383L-12r1.pdf

Table of Contents

Proprietary Statement	v
Product Improvements	v
FCC Compliance Statement	v
Canadian DOC Compliance Statement	vi
Liability Disclaimer	vi
Limitation of Liability	vi
Warranty Information	ix
Printers and Related Hardware Products	ix
Supplies Products	xi
Repair Services	xi
Warranty Exclusions & Conditions Statement	xi
Printer Software and Firmware License Agreement	xiii
Preface	xix
Contacts	xx
Support	xx
About this Document	xxi
Document Conventions	xxii
Related Documents	xxv

1 • Chapter 1 • Introduction1

Exterior View 2
 Front Panel 3
 Front Panel Buttons 4
 Front Panel Lights 5
 Printer Components 6

2 • Chapter 2 • Getting Started9

Before You Begin. 10
 Unpack and Inspect the Printer. 11
 Report Shipping Damage. 11
 Store or Reship the Printer. 11
 Select a Site for the Printer 12
 Select a Surface. 12
 Provide Proper Operating Conditions 12
 Allow Proper Space 12
 Provide a Data Source. 12
 Connect the Printer to a Power Source. 13
 Power Cord 13
 Communication Interfaces. 15
 Data Cable Requirements 16
 Types of Media 17
 Continuous Media 17
 Non-Continuous Black Mark Media 17
 Non-Continuous Web Media 18
 Ribbon. 19

3 • Chapter 3 • Printer Operation21

Load the Printer. 22
 Load Roll Media. 22
 Load Fanfold Media 24
 Load Ribbon. 26
 Remove Used Ribbon 30
 Print a Configuration Label 31
 Calibrate the Printer 33
 Adjust Sensors 34

Media and Ribbon Sensor Calibration	34
Transmissive (Media) Sensors	36
Adjust the Printhead	39
4 • Chapter 4 • Print Modes41	
Select a Print Mode	42
Tear-Off Mode	42
Peel-Off Mode	43
Cutter Mode	45
Rewind Mode	47
Rewind Mode with Cutter Option	50
Remove Backing from Rewind Spindle	53
5 • Chapter 5 • Data Ports55	
Standard Ports	56
Parallel Port	56
Serial Port	58
USB 2.0 Port	64
6 • Chapter 6 • Memory Cards65	
PCMCIA Card	66
CompactFlash Card	68
7 • Chapter 7 • Front Panel Controls71	
Overview	72
Enter Setup Mode	72
Leave Setup Mode	73
Password-Protected Parameters	74
Default Password Value	75
Disable the Password Protection Feature	75
Front Panel LCD	76
ZebraNet [®] PrintServer II Option Display	98
8 • Chapter 8 • Routine Maintenance101	
Cleaning Schedule	102
Clean Exterior	103
Clean Interior	103

Printhead and Platen Roller 103
Sensors 105
Snap Plate 107
Cutter 108
Replace Fuse 109

9 • Chapter 9 • Troubleshooting111

Troubleshooting. 112
LCD Error Messages. 113
Print Quality Problems. 118
Communications Problems 121
Printer Diagnostics 123
 Power-On Self Test 123
 Additional Printer Self Tests 123
 Communications Diagnostics Test. 127
 Additional Printer Diagnostics 127

10 • Appendix 10 • Specifications129

Features 130
 Standard Features 130
 Print Modes 130
 Zebra Programming Language (ZPL II®). 130
 Bar Codes 131
 Agency Approvals for All Printers 132
 Compliance for All Printers 132
General Specifications. 133
 Electrical Specifications 133
 Environmental Conditions for Operation and Storage 134
Print Specifications by Model 135
Ribbon Specifications by Model 136
Label Specifications. 137
 BP THT 300/600X-Plus II Printers 137
 BP THT 360X-Plus II Printers 140

Index. 143



Proprietary Statement

This manual contains proprietary information of Brady Corporation. It is intended solely for the information and use of parties operating and maintaining the equipment described herein. Such proprietary information may not be used, reproduced, or disclosed to any other parties for any other purpose without the expressed written permission of Brady Corporation.

Product Improvements

Continuous improvement of products is a policy of Brady Corporation. All specifications and designs are subject to change without notice.

FCC Compliance Statement

This equipment has been tested and found to comply with the limits for Class B Digital Devices, pursuant to Part 15 of the FCC Rules. These limits are designed to provide reasonable protection against harmful interference when the equipment is operated in a residential environment. This equipment generates, uses, and can radiate radio frequency energy and, if not installed and used in accordance with the product manuals, may cause harmful interference to radio communications. However, there is no guarantee that interference will not occur in a particular installation. If this equipment does cause harmful interference to radio or television reception the user is encouraged to do one or more of the following measures:

- Reorient or relocate the receiving antenna.
- Increase the separation between the equipment and receiver.
- Connect the equipment into an outlet on a circuit different from that to which the receiver is connected.
- Consult the dealer or an experienced radio/TV technician for help.

The user is cautioned that any changes or modifications not expressly approved by Brady Corporation could void the user's authority to operate the equipment. In order to ensure compliance, this printer must be used with Shielded Communication Cables.

Canadian DOC Compliance Statement

This Class B digital apparatus complies with Canadian ICES-003.

Cet appareil numérique de la classe B est conforme à la norme NMB-003 du Canada.

Liability Disclaimer

Brady Corporation takes steps to assure that its published Engineering specifications and manuals are correct; however, errors do occur. Brady Corporation reserves the right to correct any such errors and disclaims liability resulting therefrom.

Limitation of Liability

In no event shall Brady Corporation or anyone else involved in the creation, production or delivery of the accompanying product (including hardware and software) be liable for any damages whatsoever (including, without limitation, consequential damages including loss of business profits, business interruption or loss of business information) arising out of the use of or the results of use of or inability to use such product, even if Brady Corporation has been advised of the possibility of such damages. Some jurisdictions do not allow the exclusion or limitation of incidental or consequential damages, so the above limitation or exclusion may not apply to you.



DECLARATION of CONFORMITY

BRADY CORPORATION

Declares that the following Information Technology Equipment Desktop_ Series thermal transfer printers, Model -Plus II range: 300X-, 360X-, and 600X-

complies with following applicable directives and standards for the ITE: Residential, Commercial & Light Industry environments

Applicable Directives and Supporting Standards:

89/336/EEC EMC Directive, EN55022:1998 Class B, EN55024:1998
73/23/EEC LVD Directive, EN60950:2000, CB Scheme

FCC Part 15, Subpart B, Class B, FCC Part 15.247, IC RSS-210

NOM 019-SCFI-1998
C-TICK

Manufactured for: Brady Corporation
6555 W. Good Hope Road
Milwaukee, WI 53223, USA

Effective Date: 1 January 2002





Warranty Information

Effective December 30, 2002

All new Brady Corporation products are warranted by the manufacturer to be free from defect in material and workmanship.

Printers and Related Hardware Products

Proof of purchase or shipment date is required to validate the warranty period. The warranty becomes void if the equipment is modified, improperly installed or used, damaged by accident or neglect, or if any parts are improperly installed or replaced by the user.

Products returned must be packaged in the original or comparable packing and shipping container. In the event equipment is not so packaged, or if shipping damage is evident, it will not be accepted for service under warranty. Surface transportation charges for return to customers in the continental United States is paid by Brady Corporation. Otherwise, Brady Corporation pays CPT (carriage paid to) nearest airport; customer pays customs, duties, taxes, and freight from airport to destination. If Brady Corporation determines that the product returned for warranty service or replacement is not defective as herein defined, the customer will pay all handling and transportation costs.



Printers

All printers (excluding printheads) are warranted against defect in material or workmanship for twelve (12) months from the purchase date.

Printheads

Since printhead wear is part of normal operation, the original printhead is covered by a limited warranty as indicated below. Warranty period begins on purchase date.

Printhead	Warranty Period
Bar code label and receipt printer printheads	6 months

To qualify for this warranty, the printhead must be returned to the factory or to an authorized service center. Customers are not required to purchase Genuine Brady Corporation supplies (media and/or ribbons) for warranty qualification.

However, if it is determined that the use of inappropriate or inferior supplies has caused any defect in the printhead for which a warranty claim is made, the user is responsible for Brady Corporation's labor and material charges required to repair the defect. The warranty becomes void if the printhead is physically worn or damaged; also if it is determined that failure to follow the preventive maintenance schedule listed in the Users Guide has caused defect in the thermal printhead for which a warranty claim is made.

Related Hardware Items

Products are warranted to be free of defects in material and workmanship from the date of purchase according to this chart:

Product	Warranty Period
Accessories	1 month
Cables	1 month
Keyboard Display Units	6 months
Parts	3 months
BradyConnect® Print Servers	3 years



Defective product must be returned to Brady Corporation for evaluation. In the event of notification of defect within the warranty period, Brady Corporation will replace the defective item provided there had not been damage resulting from user abuse, modification, improper installation or use, or damage in shipping or by accident or neglect.

Supplies Products

Supplies are warranted to be free from defect in material and workmanship for a period of twelve (12) months for media and twelve (12) months for ribbon from the date of shipment by Brady Corporation. This is provided the user has complied with storage guidelines, handling, and usage of the supplies in Brady Corporation printers.

Brady Corporation's sole obligation under these warranties is to furnish parts and labor for the repair or possible replacement of products found to be defective in material or workmanship during the warranty period. Brady Corporation may in its discretion issue a credit for any such defective products in such amount as it deems reasonable.

Repair Services

Brady Corporation repairs are warranted against defects in material and workmanship for 90 days from the date of repair by Brady Corporation. This excludes printheads, which are warranted separately. This warranty does not cover normal wear and tear. This warranty becomes void if the item is modified, improperly installed or used, or damaged by accident, neglect, or abuse.

Warranty Exclusions & Conditions Statement

The warranties given above are the only warranties given to you. No other warranties, express or implied, are given. Brady Corporation does not make any *implied warranty of merchantability or fitness for a particular purpose* in connection with its sale of products or services. While Brady Corporation's desire is to be responsive to your specific needs and questions, Brady Corporation does not assume responsibility for any specific application to which any products are applied, including, but not limited to, compatibility with other equipment. All statements, technical information, or recommendations relating to Brady Corporation products are based on tests believed to be reliable, but do not constitute a guaranty or warranty.



Brady Corporation's maximum liability for warranty claims is limited to the invoice price of the product claimed defective. Brady Corporation does not assume responsibility for delays in replacement or repair of products. Brady Corporation shall not under any circumstances whatsoever be liable to you or any other party for loss or profits, lost data, diminution of goodwill, or any other special or consequential damages whatsoever with respect to any warranty claim made by you. Specifically for software, Brady Corporation is not liable for any incidental or consequential damages caused by abuse or misapplication of the software or by its use in violation of the U.S. copyright law or international treaty. No salesperson, representative, or agent of Brady Corporation is authorized to make any guaranty, warranty, or representation that contradicts the foregoing. Any waiver, alteration, addition, or modification to the foregoing warranties must be in writing and signed by an executive officer of Brady Corporation to be valid.



Brady Worldwide Identification Solutions

6555 W. Good Hope Rd.

Milwaukee, WI 53201-2131

Phone: 1.800.537.8791

Fax: 1.800.292.2289



Printer Software and Firmware License Agreement

YOU SHOULD CAREFULLY READ THE FOLLOWING TERMS AND CONDITIONS OF THIS PRINTER SOFTWARE AND FIRMWARE LICENSE AGREEMENT (“PSFLA”) BEFORE USING THE SOFTWARE, FIRMWARE OR THE PRINTER WITH WHICH SUCH SOFTWARE OR FIRMWARE IS ASSOCIATED (“Printer”). IF YOU DO NOT AGREE WITH THESE TERMS AND CONDITIONS, DO NOT OPERATE THE SOFTWARE, FIRMWARE OR PRINTER AND PLEASE PROMPTLY RETURN THE PRINTER, ENCLOSURES AND ALL PACKAGING FOR A FULL REFUND.

Brady Corporation (“Brady”) grants you a non-exclusive, non-transferable license to use the Software and Firmware embedded in the printer and the accompanying documentation according to the following terms:

2. GRANT OF LICENSE. This PSFLA grants you the following rights:

- ***Software and Firmware.* The Printer enclosed with or otherwise associated with this Agreement has or includes certain software and firmware therein (the “Software” and “Firmware”) which is protected by copyright laws and international copyright treaties, as well as other intellectual property laws and treaties. The Software and Firmware are licensed, not sold, subject to the terms and restrictions of this PSFLA. You may use, access, display, run, or otherwise interact with (“Run”) the Software and Firmware in connection with**

operating the printer which is enclosed with or otherwise associated with this PSFLA (“Printer”). The primary user of the Printer may make a second copy of the Software for his or her exclusive use on a portable computer/printer.

- *Reservation of Rights.* All rights not expressly granted are reserved by Brady.
- *Accessing Services.* Using the Software and Firmware. Your use of any service accessible using the Software and Firmware is not covered by this PSFLA and may be governed by separate terms of use, conditions or notices. Brady and its suppliers and licensors hereby disclaim any such liability for any such services accessed.

3. RESTRICTIONS.

- *Copyright Notices.* You must maintain all copyright notices on all copies of the Software and Firmware.
- *Limitations on certain uses and modification.* You may not modify, adapt, translate, or create derivative works based on this Software or Firmware or the accompanying documentation. You may not use the Software or Firmware in any manner that violates the rights of third parties.
- *Limitations of Reverse Engineering, Decompilation and Disassembly.* You may not reverse engineer, decompile, or disassemble the Software or the Firmware, except and only to the extent that such activity is permitted by applicable law notwithstanding this limitation.
- *Sublicense.* You may not sublicense, distribute, rent, lease, supply, market or lend Software or Firmware to any other party.
- *Support Services.* Brady may provide you with support services related to the Software and/or Firmware (“Support Services”), in its discretion. Use of Support Services, if any, is governed by the Brady policies and programs described in the user guide, in online documentation, and/or other Brady-provided materials as modified by Brady from time to time. Any supplemental Software or Firmware code provided to you as a part of Support Services shall be considered part of the Software and/or Firmware and is subject to the terms of this PSFLA.
- *Replacement, Modification and Upgrade of the Software and/or Firmware.* Brady reserves the right to replace, modify or upgrade the Software and/or Firmware at any time by offering you a replacement or modified version of the Software and/or Firmware or such upgrade and to charge for such replacement, modification or upgrade. Any such replacement or modified Software and/or Firmware code or upgrade to the Software and/or Firmware offered to you by Brady shall be considered part of the Software and/or Firmware and subject to the terms of this PSFLA (unless this PSFLA is superseded by a further PSFLA accompanying such replacement or modified version of or upgrade to the Software and/or Firmware). In the event that Brady offers a replacement or modified version of or any upgrade to the Software and/or Firmware, (a) your continued use of the Software and/or

Firmware is conditioned on your acceptance of such replacement or modified version of or upgrade to the Software and/or Firmware and any accompanying superseding PSFLA and (b) in the case of the replacement or modified Software and/or Firmware, your termination of all use of all prior versions of the Software and/or Firmware.

4. **TERMINATION.** Without prejudice to any other rights, Brady may terminate this PSFLA if you fail to comply with the terms and conditions of this PSFLA. In the event that Brady terminates this PSFLA, you must immediately stop using the Software and/or Firmware, destroy all copies of the Software and/or Firmware and all of its component parts, and, upon request, provide an affidavit certifying your compliance with the foregoing.
5. **PROPRIETARY RIGHTS.** All title and copyrights in and to the Software, Firmware, the accompanying printed materials, and any copies of the Software and Firmware, are owned by Brady or its suppliers. All title and intellectual property rights in and to the content which may be accessed through use of the Software and/or Firmware are the property of the respective content owners and may be protected by applicable copyright or other intellectual property laws and treaties. This PSFLA grants you no rights to use such content. If this Software and/or Firmware contains documentation which is provided only in electronic form, you may print one copy of such electronic documentation. You may not copy the printed materials accompanying the Software and/or Firmware.
6. **U.S. GOVERNMENT RESTRICTED RIGHTS.** All Software, Firmware and/or documentation provided to the U.S. Government pursuant to solicitations issued on or after December 1, 1995 is provided with the commercial rights and restrictions described elsewhere herein. All Software and/or Firmware provided to the U.S. Government pursuant to solicitations issued prior to December 1, 1995 is provided with RESTRICTED RIGHTS as provided for in FAR, 48 CFR 52.227-19 (JUNE 1987) or DFARS, 48 CFR 252.227-7013 (OCT 1988), as applicable.
7. **EXPORT RESTRICTIONS.** You agree that you will not export or re-export the Software and/or Firmware, any part thereof, or any process or service that is the direct product of the Software and/or Firmware (the foregoing collectively referred to as the “Restricted Components”), to any country, person or entity subject to U.S. export restrictions. You specifically agree not to export or re-export any of the Restricted Components: (i) to any country to which the U.S. has embargoed or restricted the export of goods or services, which currently include, but are not necessarily limited to Cuba, Iran, Iraq, Libya, North Korea, Sudan and Syria, or to any national of any such country, wherever located, who intends to transmit or transport the Restricted Components back to such country; (ii) to any person or entity who you know or have reason to know will utilize the Restricted Components in the design,

development or production of nuclear, chemical or biological weapons; or (iii) to any person or entity who has been prohibited from participating in U.S. export transactions by any federal agency of the U.S. government. You warrant and represent that neither the U.S. Commerce Department, Bureau of Export Administration nor any other U.S. federal agency has suspended, revoked or denied your export privileges.

8. **DISCLAIMER OF WARRANTIES. BRADY AND ITS SUPPLIERS AND/OR LICENSORS PROVIDE THE SOFTWARE AND/OR FIRMWARE “AS IS” AND WITH ALL FAULTS, AND HEREBY DISCLAIM ALL WARRANTIES AND CONDITIONS, EITHER EXPRESS, IMPLIED OR STATUTORY, INCLUDING BUT NOT LIMITED TO ANY (IF ANY) IMPLIED WARRANTIES OR CONDITIONS OF MERCHANTABILITY, FITNESS FOR A PARTICULAR PURPOSE, LACK OF VIRUSES, AND LACK OF NEGLIGENCE OR LACK OF WORKMANLIKE EFFORT. ALSO, THERE IS NO WARRANTY OR CONDITION OF TITLE, OF QUIET ENJOYMENT, OR OF NONINFRINGEMENT. THE ENTIRE RISK ARISING OUT OF THE USE OR PERFORMANCE OF THE SOFTWARE AND FIRMWARE IS WITH YOU. BRADY DOES NOT WARRANT THAT THE OPERATION OF THE SOFTWARE OR FIRMWARE WILL BE UNINTERRUPTED OR ERROR FREE. WITHOUT LIMITING THE GENERALITY OF THE FOREGOING, TO THE EXTENT THAT THE SOFTWARE AND/OR FIRMWARE COVERED BY THIS PSFLA INCLUDES EMULATION LIBRARIES, SUCH EMULATION LIBRARIES DO NOT WORK 100% CORRECTLY OR COVER 100% OF THE FUNCTIONALITY OF THE PRINTER LANGUAGE BEING EMULATED, ARE OFFERED “AS IS” AND WITH ALL FAULTS AND ALL THE FOREGOING DISCLAIMERS AND LIMITATIONS CONTAINED IN THIS PARAGRAPH APPLY TO SUCH EMULATION LIBRARIES.**
9. **EXCLUSION OF ALL DAMAGES. TO THE MAXIMUM EXTENT PERMITTED BY APPLICABLE LAW, IN NO EVENT SHALL BRADY OR ITS SUPPLIERS OR LICENSORS BE LIABLE FOR ANY CONSEQUENTIAL, INCIDENTAL, DIRECT, INDIRECT, SPECIAL, PUNITIVE, OR OTHER DAMAGES WHATSOEVER (INCLUDING, WITHOUT LIMITATION, DAMAGES FOR ANY INJURY TO PERSON OR PROPERTY, DAMAGES FOR LOSS OF PROFITS, BUSINESS INTERRUPTION, LOSS OF BUSINESS INFORMATION, FOR LOSS OF PRIVACY, FOR FAILURE TO MEET ANY DUTY INCLUDING THE DUTIES OF GOOD FAITH OR OF REASONABLE CARE, FOR NEGLIGENCE, AND FOR ANY PECUNIARY OR OTHER LOSS WHATSOEVER) ARISING OUT OF OR IN ANY WAY RELATED TO THE USE OF OR INABILITY TO USE THE SOFTWARE OR FIRMWARE (INCLUDING, WITHOUT LIMITATION, ANY EMULATION LIBRARY**

CONTAINED THEREIN), WHETHER BASED ON CONTRACT, TORT, NEGLIGENCE, STRICT LIABILITY OR OTHERWISE, EVEN IF BRADY OR ANY SUPPLIER HAS BEEN ADVISED OF THE POSSIBILITY OF SUCH DAMAGES. THIS EXCLUSION OF DAMAGES SHALL BE EFFECTIVE EVEN IF ANY REMEDY FAILS OF ITS ESSENTIAL PURPOSE.

- 10. BRADY SUPPLIERS AND LICENSORS.** ANY RELEASE, DISCLAIMER OR LIMITATION OF BRADY'S LIABILITY OR DAMAGES PURSUANT TO THIS AGREEMENT SHALL BE CONSTRUED, IN ADDITION TO BRADY'S BENEFIT, ALSO TO THE BENEFIT OF BRADY'S SUPPLIERS, LICENSORS, EMPLOYEES, AND CONTRACTORS AND, WITHOUT LIMITING ANY OTHER DEFENSES THAT SUCH SUPPLIERS, LICENSORS, EMPLOYEES AND CONTRACTORS MAY HAVE, YOU AGREE TO RELEASE SUCH PARTIES FROM LIABILITY OR DAMAGES IN ACCORDANCE WITH SUCH RELEASE, DISCLAIMER, OR LIMITATION OF LIABILITY OR DAMAGES TO THE SAME EXTENT THAT SUCH PROVISIONS APPLY TO BRADY.
- 11. GOVERNING LAW.** To the maximum extent permitted by law, the laws of the State of Wisconsin, U.S.A., without regard to its conflicts of laws provisions, will apply to this contract. Also, to the maximum extent permitted by applicable law, the parties irrevocably agree that any litigation involving the PSFLA, the Software, Firmware or Printer shall be brought in the state or federal courts in the State of Wisconsin. You agree that you shall not assert any claim that you are not subject to the jurisdiction of such courts, that the venue is improper, that the forum is inconvenient or any similar objection, claim or argument.
- 12. INJUNCTIVE RELIEF.** You acknowledge that, in the event you breach any provision of this Agreement, Brady will not have an adequate remedy in money or damages. Brady shall therefore be entitled to obtain an injunction against such breach from any court of competent jurisdiction immediately upon request without posting bond. Brady's right to obtain injunctive relief shall not limit its right to seek further remedies.
- 13. ENTIRE AGREEMENT.** This Agreement constitutes the entire understanding and agreement of the parties, and supersedes any and all prior or contemporaneous representation, understandings and agreements, between the parties with respect to the subject matter of this Agreement. **If any provision of this PSFLA is held invalid, the remainder of this PSFLA shall continue in full force and effect.**
- 14. ASSIGNMENT.** You may not assign this PSFLA or any of your rights hereunder (by operation of law or otherwise) without Brady's prior written consent. Brady may assign this Agreement without your consent. Subject to the foregoing, this PSFLA shall be binding upon and inure to the benefit of

the parties to it and their respective legal representatives, successors and permitted assigns.

15. **CONFIDENTIAL INFORMATION.** You acknowledge that the Software and Firmware embody confidential information owned by Brady and/or its licensors. To the extent you have access to any such information, you agree to use such information only for the authorized use of the Software and Firmware. You further agree not to disclose such confidential information to any other party and to use at least the same degree of care to maintain the confidential nature of such information as you use to maintain the confidentiality of your own confidential information.
16. **MODIFICATION.** No modification of this Agreement shall be binding unless it is in writing and is signed by an authorized representative of the party against whom enforcement of the modification is sought.
17. **WAIVER.** The failure by a party to exercise any right hereunder shall not operate as a waiver of such party's right to exercise such right or any other right in the future.
18. **QUESTIONS.** **Should you have any questions, or if you desire to contact Brady for any reason, please contact the Brady subsidiary serving your country, or write:** Brady Corporation, 6555 West Good Hope Road, Milwaukee, WI. 53223.



Preface

This section provides you with contact information, document structure and organization, and additional reference documents.

Contents

- Contacts xx
- Support xx
- About this Documentxxi
- Document Conventions xxii
- Related Documentsxxiv

Contacts

You can contact Brady Corporation at any of the following:

Visit us at: www.bradyid.com

Our Mailing Address:

Brady Worldwide Identification Solutions

6555 West Good Hope Road

P.O. Box 2131

Milwaukee, WI 53201-2131

Telephone: +1.800.537.8791

Fax: +1 800.292.2289

Support

You can contact Brady Technical Support at:

Web address: www.bradyid.com.

Phone Number 1.800.643.8766

About this Document

The *X-Plus II Series User Guide* contains the following chapters and appendices:

Chapter Number	Title	Content
	<i>Warranty Information</i>	Warranty information on Brady printers, related hardware, and supplies.
1	<i>Introduction</i>	Printer overview, printer components, types of labels, and system considerations.
2	<i>Getting Started</i>	Instructions for setting up your printer.
3	<i>Printer Operation</i>	Instructions for loading media, loading and removing ribbon, calibrating the printer, adjusting sensors, and adjusting the printhead.
4	<i>Print Modes</i>	Descriptions of the available print options.
5	<i>Data Ports</i>	Standard data ports available on the printer.
6	<i>Memory Cards</i>	PCMCIA and CompactFlash card options available.
7	<i>Front Panel Controls</i>	How to adjust printer settings to fit your printing needs.
8	<i>Routine Maintenance</i>	Routine cleaning and maintenance procedures.
9	<i>Troubleshooting</i>	Common printing problems and recommended solutions.
A	<i>Specifications</i>	Printer specifications, such as operating temperatures and power requirements.

Document Conventions

The following conventions are used throughout this document to convey certain information:

About this Chapter Sections This section includes a brief overview of and a table of contents for the chapter. These sections primarily serve as hyperlink components for the Adobe Acrobat .pdf version of this guide.

Alternate Color (online only) Cross-references contain hot links to other sections in this guide. If you are viewing this guide online in .pdf format, you can click the cross-reference ([blue text](#)) to jump directly to its location.

Command Line Examples All command line examples appear in Courier New font. For example, you would type the following to get to the Post-Install scripts in the bin directory:

```
Ztools
```

Files and Directories All file names and directories appear in Courier New font. For example, the Brady<version number>.tar file and the /root directory.

Cautions, Important, Note, and Example



Caution • Warns you of a potential electric shock situation.



Caution • Warns you of a situation where excessive heat could cause a burn.



Caution • Advises you that failure to take or avoid a specific action could result in physical harm to you.

Caution • Advises you that failure to take or avoid a specific action could result in physical harm to the hardware.



Important • Advises you of information that is essential to complete a task.



Note • Indicates neutral or positive information that emphasizes or supplements important points of the main text.



Example • Provides an example, often a scenario, to better clarify a section of text.



Tools • Tells you what tools you need to complete a given task.

Illustration Callouts Callouts are used when an illustration contains information that needs to be labeled and described. A table that contains the labels and descriptions follows the graphic. The following illustration and table provide an example.

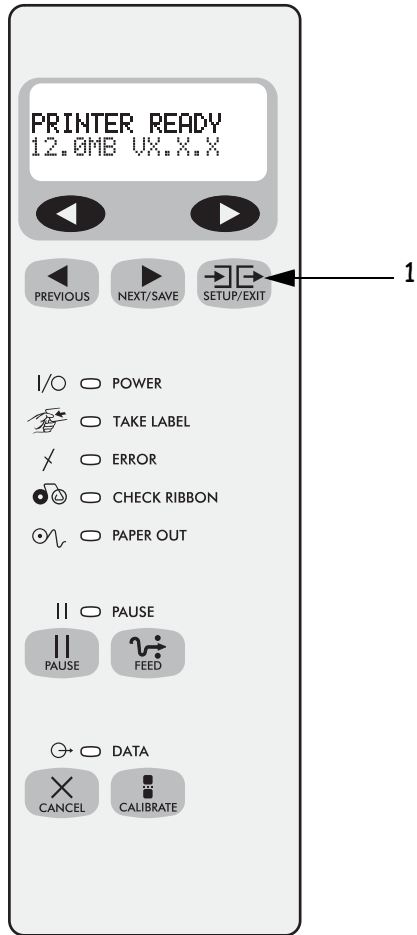

1 SETUP/EXIT button

Related Documents

In addition to the *X-Plus II Series User Guide*, the following documents might be helpful references:

- *ZPL II[®] Programming Guide Volume I* (part number 45541L) and *Volume II* (part number 45542L).
- *PrintServer II[™] Installation and User Guide* (part number 45537L).
- *Maintenance Manual* (part number 13185L-12 for the 300 and 600 X-Plus II Series printers; part number 48152L-12 for the 360 X-Plus II Series printer).



CHAPTER 1

Introduction

This chapter provides a high-level overview of the printer and its components.

Contents

Exterior View	2
Front Panel	3
Front Panel Buttons	4
Front Panel Lights	5
Printer Components	6

Exterior View

The following illustrations show the exterior of the printer.

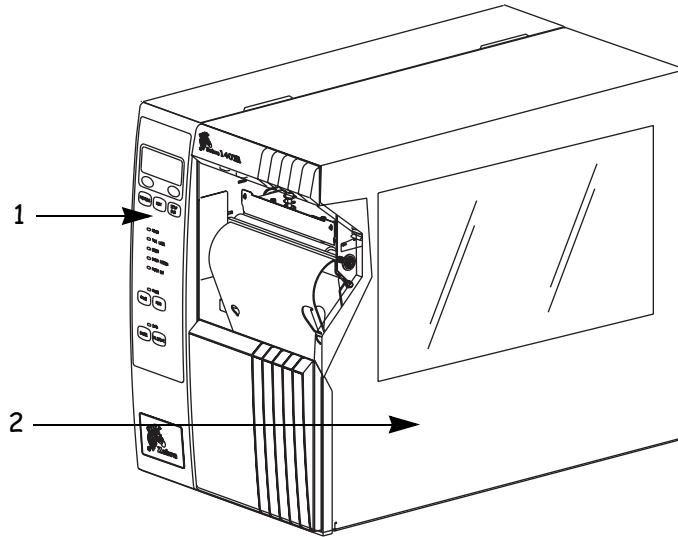

-
- 1 Front panel
 - 2 Media door
-

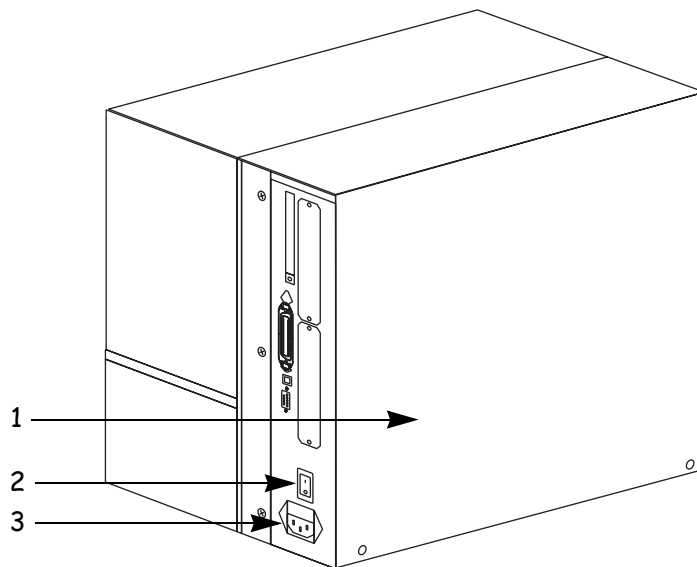

-
- 1 Electronics cover
 - 2 Power switch
 - 3 AC power cord connection
-





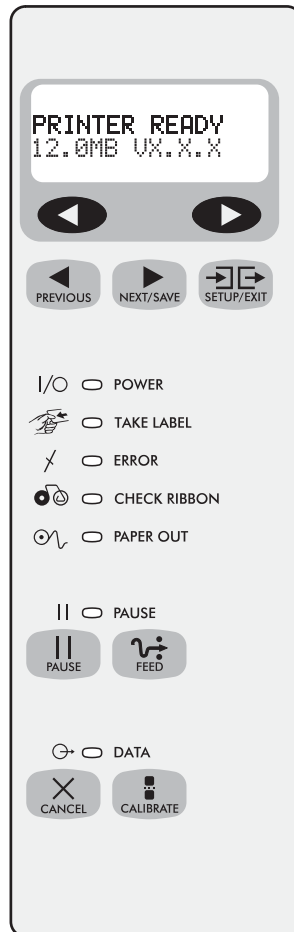



Front Panel

This illustration shows the buttons and lights on the front panel. For details, see *Front Panel Buttons* on page 4 and *Front Panel Lights* on page 5.









Front Panel Buttons

This table describes the function of the buttons shown in the illustration on [page 2](#).

Button	Details
LEFT OVAL 	Changes parameter values. Common uses are to increase/decrease a value, answer yes or no , indicate on or off , scroll through several choices, input the password, or set up the printer for a firmware download.
RIGHT OVAL 	Changes parameter values. Common uses are to increase/decrease a value, answer yes or no , indicate on or off , scroll through several choices, input the password, or set up the printer for a firmware download.
PREVIOUS 	Scrolls to the previous parameter. Press and hold this button to scroll back quickly through parameter sets.
NEXT/SAVE 	Scrolls to the next parameter. Press and hold this button to scroll forward quickly through parameter sets.
SETUP/EXIT 	Enters and exits the setup mode.
PAUSE 	Starts and stops the printing process and allows other buttons to be used. If an error messages is on the LCD, pressing this button removes the error.
FEED 	Forces the printer to feed a blank label each time the button is pressed. <ul style="list-style-type: none"> • If the printer is not printing, one blank label immediately feeds. • If the printer is printing, one blank label feeds after the current batch of labels is complete.
CANCEL 	In the pause mode, this button cancels print jobs. <ul style="list-style-type: none"> • If there are multiple print jobs in the print queue, press CANCEL once for each print job to be deleted. • To delete all print jobs, hold CANCEL for several seconds. The DATA light turns off.
CALIBRATE 	This button can be used to calibrate the printer for the following: <ul style="list-style-type: none"> • Media length • Media type (continuous or non-continuous) • Print mode (direct thermal or thermal transfer) • Sensor values For more information on calibration, see <i>Calibrate the Printer</i> on page 33 .

Front Panel Lights

This table details the lights shown in the illustration on [page 2](#).

Light	Details
POWER 	Indicates printer power status. <ul style="list-style-type: none"> • Off — printer is off. • On — printer is on.
TAKE LABEL 	<ul style="list-style-type: none"> • Off — Normal operation. • Flashing — (<i>Peel-Off Mode only.</i>) The label is available. Printing is paused until the label is removed.
ERROR 	Indicates printer operation. <ul style="list-style-type: none"> • Off — printer is in Normal operation. • Flashing — printer pauses until the label is removed.
CHECK RIBBON 	<ul style="list-style-type: none"> • Off — Normal operation; ribbon (if used) is properly loaded. • On — No media is under the label sensor. Printing is paused, the LCD shows an error message, and the PAUSE light is on.
PAPER OUT 	Indicates that labels need to be reloaded.
PAUSE 	<ul style="list-style-type: none"> • Off — normal operation. • On — all printing operations have stopped. Either PAUSE was pressed, a pause command was included in the label format, the on-line verifier detected an error, or a printer error was detected.
DATA 	<ul style="list-style-type: none"> • Off — Normal operation. No data being received or processed. • On/Blinking — Data processing or printing is taking place. Data is being received.

Printer Components

This illustration shows a side view of the printer's internal components.



Note • Depending on the printer options that you selected, your printer could look slightly different. For more about printer options, go to www.bradyd.com.

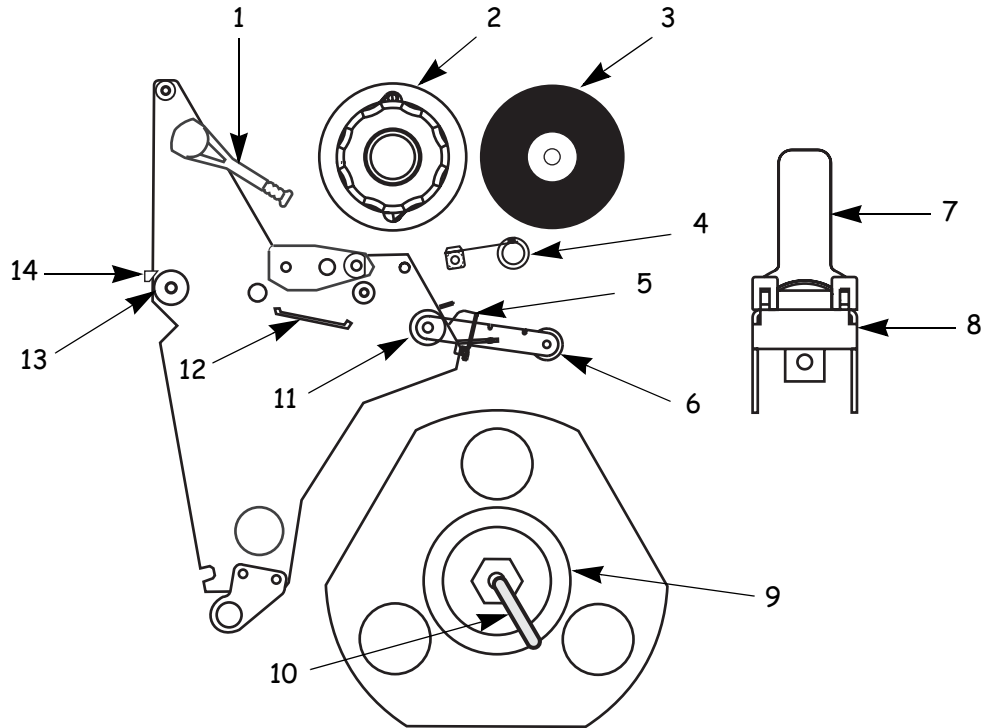

-
- 1 Printhead lever
 - 2 Ribbon take-up spindle
 - 3 Ribbon supply spindle
 - 4 Ribbon dancer assembly (only on select models)
 - 5 Media guide
 - 6 Media dancer roller assembly
 - 7 Media supply guide
 - 8 Media supply hanger
 - 9 Rewind spindle (optional)
 - 10 Spindle hook
 - 11 Lower roller
 - 12 Snap plate
 - 13 Platen roller
 - 14 Tear-off bar
-



Introduction

Printer Components



CHAPTER 2

Getting Started

This chapter provides the tasks that you must complete and the issues that you must consider before you load and configure your printer.

Contents

Before You Begin	10
Unpack and Inspect the Printer	11
Report Shipping Damage	11
Store or Reship the Printer	11
Select a Site for the Printer	12
Select a Surface	12
Provide Proper Operating Conditions	12
Allow Proper Space	12
Provide a Data Source	12
Connect the Printer to a Power Source	13
Power Cord	13
Communication Interfaces	15
Data Cable Requirements	16
Types of Media	17
Continuous Media	17
Non-Continuous Black Mark Media	17
Non-Continuous Web Media	18
Ribbon	19

Before You Begin

Review this checklist, and resolve any issues before you begin setting up your printer. When you are ready, continue with *Printer Operation* [on page 21](#).

- Unpack and Inspect** Have you unpacked the printer and inspected it for damage? If you have not, see *Unpack and Inspect the Printer* [on page 11](#).
- Select a Site** Have you selected an appropriate location for the printer? If you have not, see *Select a Site for the Printer* [on page 12](#).
- Attach Power Cord** Do you have the correct power cord for your printer? If you are unsure, see *Power Cord* [on page 13](#). To attach the power cord and connect the printer to a power source, see *Connect the Printer to a Power Source* [on page 13](#).
- Connect to a Data Source** Have you determined how the printer will be connected to a data source (usually a computer)? For more information, see *Communication Interfaces* [on page 15](#).
- Select Media** Do you have the correct media for your application? If you are unsure, see *Types of Media* [on page 17](#).
- Select Ribbon** Do you need to use ribbon, and is the appropriate ribbon available, if needed? If you are unsure, see *Ribbon* [on page 19](#).

Unpack and Inspect the Printer

When you unpack the printer, save all packing materials. When the printer is out of the box, raise the printer's media door, and remove the power cord.

Inspect the printer for possible damage incurred during shipment. Check all exterior surfaces for damage. Raise the media door, and inspect the media compartment for damage to components.

Report Shipping Damage

If you discover shipping damage upon inspection:

- Immediately notify the shipping company of the damage, and file a damage report with them. Brady is not responsible for any damage incurred during shipment of the equipment and does not repair this damage under warranty.
- Keep all packaging material for shipping company inspection.
- Notify your authorized Brady distributor.

Store or Reship the Printer

If you are not placing the printer into immediate operation, repackage it using the original packing materials. You may store the printer under the following conditions:

- Temperature: -40° to 140° F (-40° to 60° C)
- Relative humidity: 5% to 85% non-condensing

If you must ship the printer, remove any ribbon and media from the supply spools to avoid damaging the printer. Carefully pack the printer into the original container or a suitable alternate container to avoid damage during transit.

Select a Site for the Printer

Consider the following when selecting an appropriate location for your printer.

Select a Surface

Select a solid, level surface of sufficient size and strength to accommodate the printer and other equipment (such as a computer), if necessary. The choices include a table, countertop, desk, or cart.

Provide Proper Operating Conditions

Because the printer was designed and is fabricated as an industrial-type unit, it functions satisfactorily in a location that conforms to specified environmental and electrical conditions, including a warehouse or factory floor. For more information on the required conditions, see *General Specifications* on page 133.

The following table shows the temperature and relative humidity requirements for the printer when it is operating.

Mode	Temperature	Relative Humidity
Thermal Transfer	41° to 104°F (5° to 40°C)	20 to 85% non-condensing
Direct Thermal	32° to 104°F (0° to 40°C)	20 to 85% non-condensing

Allow Proper Space

The printer should have enough space around it for you to be able to open the media door. To allow for proper ventilation and cooling, leave open space on all sides of the printer.

Caution • Do not place any padding or cushioning material behind or under the printer because this restricts air flow and could cause the printer to overheat.

Provide a Data Source

If the printer will be located away from the data source, the selected site must provide the appropriate connections to that data source. For more information on the types of communication interfaces, see *Communication Interfaces* on page 15.

Connect the Printer to a Power Source



Caution • For personnel and equipment safety, always use an approved three-conductor power cord specific to the region or country intended for installation. This cord must use an IEC 320 female connector and the appropriate region-specific three-conductor grounded plug configuration.

To connect the printer to a power source, complete these steps:

1. Turn the printer power switch (located on the rear of the printer) to the Off (O) position.
2. Plug the power cord into the mating connector on the rear of the printer.
3. Plug the other end of the power cord into the power source.

Power Cord

Depending on how your printer was ordered, a power cord may or may not be included. If one is not included or if the one included is not suitable for your requirements, refer to the following guidelines.

Your power cord must meet these standards:

- The overall length must be less than 9.8 ft (3.0 m).
- It must be rated for at least 5 A, 250 V.
- The chassis ground (earth) **must** be connected to ensure safety and reduce electromagnetic interference.

The ground connection is handled by the third wire (earth) in the power cord as shown in the following illustration.

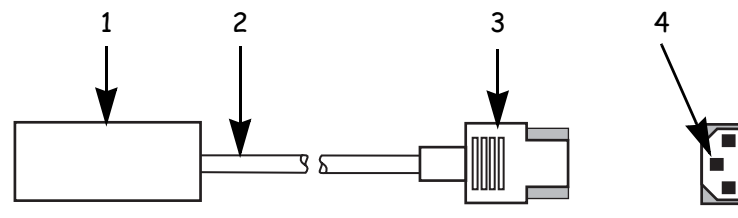

-
- | | |
|---|------------------------------------|
| 1 | AC power plug for your country |
| 2 | 3-conductor HAR cable |
| 3 | IEC 320 connector |
| 4 | Neutral earth live in contact view |
-

Getting Started

Connect the Printer to a Power Source

- The AC power plug and the IEC 320 connector must bear the certification mark of at least one of the known international safety organizations shown in this illustration.

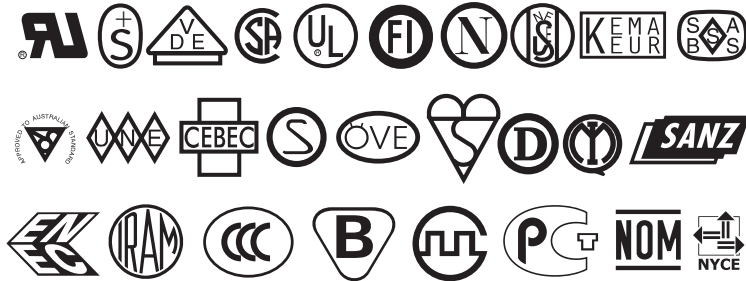

Communication Interfaces

The way that you connect your printer to a data source depends on the communication options installed in the printer. The standard communication interfaces are an RS-232 serial data port, a bi-directional parallel port, and a USB 2.0 port.



Note • RS-422 and RS-485 serial data ports are available through an adapter. A DB-25 cable and a USB 2.0 cable are also available.

The following illustration shows the location of the communication interfaces on the back of the printer. For more information about these interfaces, see [Data Ports on page 55](#).

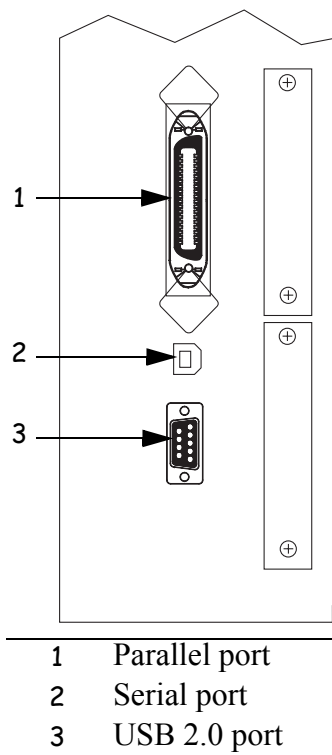

Other options for connecting your printer to a data source include the following:

- The optional BradyConnect[®] PrintServer II, which enables the printer to be connected to 10Base-T Ethernet networks.
- A wireless card socket option.
- The IBM[®] Twinax or IBM[®] Coax option for those applications that require them.

Data Cable Requirements

Data cables must be fully shielded and fitted with metal or metallized connector shells. Shielded cables and connectors are required to prevent radiation and reception of electrical noise.

To minimize electrical noise pickup in the cable:

- Keep data cables as short as possible.
- Do not bundle the data cables tightly with the power cords.
- Do not tie the data cables to power wire conduits.



Note • Brady printers comply with FCC Rules and Regulations, Part 15 for Class B Equipment using fully shielded, 6.5 ft (2 m) data cables. Use of unshielded cables may increase radiation above the Class B limits.



Note • RS-422 and RS-485 applications should use twisted shielded pairs as recommended in the TIA/EIA-485 Specification.

Types of Media

The printer can use media that is on rolls or in fan-folded stacks. The difference between media types is in whether the media is continuous or non-continuous.

We strongly recommend the use of Brady-brand supplies for continuous high-quality printing. A wide range of paper, polypropylene, polyester, and vinyl stock has been specifically engineered to enhance the printing capabilities of the printer and to ensure against premature printhead wear.



Note • Because print quality is affected by media and ribbon, printing speeds, and printer operating modes, it is very important to run tests for your applications.

Continuous Media

Continuous media is one uninterrupted length of material that allows the image to be printed anywhere on the label. The individual labels can be cut apart or stored in a roll for later use.

This illustration shows a sample of continuous media.



Non-Continuous Black Mark Media

Non-continuous black mark media has black marks printed on the back, which indicate the start and end of each label. This illustration shows a sample of non-continuous black mark media.

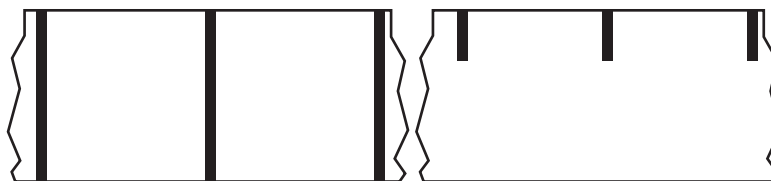

Non-Continuous Web Media

Non-continuous web media refers to individual labels that are separated by a gap, notch, or hole. When you look at the media, you can tell where one label ends and the next one begins.



Important • The life of the printhead may be reduced by the abrasion of exposed paper fibers when using perforated media.

This illustration shows samples of non-continuous web media.

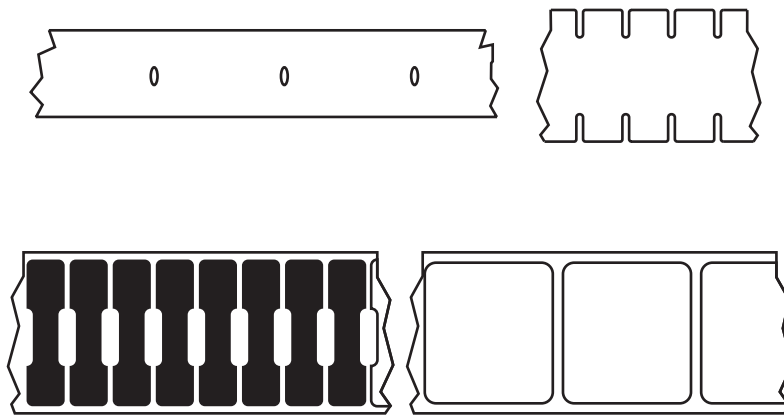



Ribbon

The media determines whether you need to use ribbon and determines the minimum width of the ribbon. Consider the following:

- **Thermal transfer** — ribbon needed.

The ribbon must be as wide as or wider than the media being used. If the ribbon is narrower than the media, areas of the printhead are unprotected and subject to premature wear.

- **Direct thermal transfer** — no ribbon needed.

When printing in direct thermal mode, ribbon is not used and should not be loaded in the printer.



CHAPTER 3

Printer Operation

If you have completed the tasks and resolved the issues in the checklist in *Before You Begin* on page 10, follow the instruction in this chapter to load and calibrate your printer and to print a configuration label.

Contents

Load the Printer	22
Load Roll Media	22
Load Fanfold Media	24
Load Ribbon	26
Remove Used Ribbon	30
Print a Configuration Label	31
Calibrate the Printer	33
Adjust Sensors	34
Media and Ribbon Sensor Calibration	34
Transmissive (Media) Sensors	36
Adjust the Printhead	39

Load the Printer

This section gives you a series of instructions to load labels and ribbon (if used). The instructions that follow are for a standard printer in Tear-Off Mode. To choose different printing modes, see *Print Modes* on page 41.



Caution • Be sure the printer is Off (O) if you have connected the power cable.

Load Roll Media

Roll media feeds through the printer from the media hanger or media supply spindle.

This illustration identifies the components of the printer that you need to be familiar with to load roll media.

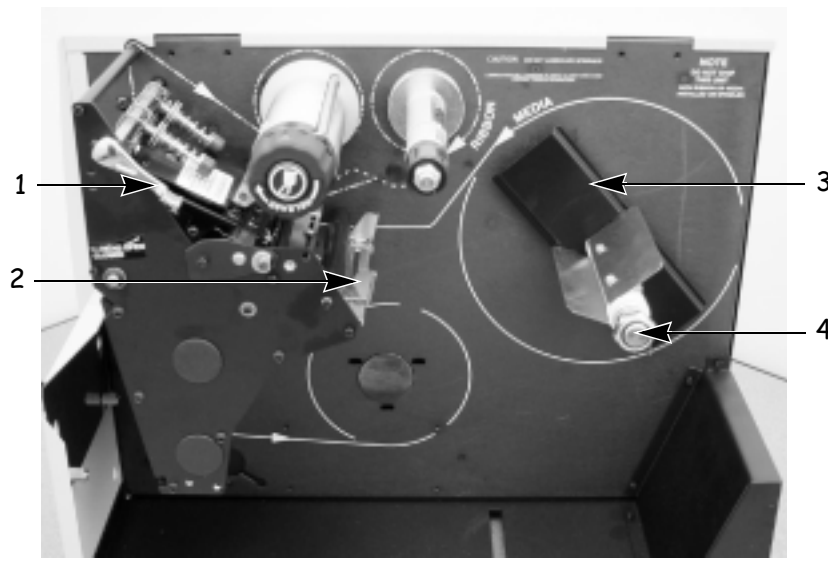

-
- | | |
|---|------------------------|
| 1 | Printhead lever |
| 2 | Media guide |
| 3 | Media back plate |
| 4 | Optional media spindle |
-

To load roll media, complete these steps:

1. Open the printhead.
2. Slide the media guide away from the printer frame. You might need to loosen the media guide screw.
3. Put the roll of media on the media hanger.
4. Push the label core toward the printer frame. The labels must be aligned with the label core.
5. Feed the media under the media guide roller and under the printhead.
6. Do you have the Cutter option?
 - **No** — continue with the next step.
 - **Yes** — feed the media through the cutter.



Caution • The cutter blade is sharp. Do not rub or touch the blade with your fingers.

7. Adjust the media supply guide so it is just touching, but does not restrict, the edge of the media. The labels should lie flat as shown in the illustration.

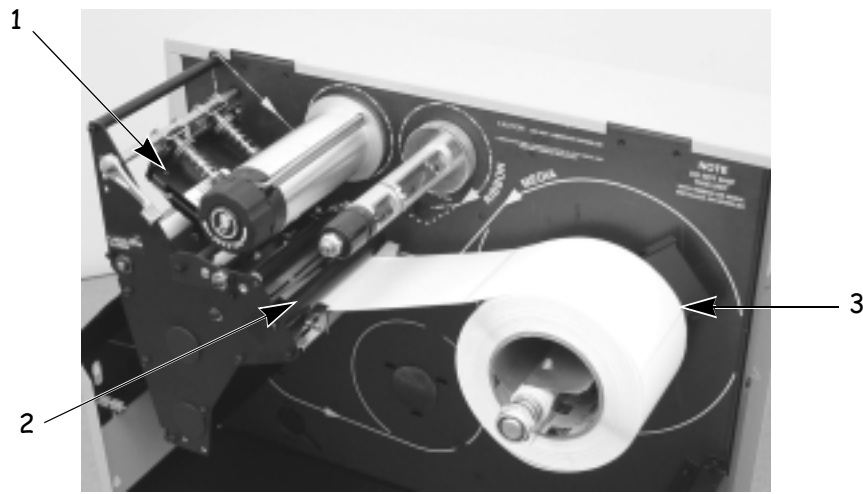

- | | |
|---|--------------------|
| 1 | Printhead |
| 2 | Media guide roller |
| 3 | Labels/media |

8. Are you using direct thermal labels?
 - **Yes** — close the printhead and go to *Print a Configuration Label* on page 31.
 - **No** — go to *Load Ribbon* on page 26.

Load Fanfold Media

Fanfold media feeds through either the bottom or rear access slot from outside the printer. The media hanger and media supply spindle are **not** used with fanfold media.

To load fanfold labels, complete these steps:

1. Slide the printhead lever to the Open position.
2. Slide the media guide as far from the printer frame as possible.
3. How do you want to feed the fanfold labels?
 - **From the bottom slot in the printer body.**
This illustration shows the printer with fanfold labels loaded through the bottom slot.

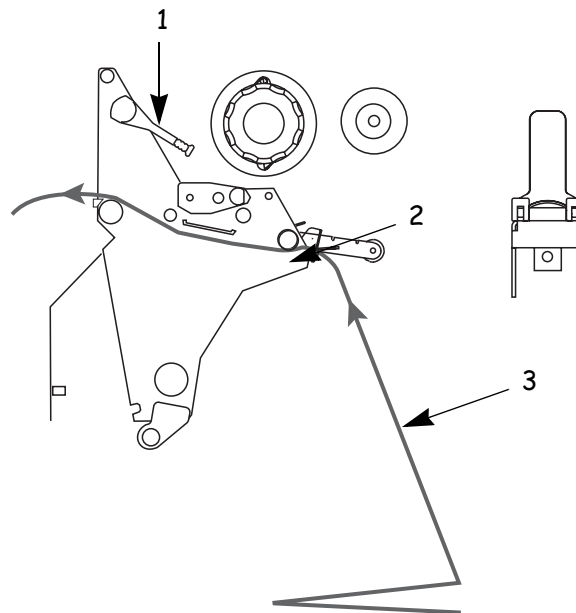

-
- | | |
|---|---|
| 1 | Printhead lever
(shown in the Open position) |
| 2 | Media guide |
| 3 | Fanfold labels |
-

- **From the rear slot in the printer body.**
This illustration shows the printer with fanfold labels loaded through the rear slot.

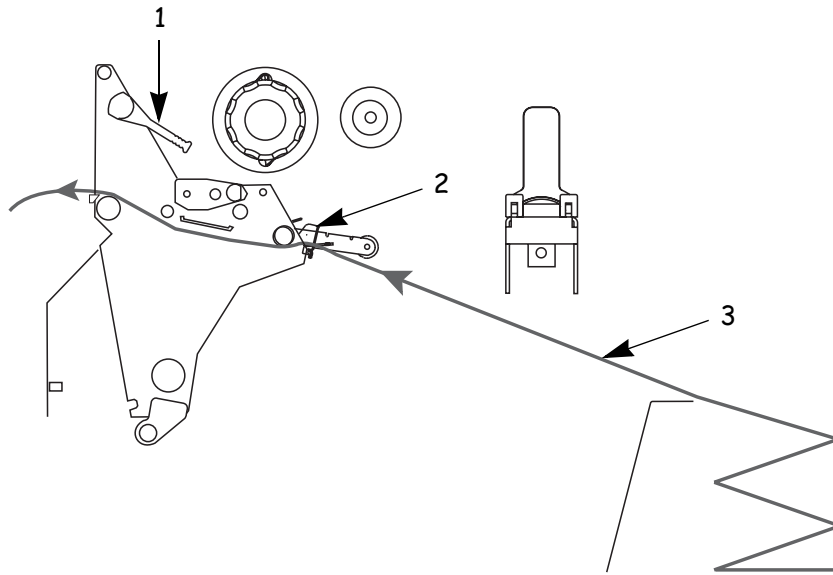

-
- | | |
|---|--|
| 1 | Printhead lever (shown in the Open position) |
| 2 | Media guide |
| 3 | Fanfold labels |
-

4. Do you have the Cutter option?
- **No** — continue with the next step.
 - **Yes** — feed the fanfold media through the cutter.



Caution • The cutter blade is sharp. Do not rub or touch the blade with your fingers.

5. Adjust the media guide so it just touches, but does not restrict, the edge of the labels. The labels should lie flat.
6. Are you using direct thermal labels?
- **Yes** — close the printhead and go to *Print a Configuration Label* on page 31.
 - **No** — go to *Load Ribbon* on page 26.

Load Ribbon

Before you load ribbon, make sure that the labels that you are using need ribbon. Only thermal transfer labels require ribbon. Do not load ribbon if the printer is to be used with direct thermal labels.

Caution • Use ribbon that is wider than the thermal transfer media. If the printhead is not protected by the ribbon, the resulting abrasion from the media may cause premature printhead wear.

A ribbon leader makes it easier to load and unload ribbon. Make a leader for your ribbon roll if it does not already have one.

To make a ribbon leader, complete these steps:

1. Unroll the ribbon about 6 in. (15 cm).

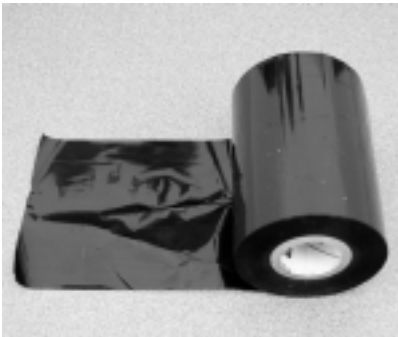

2. Tear off a strip of labels and backing about 6 in. (15 cm) long from the label roll.
3. Peel a label from the backing.
4. Overlap the ribbon and the backing with the ribbon on top, and use the label to tape them together. This serves as a ribbon leader.

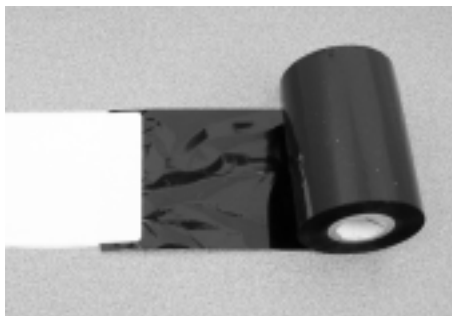

To load the ribbon, complete these steps:

1. Align the segments of the ribbon supply spindle as shown in the following illustration.

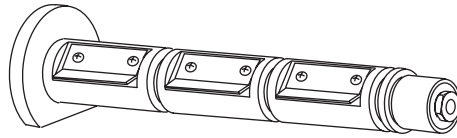

2. Place the roll of ribbon on the ribbon supply spindle, and push the core as far back as it can go. The following illustration shows the printer components that are mentioned in this procedure.

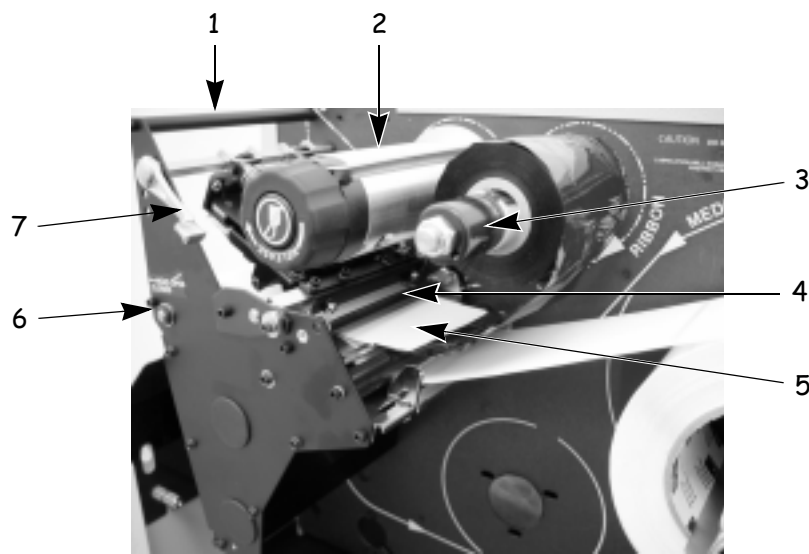

-
- | | |
|---|---|
| 1 | Top roller |
| 2 | Ribbon take-up spindle |
| 3 | Ribbon supply spindle |
| 4 | Ribbon guide roller |
| 5 | Ribbon leader attached to ribbon |
| 6 | Platen roller (not shown) |
| 7 | Printhead lever
(shown in the Open position) |
-

3. If the printhead is closed, open it using the printhead lever.
4. Thread the ribbon leader and attached ribbon under the ribbon guide roller, through the print mechanism, and past the platen roller.

 **Note** • For the BP THT 360X-Plus II, thread the leader first through the ribbon dancer roller assembly.

- 5.** Pull the ribbon leader over the printhead and above the top roller as shown in the following illustration.



1 Ribbon leader
2 Printhead

- 6.** Bring the ribbon leader and ribbon under the ribbon take-up spindle, and wrap them around the spindle. The following illustration shows the ribbon leader wrapped around the ribbon take-up spindle.

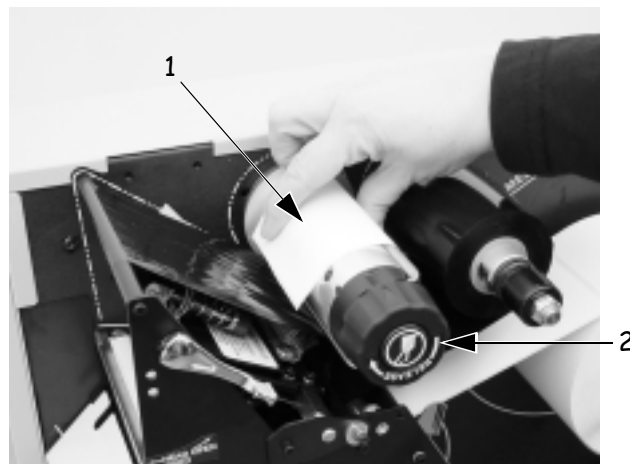

1 Ribbon leader
2 Ribbon take-up spindle

- 7.** Turn the spindle counterclockwise until the ribbon stays on the spindle.

8. Close the printhead.

The following illustration shows how your printer should look with the media and ribbon loaded.

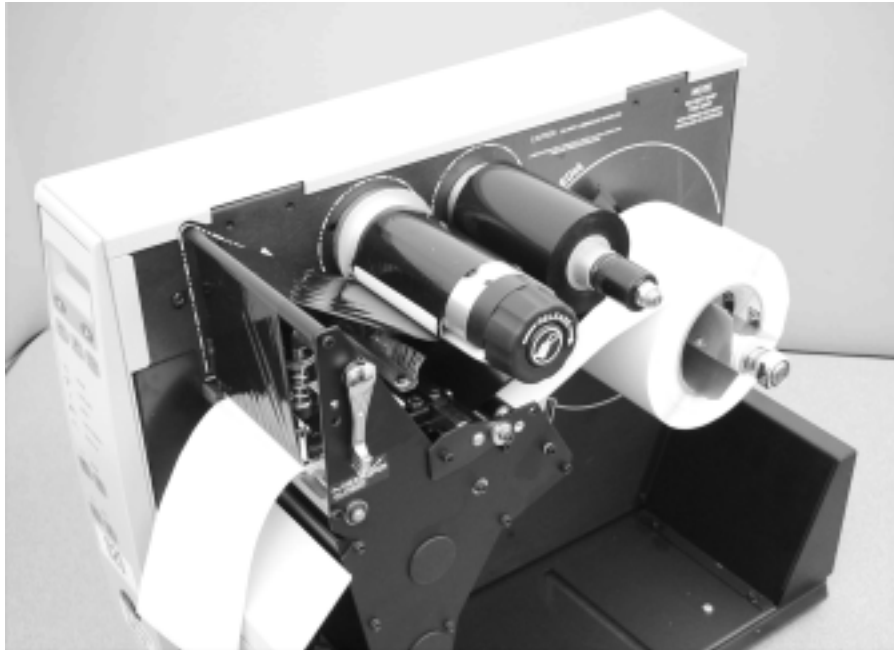

9. To remove the ribbon, refer to *Remove Used Ribbon* on [page 30](#).

Remove Used Ribbon

When the ribbon has run out or must be changed, remove the used ribbon from the take-up spindle. This illustration shows the ribbon take-up spindle.

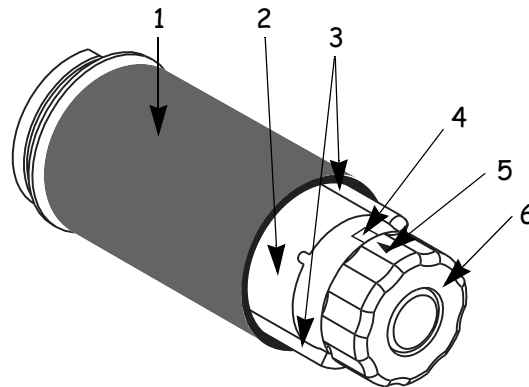

1	Used ribbon
2	Ribbon take-up spindle
3	Ribbon release bars
4	Notch in ribbon take-up spindle
5	Arrow on ribbon take-up spindle
6	Ribbon release knob

To remove used ribbon, complete these steps:

1. Open the printhead.
2. Has the ribbon run out?
 - **Yes** — continue with the next step.
 - **No** — tear or cut the ribbon as close to the ribbon take-up spindle as possible.

Caution • Do not cut through the ribbon that is on the take-up spindle because you may damage the spindle. Use the release knob to slide the ribbon off of the spindle.
3. While holding the ribbon take-up spindle, turn the ribbon release knob clockwise until it stops. This causes the ribbon release bars to pivot down, easing the spindle's grip on the used ribbon.
4. Slide the used ribbon off of the ribbon take-up spindle.
5. Align the arrow on the ribbon take-up spindle knob with the notch in the ribbon take-up spindle.
6. To load new ribbon, see *Load Ribbon* on page 26.

Print a Configuration Label

When you have loaded the media and ribbon (if necessary), print a configuration label to use as a record of your printer settings. Keep the configuration label for baseline information on your printer when troubleshooting printing problems.



Caution • For personal and equipment safety, always use an approved three-conductor power cord specific to the region or country intended for installation. This cord must use an IEC 320 female connector and the appropriate region-specific three-conductor grounded plug configuration.

To print a configuration label, complete these steps:

1. Connect the power cord to the power connection on the back of the printer.
2. To confirm the power connection, turn the printer On (I).

The printer performs the power-up self test (POST). When the test is complete, **PRINTER READY** displays on the front panel LCD.

3. Does the front panel LCD display **PRINTER READY**?
 - **Yes** — continue with the next step.
 - **No** — go to *Troubleshooting on page 111*.
4. Turn the printer Off (O).
5. Press and hold **CANCEL** while turning the printer On (I).
6. Release **CANCEL** when the **DATA** light turns off (approximately five seconds).

The configuration label prints. A sample label, which may look different than yours, is shown below.

PRINTER CONFIGURATION	
Zebra Technologies	
ZTC 50x111 Plus-300dpi	
04.0	DARKNESS
2.125	PRINT SPEED
+000	TEAR OFF
TEAR OFF	PRINT MODE
NON-CONTINUOUS	MEDIA TYPE
48H	SENSOR TYPE
THERMAL-TRANS	PRINT METHOD
066 06/12 RH	PRINT WIDTH
2032	LABEL LENGTH
20.01H 900PH	MAXIMUM LENGTH
MEDIA DISABLED	EARLY WARNING
PRINT OFF	EARLY WARNING
NOT CONNECTED	USB COMM.
PARALLEL	PARALLEL COMM.
RS232	SERIAL COMM.
8E00	DATA BITS
8 BITS	PARITY
NONE	HOST HANDSHAKE
NON-MSR	PROTOCOL
NONE	PROTOCOL
000	NETWORK ID
NORMAL MODE	COMMUNICATIONS
<+> ZEN	CONTROL PREFIX
<+> SCH	FORMAT PREFIX
<+> SCH	DELIMITER CHAR
ZPL II	ZPL MODE
CALIBRATION	MEDIA POWER UP
CALIBRATION	HEAD CLOSE
DEFAULT	BARCODE
+000	LABEL TOP
+0000	LEFT POSITION
0000	HEAD TEXT COUNT
0500	HEAD RESISTOR
OFF	VERIFIER PORT
OFF	APPLICATOR PORT
PULSE MODE	START PRINT SIG
FEED MODE	RESYNCH MODE
DISABLED	REPRINT MODE
047	MEDIA S.
079	MEDIA S.
092	REASON S.
050	MARK S.
000	MARK TED S.
000	MEDIA LED
000	ATTACH LED
000	MARK LED
+10	LED ADJUST
0P5MFM	MODES ENABLED
	MODES DISABLED
1024 12/PH FULL	RESOLUTION
048.X.X CP	FIRMWARE
V12.0.0.ZI	HARDWARE ID
CUSTOMIZED	CONFIGURATION
3228B	RAM
2048	ONBOARD FLASH
NONE	FORMAT CONVERT
007 PAPER SUPPLY	POST INTERFACE
004 DISPLAY	PSD INTERFACE
	TWINK-COMM ID
F4 VERSION	IDLE DISPLAY
00/00/00	RTC DATE
18:18	RTC TIME
DYNAMIC	IP RESOLUTION
ALL	IP PROTOCOL
010.003.004.005	IP ADDRESS
255.255.255.000	SUBNET MASK
010.003.004.001	DEFAULT GATEWAY

7. Did the label print?

- **Yes**, a configuration label printed. Connect the printer to your data source. Communication can be handled in many different ways. More information about the standard interfaces is available in *Standard Ports* on page 56.
- **No**, a label did not print. Sensors out of position is a common cause of printing problems. Refer to *Adjust Sensors* on page 34. For additional assistance, refer to *Troubleshooting* on page 111.

Calibrate the Printer

There are five different ways that the printer can be calibrated. You may calibrate the printer as needed.

- **Auto-calibration** occurs when the printer feeds media after the printhead is closed and when the printer is first turned on (see *Media Power Up* on page 89 and *Head Close* on page 89 for options). The printer automatically sets the value it detects for the spaces between labels. This type of calibration also happens as part of both the sensor profile and media and ribbon sensor calibration procedures.
- **Long Calibration**, which you select by pressing PAUSE then CALIBRATE, calibrates the printer for media length, media type (continuous or non-continuous), and print mode (thermal or direct thermal transfer) and updates the sensor values.
- **Short Calibration**, which you select by pressing just CALIBRATE, uses current sensor values rather than detecting the spaces between labels and resetting the sensors. This calibration sequence uses fewer labels than the long calibration sequence, but it is less reliable because the values that are stored in the sensors could be incorrect.



Note • If you press CALIBRATE and nothing happens, you may need to upgrade your firmware. Print a configuration label to see which version of firmware that is installed on your printer. To upgrade your firmware or to check if you have the latest version, go to

<http://www.bradyid.com/brady/isdwebv2.nsf/webpages/downloads>.

- **Sensor Profile Calibration**, which you select through the front panel, auto-calibrates the printer and prints a media sensor profile. See *Sensor Profile* on page 83 for instructions.
- **Media and Ribbon Sensor Sensitivity Calibration**, which you select through the front panel, resets the sensitivity of the sensors to detect correctly the media and ribbon that you are using. See *Media and Ribbon Sensor Calibration* on page 34 for instructions. If you change the type of ribbon and/or media, you might need to reset the sensitivity of the media and ribbon sensors. When the sensors are at their new sensitivity, the printer performs an auto-calibration.

Adjust Sensors

This section describes how to adjust and calibrate sensors.

Media and Ribbon Sensor Calibration

Media and ribbon sensor calibration is one of the most common adjustments to the printer settings. This procedure is performed through the front panel.

Indications that the sensitivity may need to be reset are:

- The CHECK RIBBON light is on even though the ribbon is properly installed.
- Non-continuous labels are being treated as continuous labels.



Note • Before you begin the calibration procedure, make sure that the maximum length is set to a value 1 in. (25.4 mm) greater than the length of the labels that you are using. If the maximum length is set to a lower value, the calibration process assumes that continuous media is in the printer.



Important • This procedure must be followed exactly as presented. All of the steps must be performed even if only one of the sensors requires adjustment. You may press the left oval at any step in this procedure to cancel the procedure.

To adjust the sensitivity of media and ribbon sensors, complete these steps:

1. From the front panel, press the right oval to start the calibration procedure.
The **LOAD BACKING** prompt displays.
2. Open the printhead.
3. Remove approximately 8 in. (203 mm) of labels from the media backing, and pull the media into the printer so that only the backing is between the media sensors.
4. Leave the printhead open.
5. Press the right oval to continue.
The **REMOVE RIBBON** prompt displays.
6. Remove the ribbon.
7. Close the printhead.

8. Press the right oval to continue.

The message CALIBRATING PLEASE WAIT displays.

The printer adjusts the scale (gain) of the signals that it receives from the media and ribbon sensors. On the sensor profile, this essentially corresponds to moving the peak of the graph up or down to optimize the readings for your application (for more information, see *Sensor Profile* on page 83).

When calibration is complete, RELOAD ALL displays.

9. Open the printhead and pull the media forward until a label is positioned under the media sensor.
10. Reload the ribbon back into to its proper position.
11. Close the printhead.
12. Press the right oval to continue.

The printer does a calibration equivalent to pressing CALIBRATE; during this process, the printer determines the label length. To see the new readings on the new scale, print a sensor profile.

Transmissive (Media) Sensors

The transmissive sensor consists of two sections: a light source (the lower media sensor) and a light sensor (the upper media sensor). The media passes between the two. The upper media sensor can be positioned along the inside half of the media (the side closest to the back of the printer) or the outside half of the media (the side farthest from the back of the printer).

Adjust these sensors only when the printer cannot detect the top of the label. The front panel LCD displays **ERROR CONDITION PAPER OUT**, even though there are labels loaded in the printer.

To adjust the upper media sensor for the inside half of the media, complete these steps:

1. Remove the ribbon (if ribbon is used).
2. Locate the upper media sensor as shown in the following illustration. The upper media sensor eye is directly below the adjustment screw head.

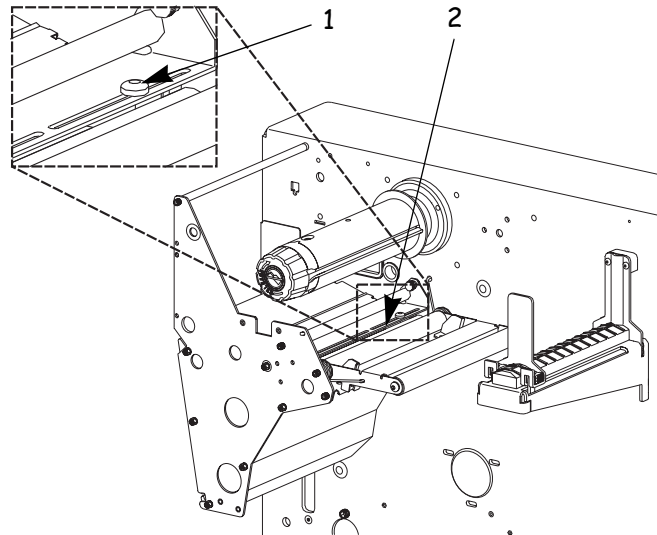

-
- | | |
|---|-------------------------------------|
| 1 | Upper media sensor adjustment screw |
| 2 | Upper media sensor |
-

3. Slightly loosen the upper media sensor adjustment screw using a Phillips-head screwdriver.
4. Using the tip of the screwdriver, slide the upper sensor along the slot to the desired position (for non-continuous media with a notch or hole in the media, the sensor must be directly above the notch or hole).
5. Tighten the adjustment screw to secure the upper media sensor.



To adjust the upper media sensor for the outside half of the media:

1. Remove the ribbon (if ribbon is used).
2. Locate the upper media sensor. The upper media sensor eye is directly below the adjustment screw head.
3. Remove the upper media sensor adjustment screw using a Phillips-head screwdriver.
4. Lift the upper media sensor assembly from the slot, and move it and the wire cover to the outside slot. Carefully pull the wires through the cable tie. You may need to set aside the sensor wire cover if the adjustment is too far to the outside.
5. Replace and slightly tighten the adjustment screw.
6. Slide the upper media sensor along the slot to the desired position (for non-continuous media with a notch or hole in the media, the sensor must be directly above the notch or hole).
7. Tighten the adjustment screw.
8. Make sure that the wires are routed back into the groove of the media sensor bracket.

To adjust the lower media sensor, complete these steps:

1. Locate the lower media sensor assembly under the rear roller. (The sensor is a spring clip holding a circuit board.)

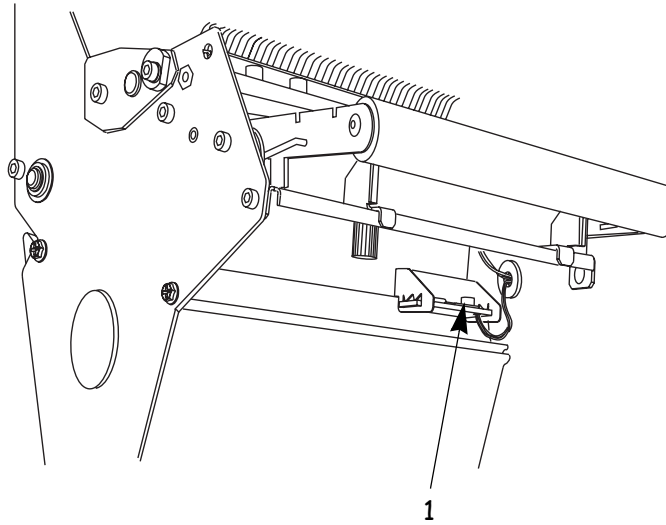

1 Lower media sensor

2. Slide the sensor until the two brass-colored infrared emitters are under the upper media sensor. Gently pull wires out as needed (wires should have a little slack).
3. If you move the sensor inward and a large loop of wire develops, remove the electronics cover from the side of the printer, and gently pull the wires through. Clamp the wires so that they do not rub any drive belts.

Adjust the Printhead



Important • Print quality depends on the labels and ribbon used as well as the toggle pressure. Make sure your labels and ribbon are right for your application.

- **Direct thermal labels** do not need ribbon.
- **Thermal transfer labels** need thermal transfer ribbon.

Printhead pressure and the darkness setting affect print quality. If the darkness setting is too high for the labels and ribbon being used, it causes premature printhead wear. If the toggle pressure is not even, labels and ribbon may slip.

Toggle adjustment may be needed if printing is too light on one side or if thick labels are used. Make sure that the toggles are positioned properly.

The toggles should be positioned so they provide even pressure on the labels. The toggles are positioned by sliding them to the desired location. If the labels are too narrow to fit both toggles, position one toggle over the center of the labels and decrease the pressure on the unused toggle.

If positioning the toggles properly does not solve the problem, adjust printhead pressure. Printhead life can be maximized by using the lowest pressure that produces the desired print quality.



Caution • Observe proper electrostatic safety precautions when handling any static-sensitive components such as circuit boards and printheads.

To adjust printhead pressure, complete these steps:

1. Print some labels at 2.4 in. (61 mm) per second by running the *PAUSE Self Test* on page 125.
2. While printing labels, use the front panel controls to lower the darkness setting until the labels are printing gray instead of black.
3. Loosen the locking nuts at the top of the toggle assemblies.

Printer Operation
Adjust the Printhead

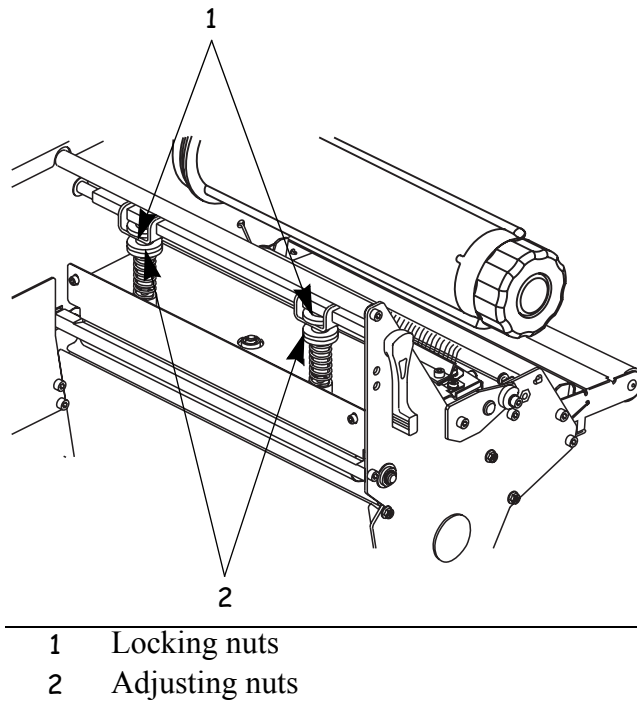

4. Some media types require higher pressure to print well. For these media types, increase or decrease pressure using the adjusting nuts until the left and right edges of the printed area are equally dark.
5. Increase the darkness level using the front panel controls until the printing is clear.
6. Tighten the locking nuts.

CHAPTER 4

Print Modes

This chapter describes the available print modes.

Contents

Select a Print Mode	42
Tear-Off Mode	42
Peel-Off Mode	43
Cutter Mode.	45
Rewind Mode	47
Rewind Mode with Cutter Option.	50
Remove Backing from Rewind Spindle	53

Select a Print Mode

The options on your printer may let you set up additional print modes. Use the front panel controls to set up the printer to the print mode that you wish to use.

The following are the available print mode selections:

- Tear-off
- Peel-off
- Cutter
- Rewind
- Applicator (used only if a machine will apply printed labels to something)

To select a print mode, complete these steps:

1. From the front panel, press SETUP/EXIT.
2. Press NEXT/SAVE until the LCD reads PRINT MODE.
3. Use the right or left oval to scroll through the choices. Be sure to select a print mode that your hardware supports—some of the selections displayed are for optional printer features.
4. To save your selection, press SETUP/EXIT.

Tear-Off Mode

See *Load the Printer* on [page 22](#) to set up labels in Tear-Off Mode.

Peel-Off Mode

Peel-Off Mode advances one label at a time. The printer does not print another label until the first label is removed. The TAKE LABEL light flashes until the label is removed. The backing is wound on the rewind spindle, but the rewind plate is not used.

This illustration shows the printer loaded with labels in Peel-Off Mode.

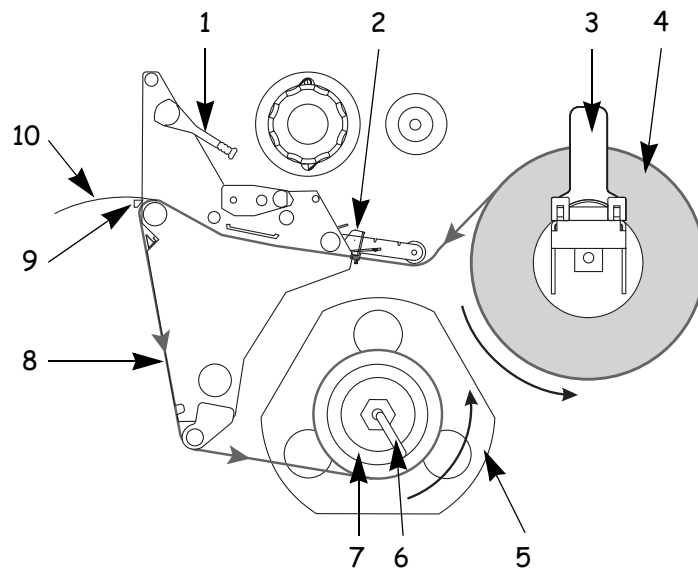

-
- | | |
|----|--------------------|
| 1 | Printhead lever |
| 2 | Media guide |
| 3 | Media supply guide |
| 4 | Media |
| 5 | Guide plate |
| 6 | Spindle hook |
| 7 | Rewind spindle |
| 8 | Label backing |
| 9 | Tear-off bar |
| 10 | Printed label |
-

To set up the printer in Peel-Off Mode, complete these steps:

1. Remove the rewind plate (if installed) from the front of the printer. Store it on the two mounting screws on the inside of the front panel.
2. From the front panel, select Peel-Off Mode.
3. Open the printhead.
4. Slide the media guide and media supply guide as far from the printer frame as possible.
5. Flip down the media supply guide.
6. Put the roll of media on the media hanger.
7. Push the label core toward the printer frame. The labels must be aligned with the label core.
8. Feed the media under the media guide roller and under the printhead.
9. Adjust the media supply guide so it is just touching the edge of the media.
10. When loading labels, allow approximately 36 in. (915 mm) of labels to extend past the tear-off/peel-off bar. Remove all labels from this portion to create a leader.
11. Remove the hook from the rewind spindle. If you are using a core, slide it onto the rewind spindle until it is flush against the guide plate.
12. Wind the label backing around either the 3 in. (76 mm) core or the rewind spindle and reinstall the hook.
13. Flip up the media supply guide. Slide in the media guide and media supply guide so they just touch, the edge of the labels. The labels should lie flat.
14. Before closing the printhead, make sure that:
 - The labels are positioned against the inside guides.
 - The labels are taut and parallel with the pathway when wound onto the rewind spindle or core.
15. Close the printhead.

The backing winds on the rewind spindle or core.

Cutter Mode

A cutter is a rotating knife with a self-sharpening blade that is attached to the front of the printer. The cutter is used to cut individual labels as they are printed. See www.bradyid.com for more information about the cutter option.

This illustration shows the printer loaded with labels in Cutter Mode.

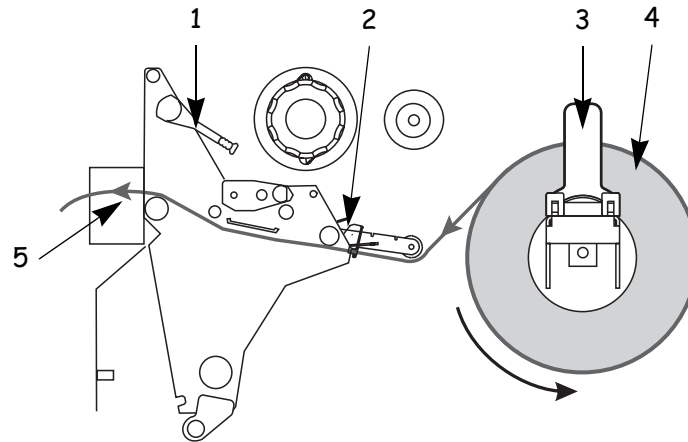

-
- | | |
|---|--------------------|
| 1 | Printhead lever |
| 2 | Media guide |
| 3 | Media supply guide |
| 4 | Media |
| 5 | Cutter |
-

To set up the printer in Cutter Mode, complete these steps:

1. Turn the printer On (I).
2. From the front panel, select Cutter Mode.
3. Open the printhead.
4. Slide the media guide and media supply guide as far from the printer frame as possible.
5. Flip down the media supply guide.
6. Put the roll of media on the media hanger.
7. Push the label core toward the printer frame. The labels must be aligned with the label core.
8. Feed the media under the media guide roller and under the printhead.

Print Modes

Select a Print Mode



Caution • The cutter blade is sharp. Do not rub or touch the blade with your fingers.

9. Feed the labels through the cutter mechanism.
10. Flip up the media supply guide.
11. Slide in the media guide and media supply guide so they just touch, but do not restrict, the edge of the roll.
12. Before closing the printhead, make sure that:
 - The labels are positioned against the inside guides.
 - The labels are taut and parallel with the pathway when wound onto the rewind spindle or core.
13. Close the printhead.

Rewind Mode

Rewind Mode allows the media to be wound on a core after printing.

The following illustration shows the printer loaded with labels in Rewind Mode.

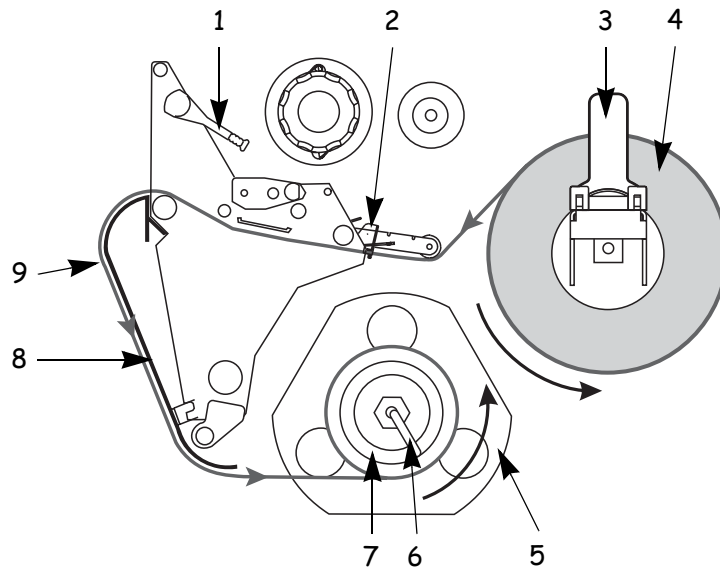

-
- | | |
|---|--------------------|
| 1 | Printhead lever |
| 2 | Media guide |
| 3 | Media supply guide |
| 4 | Labels |
| 5 | Guide plate |
| 6 | Spindle hook |
| 7 | Rewind spindle |
| 8 | Rewind plate |
| 9 | Printed labels |
-

To install the rewind plate, complete these steps:

1. Remove the rewind plate from its storage location inside the printer.
2. Position the rewind plate so that the lip on the attached hook plate points down.
3. Insert the hook plate lip 1/2 in. (13 mm) into the lower slot in the side plate.
4. Align the upper end of the rewind plate with the matching slot in the side plate.
5. Slide in the rewind plate until it stops against the printer's main frame.

This illustration shows the rewind plate and where it hooks to the printer.

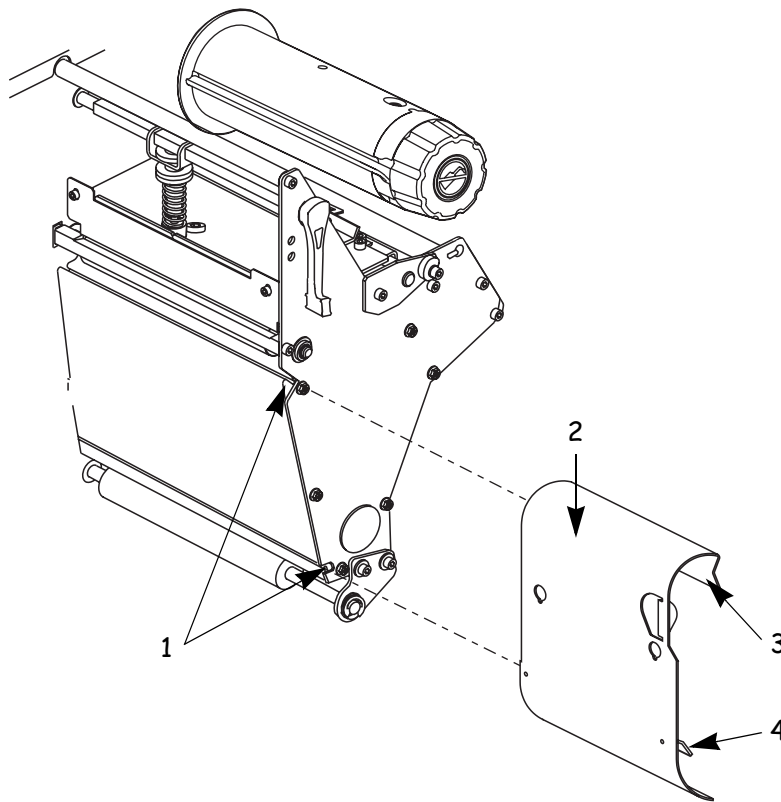

-
- | | |
|---|-----------------------|
| 1 | Slots |
| 2 | Rewind plate |
| 3 | Lip |
| 4 | Adjustable hook plate |
-



To set up the printer in Rewind Mode, complete these steps:

- 1.** If you have not already done so, install the rewind plate.
- 2.** From the front panel, select Rewind Mode.
- 3.** Open the printhead.
- 4.** Slide the media guide and media supply guide as far from the printer frame as possible. Flip down the media supply guide.
- 5.** Put the roll of media on the media hanger.
- 6.** Push the label core toward the printer frame. The labels must be aligned with the label core.
- 7.** Feed the media under the media guide roller and under the printhead.
- 8.** Adjust the media supply guide so it is just touching the edge of the media.
- 9.** When loading labels, allow approximately 36 in. (915 mm) of labels to extend past the printhead. Remove all labels from this portion to create a leader.
- 10.** Remove the hook from the rewind spindle. If you are using a core, slide it onto the rewind spindle until it is flush against the guide plate.
- 11.** Wind the label backing around either the 3 in. (76 mm) core or the rewind spindle. Reinstall the hook.
- 12.** Flip up the media supply guide. Slide in the media guide and media supply guide so they just touch the edge of the labels. The labels should lie flat.
- 13.** Before closing the printhead, make sure that:
 - The labels are positioned against the inside guides.
 - The labels are taut and parallel to the pathway when wound onto the rewind spindle or core.
- 14.** Close the printhead.

The labels wind on the rewind spindle or core.

Rewind Mode with Cutter Option

Printers with the cutter option can use the Rewind Mode to print and save a roll of labels. See www.bradyid.com for more information about the cutter option.



Note • Rewind Mode cannot be used with the cutter option on the BP THT 300X-Plus II and 600X-Plus II.

This illustration shows the printer loaded with labels in Rewind Mode with the cutter option.

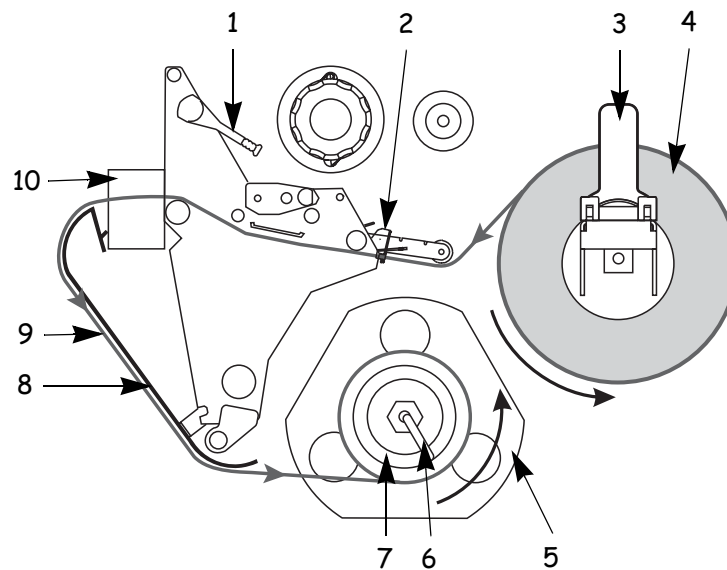

-
- | | |
|----|--------------------|
| 1 | Printhead lever |
| 2 | Media guide |
| 3 | Media supply guide |
| 4 | Labels |
| 5 | Rewind spindle |
| 6 | Guide plate |
| 7 | Spindle hook |
| 8 | Rewind plate |
| 9 | Printed label |
| 10 | Cutter |
-

To set up the Rewind Mode for printers with the cutter option, complete these steps:

1. Turn the printer On (I).
The printer feeds out and cuts one label.
2. From the front panel, select Rewind Mode.
3. Remove the rewind plate from its storage location in front of the print mechanism inside the media compartment.
4. Invert the rewind plate so that the lip on the attached hook plate points down.
5. Insert the hook plate lip 1/2 in. (13 mm) into the lower opening in the side plate. Slide in the rewind plate until it stops against the printer's main frame.
6. Insert the two small tabs on the rewind plate into the corresponding slots in the cutter support bracket. (The rewind plate should spring into the proper position.)
7. Open the printhead.
8. Slide the media guide and media supply guide as far from the printer frame as possible.
9. Flip down the media supply guide.
10. Put the roll of media on the media hanger.
11. Push the label core toward the printer frame. The labels must be aligned with the label core.
12. Feed the media under the media guide roller and under the printhead.



Caution • The cutter blade is sharp. Do not rub or touch the blade with your fingers.

13. Feed the labels through the cutter mechanism.
14. When loading labels, allow approximately 36 in. (915 mm) of labels to extend past the printhead. Remove all labels from this portion to create a leader.
15. Adjust the media supply guide so it is just touching the edge of the media.
16. Remove the hook from the rewind spindle.
17. If you are using a core, slide it onto the rewind spindle until it is flush against the guide plate.
18. Wind the label backing around either the 3 in. (76 mm) core or the rewind spindle.
19. Reinstall the hook.
20. Flip up the media supply guide.

 **Print Modes**

Select a Print Mode

- 21.** Slide in the media guide and media supply guide so they just touch, but do not restrict, the edge of the roll.
- 22.** Before closing the printhead, make sure that:
 - The labels are positioned against the inside guides.
 - The labels are taut and parallel with the pathway when wound onto the rewind spindle or core.
- 23.** Close the printhead.

The labels wind on the rewind spindle or core.

Remove Backing from Rewind Spindle

Rewind Mode and Peel-Off Mode use the rewind spindle. The label backing must be removed every time you change labels for the printer to work correctly.



Important • It is **not** necessary to turn off the power to remove backing from the rewind spindle. If power is turned off, all label formats and images, as well as any temporarily saved parameter settings stored in the printer's internal memory, are lost. When power is turned back on, these items must be reloaded.

To remove label backing from the rewind spindle, complete these steps:

1. Have the labels run out?
 - **Yes** — continue with the next step.
 - **No** — unwind approximately 36 in. (915 mm) of backing from the rewind spindle. Cut or tear it off at the spindle.
2. Pull out the spindle hook.
3. Slide the backing off of the rewind spindle and discard.
4. Replace the spindle hook.



Print Modes

Remove Backing from Rewind Spindle



CHAPTER 5

Data Ports

This chapter describes the standard communication ports on the printer.

Contents

Standard Ports.	56
Parallel Port.	56
Serial Port	58
USB 2.0 Port	64

Standard Ports

The different ports available to connect the printer to your computer or network include:

- Parallel
- Serial RS-232
- USB

Parallel Port

When communicating via the parallel port, the values selected must be the same as those used by the host equipment connected to the printer. Port selection for status information is determined by the channel sending the request. The parallel port can be set for bidirectional or unidirectional communication. The default setting is bidirectional.

A standard 36-pin parallel connector (as shown below) is available on the back of the printer for connection to the data source.

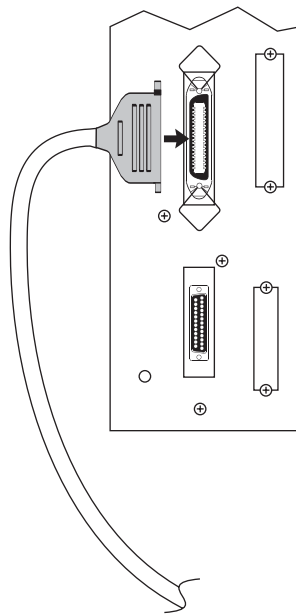

The following table shows the pin configuration and function of a standard computer-to-printer parallel cable.

36-Pin Connectors	Description
1	nStrobe/HostClk
2–9	Data Bits 1–8
10	nACK/PtrClk
11	Busy/PtrBusy
12	PError/ACKDataReq
13	Select/Xflag
14	nAutoFd/HostBusy
15	Not used
16, 17	Ground
18	+5 V at 750 mA The maximum current draw may be limited by option configuration.
19–30	Ground
31	ninit
32	nFault/NDataAvail
33, 34	Not used
35	+5 V through a 1.8 K Ω Resistor
36	NSelectin/1284 active

Serial Port

To communicate using the serial data port of the printer, you must choose the number of data and stop bits, parity, and handshaking. Parity applies only to data transmitted by the printer because the parity of received data is ignored.

The values selected must be the same as those used by the host equipment connected to the printer. Default settings are 9600 baud, 8 data bits, 1 stop bit, no parity, and XON/XOFF.

Connect the serial data cable to the female DB-9 connector (shown below) on the back panel of the printer.

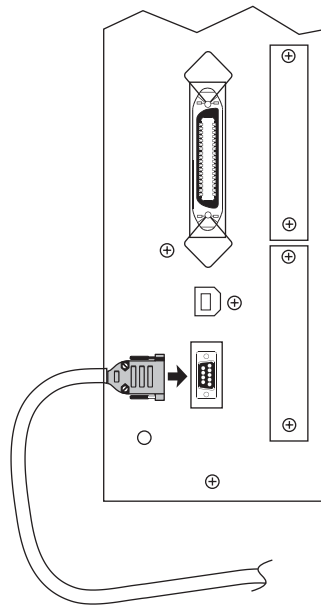

Use a DB-9 to DB-25 interface module for all RS-232 connections through a DB-25 cable. An interface module is required for RS-422/RS-485 interface support (see *RS-422/RS-485 Interconnections* on page 63).



Note • For all RS-232 input and output signals, the printer follows the specifications of the Electronics Industries Association (EIA) RS-232 and the Consultative Committee for International Telegraph and Telephone (CCITT) V.24.

Serial Pin Configuration

The table below shows the pin configuration and function of the rear panel serial data connector on the printer.

Pin No.	Name	Description
1	—	Not connected
2	RXD	Receive data—data input to printer
3	TXD	Transmit data—data output from printer
4	DTR	Data terminal ready—output from printer
5	SG	Signal ground
6	DSR	Data set ready—input to printer
7	RTS	Request to send—output from printer
8	CTS	Clear to send—input to printer
9	+5 VDC	+5 VDC signal output



Note • This pin is also available as a +5 VDC power source at 750 mA. The maximum current draw may be limited by option configuration. To enable this capability, a jumper on the printer's main logic board needs to be installed on JP1, pins 2 and 3.

RS-232 Interface Connections

Direct Connection to a Computer

The printer is configured as Data Terminal Equipment (DTE).



Note • The cable used to connect the printer to a computer must be a **null modem** (crossover) cable. To connect the printer to any other DTE devices, use a null modem cable.

This illustration shows the internal connections of the printer's RS-232 connector.

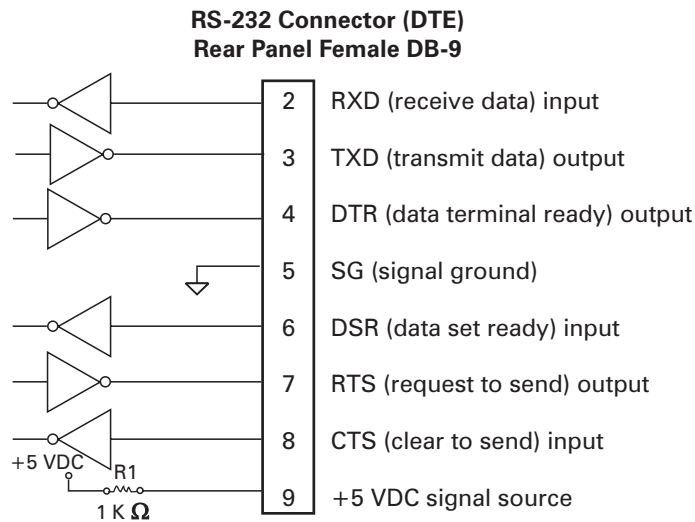

NOTE: Pin 1 is unused and unterminated.



Note • Pin 9 is also available as a +5 VDC power source at 750 mA. The maximum current draw may be limited by option configuration. To enable this capability, a jumper on the printer's main logic board needs to be installed on JP1, pins 2 and 3.

DB-9 to DB-25 Connections

An interface adapter is required to connect the printer's DB-9 interface to a DB-25 connector. A generic DB-25 adapter CAN be used, although the +5 VDC signal source would not be passed through the adapter.

This illustration shows the connections required for the DB-9 to DB-25 interface.

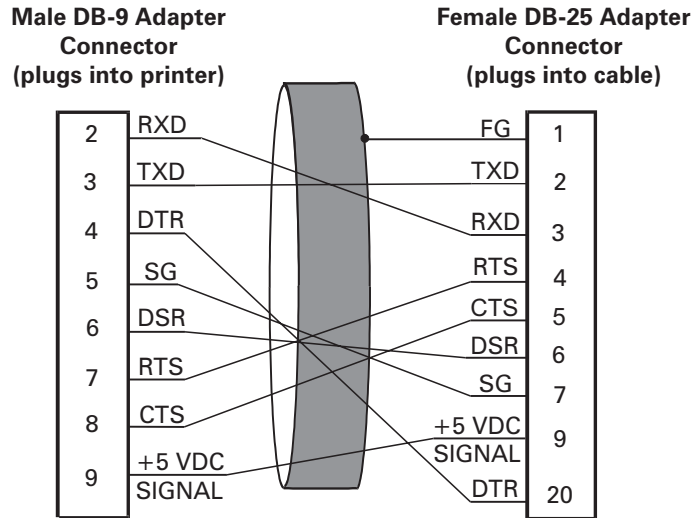

NOTE: Pin 1 of DB-9 connector is unused and unterminated.

Modem Connection

When the printer is connected via its RS-232 interface to Data Communication Equipment (DCE) such as a modem, use a standard RS-232 (straight-through) interface cable.

This illustration shows the connections required for this cable.

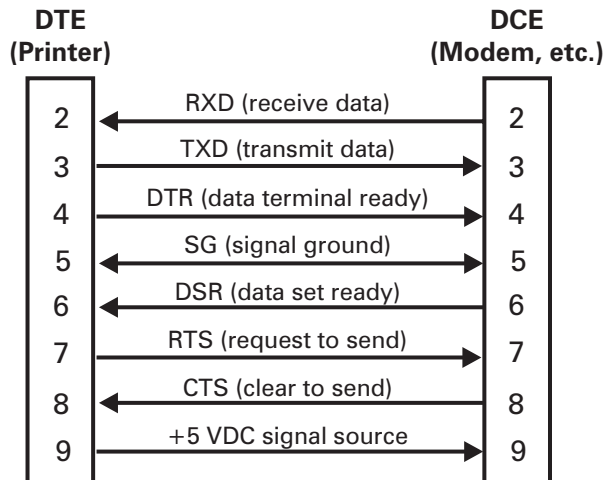

NOTE: Pin 1 is unused and unterminated at the printer.

RS-422/RS-485 Interconnections



Caution • A qualified service technician must install a jumper on the printer's main logic board at JP1, pins 2 and 3, for the RS-422/RS-485 interface adapter to function properly.

An interface adapter is required to connect the printer's RS-232 DB-9 interface to a host computer through an RS-422 or RS-485 interface. A generic DB-25 adapter can be used.

This illustration shows the cable wiring for interconnecting the DB-9 to the interface adapter's DB-25 female connector.

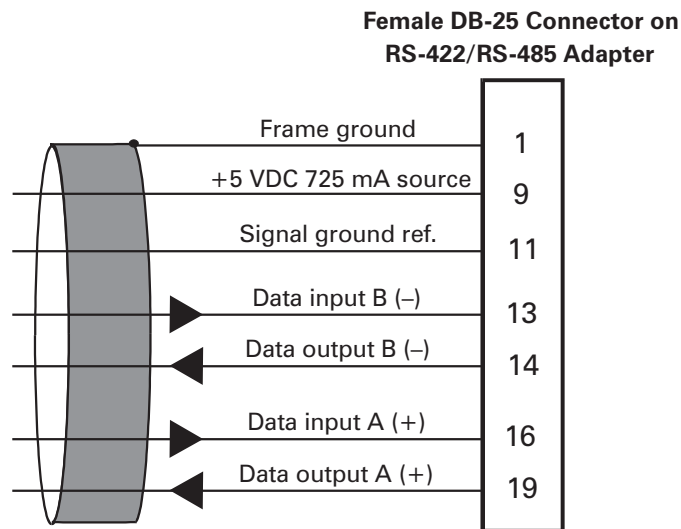

NOTE: Pins 2-8, 10, 12, 15, 17, 18, and 20-25 are unused and unterminated.

USB 2.0 Port

A USB 2.0 port (which is USB 1.1 and 1.0 compatible) is available to connect your printer to the host equipment. The industry-standard USB cable has an A-male connector on one end and a B-male connector on the other end as shown in the following illustration.

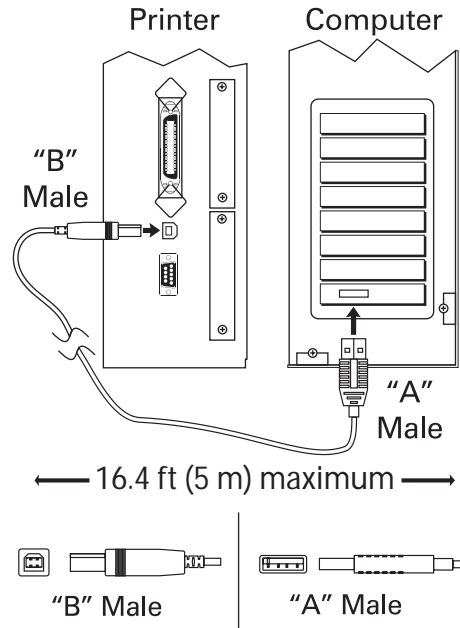

Note • Use a USB 2.0-certified compliant cable no longer than 16.4 ft (5 m) long.

CHAPTER 6

Memory Cards

This chapter describes the optional cards that can be used with the printer and gives instructions for installation.

Contents

PCMCIA Card	66
CompactFlash Card	68

PCMCIA Card

A Type 1- or Type II-compliant PCMCIA card holds extra memory or font options for the printer. The card is hot-swappable (it can be installed while the printer is on).



Caution • Observe proper electrostatic safety precautions when handling any static-sensitive components such as circuit boards and printheads.

This illustration identifies the components used in this procedure.

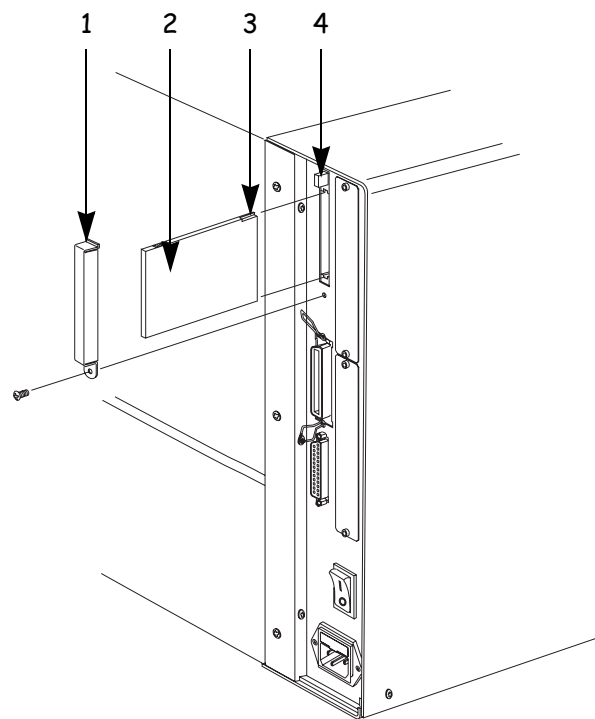

-
- | | |
|---|--------------------|
| 1 | PCMCIA card shield |
| 2 | Notch |
| 3 | PCMCIA card |
| 4 | Card-eject button |
-



To install the PCMCIA card, complete these steps:

1. Remove the PCMCIA card shield from the rear of the printer as shown.
2. Insert the PCMCIA card, with the notch **up**, into the card slot as shown. Insert it far enough to make the eject button pop out.
3. Reinstall the PCMCIA card shield over the PCMCIA card and card slot.

The printer is ready to operate with the additional memory or font option. To be sure that the card has successfully initialized, print a configuration label as instructed in *Print a Configuration Label* on page 31 and review it to see whether the new memory card information is listed.



Note • The PCMCIA card may take a few minutes to initialize. The PAUSE light flashes while the card initializes. If the card is already initialized, the PAUSE light flashes only once or twice after the card is installed.

CompactFlash Card

A CompactFlash card is a nonvolatile memory card that stores data even when the power to the printer is turned off. A Type I-compliant CompactFlash card holds extra memory or optional fonts for your printer.

This illustration shows the parts of the printer used in this procedure.

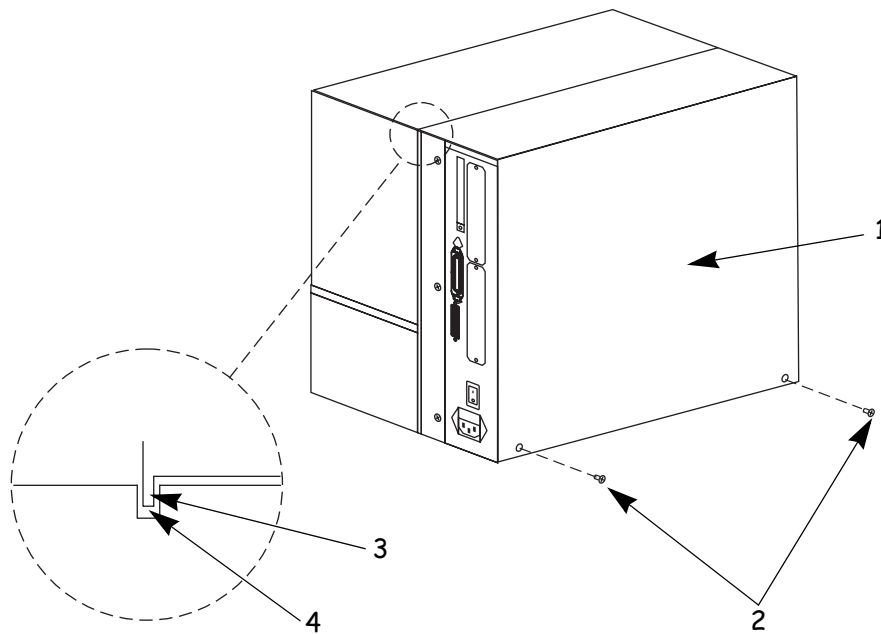

-
- | | |
|---|-------------------|
| 1 | Electronics cover |
| 2 | Screws |
| 3 | Channel |
| 4 | Lip of cover |
-



Caution • This procedure should only be performed by qualified service technicians.



Caution • Observe proper electrostatic safety precautions when handling any static-sensitive components such as circuit boards and printheads.

To install a CompactFlash card, complete these steps:

1. Turn the AC power Off (O).
2. Disconnect the AC power cord from the printer.
3. Remove the two screws near the bottom of the electronics cover.
4. Lift the electronics cover at the rear top corner. Pull the corner forward and up, then lift the cover up and away from the printer.
5. Insert the CompactFlash card into the card slot on the upper portion of the option board. Insert the card with the back (unlabeled) side of the card facing out. The card can be inserted only one way and should snap into place.

The following illustration shows where to insert the CompactFlash card.

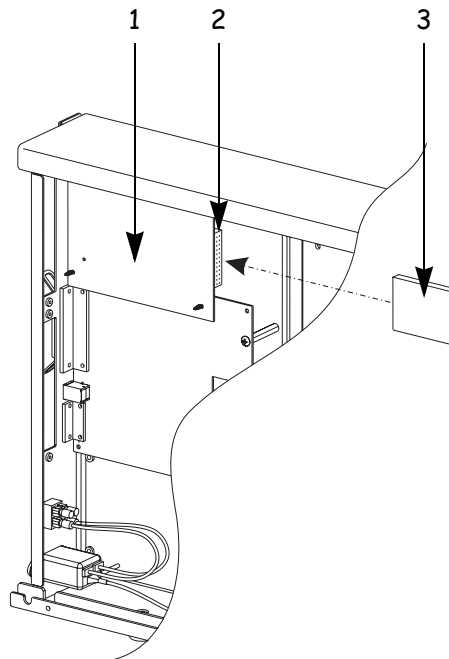

-
- | | |
|---|--------------------|
| 1 | Option board |
| 2 | Card slot |
| 3 | Compact flash card |
-

Memory Cards

CompactFlash Card

6. Reinstall the electronics cover by lowering the cover so the lip of the cover goes into the channel on the top of the printer.
7. Secure the cover by reinstalling the two screws near the bottom of the cover.
8. Reconnect the printer AC power cord.
9. Press and hold **CANCEL** while turning the printer On (**I**).

The printer prints a configuration label.

10. Check for the presence of additional memory or optional fonts by looking at the information on the configuration label.



Note • The CompactFlash card may take a few minutes to initialize. If the process is not successfully completed within 10 minutes, contact Technical Support at <http://www.bradyid.com> for assistance.

CHAPTER 7

Front Panel Controls

This appendix describes the function of the front panel.

Contents

Overview	72
Enter Setup Mode	72
Leave Setup Mode	73
Password-Protected Parameters	74
Default Password Value	75
Disable the Password Protection Feature	75
Front Panel LCD	76
ZebraNet® PrintServer II Option Display	98

Overview

After you have installed the labels and ribbon and printed a configuration label, you can change the printer's settings using the front panel controls. For an overview of the front panel, including descriptions of the buttons and lights, see *Front Panel on page 3*. If you need to restore the printer to its factory default settings, see *FEED and PAUSE Self Test on page 127*.

Many printer settings may be controlled by your printer's driver or label preparation software. Please refer to the driver or software documentation for more information.

Enter Setup Mode

To enter Setup Mode, complete these steps:

1. Press SETUP/EXIT to enter Setup Mode.
2. Press either NEXT/SAVE or PREVIOUS to scroll to the parameter that you wish to set.

Leave Setup Mode

To leave Setup Mode, complete these steps:

1. Press SETUP/EXIT.

The LCD displays **SAVE CHANGES**.

2. Press the left or right oval to display the save choices. The choices are described in the following table.

LCD Display	Description
PERMANENT	Permanently saves the changes. Values are stored in the printer even when power is turned off.
TEMPORARY	Saves the changes until you change them again or until power is turned off.
CANCEL	Cancels all changes from the time you pressed SETUP/EXIT except the darkness and tear-off settings (if they were changed).
LOAD DEFAULTS	Loads the factory defaults. To see the factory default values, see <i>Front Panel LCD</i> on page 76. Note • Loading factory defaults causes the printer to auto-calibrate.
LOAD LAST SAVE	Loads values from the last permanent save.

3. Press NEXT/SAVE to select the displayed choice.

When the configuration and calibration sequence is done, **PRINTER READY** displays.

Password-Protected Parameters

Certain parameters are password-protected by factory default, including the communication parameters.



Note • If the parameters are set incorrectly, the printer may function unpredictably.

The first attempt to change a password-protected parameter (pressing one of the ovals) requires you to enter a four-digit password at the **ENTER PASSWORD** display. The left oval changes the selected digit position; the right oval increases the selected digit value. After entering the password, press **NEXT/SAVE**. The parameter you wish to change is displayed. If the password was entered correctly, you can now change the value.

The first time that you attempt to change a password-protected parameter, the printer displays **ENTER PASSWORD**. Before you can change the parameter, you must enter the four-digit password. After you have entered the password correctly, you do not have to enter it again unless you leave Setup Mode by pressing **SETUP/EXIT** or by turning the printer Off (**O**).

To Enter a Password for a Password-Protected Parameter, complete these steps:

1. At the password prompt, use the left oval to change the selected digit position.
2. When you have selected the digit that you wish to change, use the right oval to increase the selected digit value. Repeat these two steps for each digit of the password.
3. After entering the password, press **NEXT/SAVE**.

The parameter you selected to change is displayed. If the password was entered correctly, you can change the value.

Default Password Value

The default password value is **1234**. The password can be changed using the **^KP** (Define Password) ZPL II instruction.

Disable the Password Protection Feature

You can disable the password protection feature so that it no longer prompts you for a password by setting the password to **0000** via the **^KPØ** ZPL/ZPL II command. To reenble the password-protection feature, send the ZPL/ZPL II command **^KPx**, where **x** can be any number from 1 to 9999.

Front Panel LCD

Use the LCD display on the front panel to adjust printer settings. In the following table, parameters are shown in the order in which they are displayed when you press NEXT/SAVE after entering setup mode. Throughout this process, press NEXT/SAVE to continue to the next parameter, or press PREVIOUS to return to the previous parameter in the cycle.

LCD	Description
PRINTER READY	This message displays after the Power-On Self Test (POST) is complete.
DARKNESS	<p>Adjusting Print Darkness</p> <p>Darkness settings depend on a variety of factors, including ribbon type, labels, and the condition of the printhead. You may adjust the darkness for consistent high-quality printing.</p> <p>If printing is too light, or if there are voids in printed areas, you should increase the darkness. If printing is too dark, or if there is spreading or bleeding of printed areas, you should decrease the darkness. Darkness settings also may be changed by the driver or software settings.</p> <p>The FEED Self Test described in the <i>FEED Self Test</i> on page 126 can also be used to determine the best darkness setting. Because the darkness setting takes effect immediately, you can see the results on labels that are currently printing.</p> <p>Caution • Set the darkness to the lowest setting that provides good print quality. If the darkness is set too high, the ink may smear, or the ribbon may burn through.</p> <ul style="list-style-type: none"> • Press the right oval to increase darkness. • Press the left oval to decrease darkness. <p>Default: +4</p> <p>Range: 0 to +30.0</p>

LCD	Description
PRINT SPEED	<p>Adjusting Print Speed</p> <p>Slower print speeds typically yield better print quality. Print speed changes take effect upon exiting the menu mode.</p> <ul style="list-style-type: none"> • Press the right oval to increase print speed. • Press the left oval to decrease print speed. <p>Default: 2 ips</p> <p>Range: 2 ips to +12 ips (depends on specific printer)</p>
TEAR OFF	<p>Adjusting the Tear-Off Position</p> <p>This parameter establishes the position of the labels over the tear-off/peel-off bar after printing.</p> <p>Each press of an oval adjusts the tear-off position by four dot rows.</p> <ul style="list-style-type: none"> • Press the right oval to increase value. • Press the left oval to decrease value. <p>Default: +0</p> <p>Range: -120 to +120</p>
PRINT MODE	<p>Selecting Print Mode</p> <p>Print mode settings tell the printer the method of label delivery that you wish to use. Be sure to select a print mode that your hardware configuration supports because some of the selections displayed are for optional printer features.</p> <ul style="list-style-type: none"> • Press either oval to display choices. <p>Default: Tear-off</p> <p>Selections: Tear-off, peel-off, cutter, rewind, applicator</p>

LCD	Description
MEDIA TYPE	<p>Setting Media Type</p> <p>This parameter tells the printer the type of media that you are using. Selecting continuous media requires that you include a label length instruction in your label format (^LLxxxx if you are using ZPL or ZPL II).</p> <p>When non-continuous media is selected, the printer feeds media to calculate label length (the distance between two recognized registration points of the inter-label gap, webbing, or alignment notch or hole).</p> <ul style="list-style-type: none"> • Press either oval to display choices. <p>Default: Continuous</p> <p>Selections: Continuous, non-continuous</p>
SENSOR TYPE	<p>Setting the Sensor Type</p> <p>This parameter tells the printer whether you are using media with a web (gap/space between labels, notch, or hole) to indicate the separations between labels or if you are using media with a black mark printed on the back. If your media does not have black marks for registration on the back, leave your printer at the default (web).</p> <ul style="list-style-type: none"> • Press either oval to display other choices. <p>Default: Web</p> <p>Selections: Web, mark</p>
PRINT METHOD	<p>Selecting Print Method</p> <p>The print method parameter tells the printer the method of printing that you wish to use: direct thermal (no ribbon) or thermal transfer (using thermal transfer media and ribbon).</p> <ul style="list-style-type: none"> • Press either oval to display choices. <p>Default: Thermal transfer</p> <p>Selections: Thermal transfer, direct thermal</p> <p>Note • Selecting direct thermal when using thermal transfer media and ribbon creates a printer error condition, but printing continues.</p>

LCD	Description
PRINT WIDTH	<p>Setting Print Width</p> <p>Print width determines the printable area across the width of the label.</p> <p>To change value shown:</p> <ol style="list-style-type: none"> 1. Press the left oval to move the cursor. 2. Press the right oval to increase the value of the digit. <p>Note • The printer does not accept any value larger than the maximum print width listed in <i>General Specifications</i> on page 133.</p> <p>To change the unit of measurement:</p> <ol style="list-style-type: none"> 1. Press the left oval until the unit of measurement is active. 2. Press the right oval to toggle to a different unit of measure (mm, inches, or dots). <p>Default Range: The default and range of acceptable values vary depending on what printer you have. See <i>General Specifications</i> on page 133 for further information about the ranges available for your model.</p>
MAXIMUM LENGTH	<p>Setting Maximum Length</p> <p>Maximum length is used in conjunction with the calibration procedure. The value of this setting is the maximum label length that is used during the media portion of the calibration process. Only a few labels are required to set media sensors. Always set the value that is at least 1 in. (25.4 mm) longer than the longest label to be used on the printer.</p> <ul style="list-style-type: none"> • To increase the value, press the right oval. • To decrease the value, press the left oval. <p>Default Range: The default and range of acceptable values vary depending on your printer's configuration. Values are adjustable in 1 in. (25.4 mm) increments.</p>

LCD	Description
EARLY WARNING	<p>Setting Early Warning</p> <p>When this parameter is enabled, the printer provides warnings when labels or ribbons are running low or when the printhead needs to be cleaned.</p> <p>Note • Labels per roll and ribbon length need to be updated when beginning use of the Early Warning System. Also, the printer does not make any adjustments when power is turned off and on.</p> <ul style="list-style-type: none"> • Press the right or left oval to display other choices. <p>Default: Media disabled, ribbon disabled, maintenance disabled</p> <p>Selections: Media disabled, media enabled, ribbon disabled, ribbon enabled, maintenance disabled, maintenance enabled</p> <p>To change the Early Warning settings,</p> <ol style="list-style-type: none"> 1. When the LCD displays EARLY WARNING, press the right or left oval until the desired setting is listed on the LCD. (If you are prompted for a password, enter your password using the instructions in <i>Password-Protected Parameters on page 74</i>.) 2. Press NEXT/SAVE to access the next early warning option. 3. Repeat this process to set the early warning for ribbon or maintenance (printhead cleaning). <p>When the printer detects that less than 15% of the labels or ribbon remain, WARNING MEDIA LOW or WARNING RIBBON LOW appears on the LCD. If the alert function has been enabled, an alert is also sent. When the printhead is opened then closed after a media or ribbon warning has been received, the LCD prompts with MEDIA REPLACED? or RIBBON REPLACED?. Press the right oval to select YES to clear the warning and reset the label counter.</p> <p>Note • When setting the early warning for maintenance, an additional setting appears after the media setting that prompts the LCD to ask HEAD CLEAN?</p> <ol style="list-style-type: none"> 1. Press the right oval to select YES. 2. Press SETUP/EXIT to exit setup mode. 3. Press NEXT/SAVE to save changes.

LCD	Description
LABELS PER ROLL	<p>Setting Labels Per Roll</p> <p>This parameter needs to be updated when setting the Early Warning System so the printer can provide early warnings when labels are running low.</p> <ul style="list-style-type: none"> • Press the right or left oval to display other choices. <p>Default: 900 labels Range: 100 labels to 9999 labels</p>
RIBBON LENGTH	<p>Setting Ribbon Length</p> <p>This parameter must be updated when setting the Early Warning System so the printer can provide early warnings when ribbon is running low.</p> <ul style="list-style-type: none"> • Press the right or left oval to display other choices. <p>Default: 450 m Range: 100 m to 450 m</p>
LIST FONTS	<p>List Fonts</p> <ul style="list-style-type: none"> • Press the right oval to print a label that lists the available fonts in the printer, including standard printer fonts plus any optional fonts. Fonts may be stored in RAM, Flash memory, font EPROMs, or font cards.
LIST BAR CODES	<p>List Bar Codes</p> <ul style="list-style-type: none"> • Press the right oval to print a label that lists the available bar codes in the printer.
LIST IMAGES	<p>List Images</p> <ul style="list-style-type: none"> • Press the right oval to print a label that lists the available images stored in the printer's RAM, Flash memory, optional EPROM, or optional memory card.
LIST FORMATS	<p>List Formats</p> <ul style="list-style-type: none"> • Press the right oval to print a label that lists the available formats stored in the printer's RAM, Flash memory, optional EPROM, or optional memory card.
LIST SETUP	<p>List Setup</p> <ul style="list-style-type: none"> • Press the right oval to print a label that lists the current printer configuration. (Same as CANCEL Self Test as shown in <i>CANCEL Self Test</i> on page 124.)

LCD	Description
LIST ALL	<p>List All</p> <ul style="list-style-type: none"> • Press the right oval to print a label that lists the available fonts, bar codes, images, formats, and the current printer configuration.
INITIALIZE CARD A B	<p>Initialize Memory Card</p> <p>Caution • Perform this operation only when it is necessary to erase all previously stored information from the memory card.</p> <ol style="list-style-type: none"> 1. When the LCD displays INITIALIZE CARD, press the left oval to select the A memory (internal CompactFlash) or the right oval to select B memory (PCMCIA card). (If you are prompted for a password, enter your password using the instructions in <i>Password-Protected Parameters</i> on page 74.) The front panel LCD asks ARE YOU SURE? 2. Do you wish to continue? <ul style="list-style-type: none"> • Press the left oval to select NO to cancel the request and return to INITIALIZE CARD prompt. • Press the right oval to select YES and begin initialization. FORMATting CARD displays. When formatting is complete, INITIALIZE CARD displays. <p>Note • Depending on the amount of memory in the memory card, initialization may take up to three minutes to complete.</p>

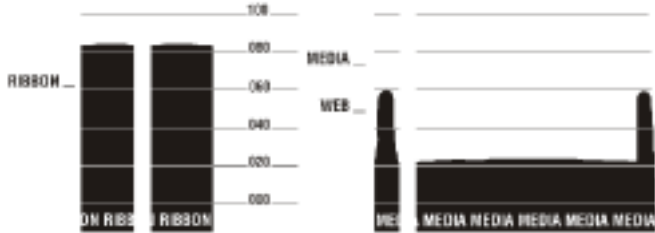
LCD	Description
INIT FLASH MEM	<p>Initialize Flash Memory</p> <p>Caution • Perform this operation only when it is necessary to erase all previously stored information from Flash memory.</p> <ol style="list-style-type: none"> When the LCD displays INITIALIZE CARD, press the right oval to select YES. (If you are prompted for a password, enter your password using the instructions in <i>Password-Protected Parameters</i> on page 74.) The LCD asks INITIALIZE FLASH. Press the right oval YES. The LCD asks ARE YOU SURE?. Do you wish to continue? <ul style="list-style-type: none"> Press the left oval to select NO to cancel the request and return to the INIT FLASH MEM prompt. Press the right oval to select YES and begin initialization. When formatting is complete, INIT FLASH MEM displays.
SENSOR PROFILE	<p>Sensor Profile</p> <p>The media sensor profile may be used to troubleshoot registration problems that may be caused when the media sensor detects preprinted areas on the media or experiences difficulty in determining web location.</p> <ul style="list-style-type: none"> Press the right oval to start this standard calibration procedure and print a media sensor profile. <p>See the media sensor profile below. If the sensitivity of the media and/or ribbon sensors must be adjusted, use <i>Calibrate Media and Ribbon Sensors</i> on page 84 to adjust the media and ribbon sensor sensitivity.</p> <p>Media Sensor Profile</p> 

LCD	Description
<p>MEDIA AND RIBBON CALIBRATE</p>	<p>Calibrate Media and Ribbon Sensors</p> <p>Use this procedure to adjust sensitivity of media and ribbon sensors.</p> <p>Important • This procedure must be followed exactly as presented. All of the steps must be performed even if only one of the sensors requires adjustment. You may press the left oval at any step in this procedure to cancel the procedure.</p> <ol style="list-style-type: none"> 1. Press the right oval to start the calibration procedure. The LOAD BACKING prompt displays. 2. Open the printhead. 3. Remove approximately 8 in. (203 mm) of labels from the backing, and pull the media into the printer so that only the backing is between the media sensors. 4. Leave the printhead open. 5. Press the right oval to continue. The REMOVE RIBBON prompt displays. 6. Remove the ribbon. 7. Close the printhead. 8. Press the right oval to continue. The message CALIBRATING PLEASE WAIT displays. The printer adjusts the scale (gain) of the signals that it receives from the media and ribbon sensors. On the sensor profile, this essentially corresponds to moving the peak of the graph up or down to optimize the readings for your application. When calibration is complete, RELOAD ALL displays. 9. Open the printhead and pull the media forward until a label is positioned under the media sensor. 10. Reload the ribbon. 11. Close the printhead. 12. Press the right oval to continue. The printer does a calibration equivalent to pressing CALIBRATE; during this process, the printer determines the label length. To see the new readings on the new scale, print a sensor profile.

LCD	Description
PARALLEL COMM	<p>Setting Parallel Communications</p> <p>Select the communications port that matches the one being used by the host computer.</p> <ul style="list-style-type: none"> • Press the right or left oval to display other choices. <p>Default: Bidirectional</p> <p>Selections: Bidirectional, unidirectional, or Twinax/coax</p>
SERIAL COMM	<p>Setting Serial Communications</p> <p>Select the communications port that matches the one being used by the host computer.</p> <ul style="list-style-type: none"> • Press the right or left oval to display other choices. <p>Default: RS-232</p> <p>Selections: RS-232, RS-422/485, RS-485 multidrop</p>
BAUD	<p>Setting Baud</p> <p>The baud setting of the printer must match the baud setting of the host computer for accurate communications to take place. Select the value that matches the one being used by the host computer.</p> <ul style="list-style-type: none"> • Press the right or left oval to display other choices. <p>Default: 9600</p> <p>Selections: 110, 300, 600, 1200, 2400, 4800, 9600, 14400, 19200, 28800, 38400, 57600, 115200</p>
DATA BITS	<p>Setting Data Bits</p> <p>The data bits of the printer must match the data bits of the host computer for accurate communications to take place. Set the data bits to match the setting being used by the host computer.</p> <p>Note • Code Page 850 requires the data bits to be set to 8 bits.</p> <ul style="list-style-type: none"> • Press the right or left oval to display other choices. <p>Default: 8 bits</p> <p>Selections: 7 bits, 8 bits</p>

LCD	Description
PARITY	<p>Setting Parity</p> <p>The parity of the printer must match the parity of the host computer for accurate communications to take place. Select the parity that matches the one being used by the host computer.</p> <ul style="list-style-type: none"> • Press the right or left oval to display other choices. <p>Default: None</p> <p>Selections: None, Even, Odd</p>
HOST HANDSHAKE	<p>Setting Host Handshake</p> <p>The handshake protocol of the printer must match the handshake protocol of the host computer for proper communications to take place. Select the handshake protocol that matches the one being used by the host computer.</p> <ul style="list-style-type: none"> • Press the right or left oval to display other choices. <p>Default: XON/XOFF</p> <p>Selections: XON/XOFF, RTS/CTS, DTR/DSR</p>
PROTOCOL	<p>Setting Protocol</p> <p>Protocol is a type of error checking system. Depending on the selection, an indicator may be sent from the printer to the host computer signifying that data has been received. Select the protocol that is requested by the host computer. Further details on protocol can be found in the <i>ZPL II Programming Guide</i>.</p> <ul style="list-style-type: none"> • Press the right or left oval to display other choices. <p>Default: None</p> <p>Selections: None, Zebra, ACK/NACK</p> <p>Note • Zebra is the same as ACK/NACK, except that Zebra response messages are sequenced. If Zebra is selected, the printer must use DTR/DSR host handshake protocol.</p>

LCD	Description
NETWORK ID	<p>Setting Network ID</p> <p>Network ID is used to assign a unique number to a printer used in an RS-422/RS-485 network. This gives the host computer the means to address a specific printer. If the printer is used in an RS-422/RS-485 network, you must select a network ID number. This does not affect TCP/IP or IPX networks.</p> <ol style="list-style-type: none"> 1. Press the left oval to move to the next digit position. 2. Press the right oval to increase the value of the digit. <p>Default: 000</p> <p>Range: 000 to 999</p>
COMMUNICA-TIONS	<p>Setting Communications Mode</p> <p>The communication diagnostics mode is a troubleshooting tool for checking the interconnection between the printer and the host computer. When DIAGNOSTICS is selected, all data sent from the host computer to the printer is printed as straight ASCII characters, with the hex value below the ASCII text. The printer prints all characters received, including control codes, like CR (carriage return). A sample printout is shown in <i>Communications Diagnostics Test</i> on page 127.</p> <p>Notes on diagnostic printouts are:</p> <ul style="list-style-type: none"> • FE indicates a framing error. • OE indicates an overrun error. • PE indicates a parity error. • NE indicates noise. <ol style="list-style-type: none"> 1. Press the right or left oval to toggle between the choices. 2. For any errors, check that your communication parameters are correct. 3. Set the print width equal to or less than the label width used for the test. See <i>Label Specifications</i> on page 137 for more information. <p>Default: Normal mode</p> <p>Selections: Normal mode, diagnostics</p>

LCD	Description
CONTROL PREFIX	<p>Control Prefix Character</p> <p>The printer looks for this two-digit hex character to indicate the start of a ZPL/ZPL II control instruction.</p> <p>Note • Do not use the same hex value for the control, format, and delimiter character. The printer must see different characters to work properly.</p> <ol style="list-style-type: none"> 1. Press the left oval to move to the next digit position. 2. Press the right oval to increase the value of the digit. <p>Default: 7E (tilde—displayed as a black square)</p> <p>Range: 00 to FF</p>
FORMAT PREFIX	<p>Format Prefix Character</p> <p>The format prefix is a two-digit hex value used as a parameter place marker in ZPL/ZPL II format instructions. The printer looks for this 2-digit hex character to indicate the start of a ZPL/ZPL II format instruction. See the <i>ZPL II Programming Guide Volume I</i> for more information.</p> <p>Note • Do not use the same hex value for the control, format, and delimiter character. The printer must see different characters to work properly.</p> <ol style="list-style-type: none"> 1. Press the left oval to move to the next digit position. 2. Press the right oval to increase the value of the digit. <p>Default: 5E (caret)</p> <p>Range: 00 to FF</p>
DELIMITER CHAR	<p>Delimiter Character</p> <p>The delimiter character is a 2-digit hex value used as a parameter place marker in ZPL/ZPL II format instructions. See the <i>ZPL II Programming Guide Volume I</i> for more information.</p> <p>Note • Do not use the same hex value for the control, format, and delimiter character. The printer must see different characters to work properly.</p> <ol style="list-style-type: none"> 1. Press the left oval to move to the next digit position. 2. Press the right oval to increase the value of the digit. <p>Default: 2C (comma)</p> <p>Range: 00 to FF</p>

LCD	Description
ZPL MODE	<p>Selecting ZPL Mode</p> <p>The printer remains in the selected mode until it is changed by this front panel instruction or by using a ZPL/ZPL II command. The printer accepts label formats written in either ZPL or ZPL II. This eliminates the need to rewrite any ZPL formats you already have. See the <i>ZPL II Programming Guide</i> for more information on the differences between ZPL and ZPL II.</p> <ul style="list-style-type: none"> • Press the right or left oval to display other choices. <p>Default: ZPL II</p> <p>Selections: ZPL II, ZPL</p>
MEDIA POWER UP	<p>Media Power Up</p> <p>This parameter sets the action of the labels when the printer is turned on.</p> <ul style="list-style-type: none"> • Press the right or left oval to display the choices. <p>Default: Calibration</p> <p>Selections: Feed, Calibration, Length, and No Motion</p> <ul style="list-style-type: none"> • Feed—feeds the labels to the first registration point. • Calibration—determines the length of the label. • Length—used in continuous mode to feed the last stored label length. • No Motion—the media does not move. You must press FEED to cause the printer to resynch to the start of the next label.
HEAD CLOSE	<p>Head Close</p> <p>This parameter sets the action of the labels when the printhead is closed.</p> <ul style="list-style-type: none"> • Press the right or left oval to display the choices. <p>Default: Calibration</p> <p>Selections: Feed, Calibration, Length, and No Motion</p> <ul style="list-style-type: none"> • Feed—feeds the labels to the first registration point. • Calibration—determines the length of the label. • Length—used in continuous mode to feed the last stored label length. • No Motion—the media does not move. You must press FEED to cause the printer to resynch to the start of the next label.

LCD	Description
BACKFEED	<p>Backfeed Sequence</p> <p>This parameter establishes when and how much label backfeed occurs after a label is removed or cut in Peel-Off, Cutter, and Applicator Modes. It has no effect in Rewind or Tear-Off Modes. This parameter setting can be superseded by the ~JS instruction when received as part of a label format (see the <i>ZPL II Programming Guide</i>).</p> <p>Note • The difference between the value entered and 100% establishes how much backfeed occurs before the next label prints. For example, a value of 40 means that 40% of the backfeed takes place after the label is removed or cut. The remaining 60% takes place before the next label prints. A value of BEFORE means that all backfeed takes place before the next label prints.</p> <ul style="list-style-type: none"> • Press the right or left oval to display other choices. <p>Default: Default (90%)</p> <p>Selections: Default, after, before, 10%, 20%, 30%, 40%, 50%, 60%, 70%, 80%, off</p>
LABEL TOP	<p>Adjusting Label Top Position</p> <p>The label top position adjusts the print position vertically on the label. Positive numbers adjust the label top position further down the label (away from the printhead), negative numbers adjust the position up the label (toward the printhead).</p> <p>The displayed value represents dots.</p> <ul style="list-style-type: none"> • To increase the value, press the right oval. • To decrease the value, press the left oval. <p>Default: +0</p> <p>Range: -120 to +120 dot rows</p>

LCD	Description
LEFT POSITION	<p>Adjusting Left Position</p> <p>This parameter establishes how far from the left edge of a label the format begins to print by adjusting horizontal positioning on the label. Positive numbers adjust the printing to the left by the number of dots selected, negative numbers shift printing to the right.</p> <p>The displayed value represents dots.</p> <ol style="list-style-type: none"> 1. Press the left oval to move the cursor. 2. Press the right oval to change between + and to increase the value of the digit. 3. For a negative value, enter the value before changing to the minus sign. <p>Default: 0000</p> <p>Range: -9999 to +9999</p>

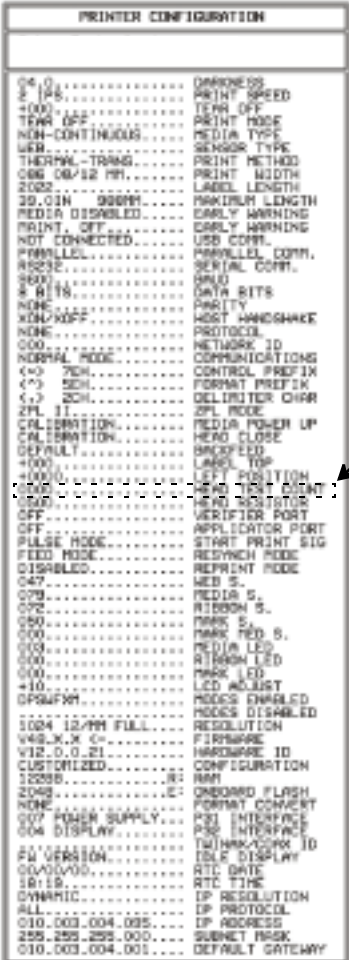
LCD	Description
HEAD TEST COUNT	<p>Setting the Head Test Count</p> <p>The printer periodically performs a test of the printhead functionality, called a printhead test or head test. This parameter establishes how many labels are printed between these internal tests.</p> <ol style="list-style-type: none"> 1. Press the left oval to move to the next digit position. 2. Press the right oval to increase the value of the digit. <p>Default: 0000 (disables the test)</p> <p>Range: 0000 to 9999</p> <p>Note • For the BP THT 600X-Plus II printer, this message would only be possible if the Head Test Count option is installed.</p>  <p>If the Head Test Option is installed, HEAD TEST COUNT will be listed on the configuration label.</p>

LCD	Description
HEAD RESISTOR	<p>Setting the Head Resistor Value</p> <p>Caution • This parameter should be changed only by qualified service personnel. Do not set the value higher than that shown on the printhead. Setting a higher value may damage the printhead.</p> <p>This value has been preset at the factory to match the resistance value of the printhead. It does not need to be changed unless the printhead or the main logic board is replaced.</p> <ol style="list-style-type: none"> 1. Look on the printhead for the label that shows the resistance value (Ω value). 2. Press the left oval to move to the next digit position. 3. Press the right oval to increase the value of the digit. <p>Initial Value: Factory-set to match the printhead shipped with your printer. Default Value: 0500 Range: 0500 to 2500</p>
VERIFIER PORT	<p>Setting the Verifier Port</p> <p>The auxiliary port is used to determine how the printer reacts to the online verifier. The three operating conditions for this port are:</p> <ul style="list-style-type: none"> • OFF: The verifier port is off. • VER-RPRNT ERR: Label reprinted if verifier detects an error. If a bar code is near the upper edge of the label, the label is fed out far enough to be verified and then backfed to allow the next label to print and be verified. • VER-THRUPUT: Allows greatest throughput but may not indicate a verification error immediately upon detection. May print from one to three labels before an error is recognized and printing stops. <p>• Press the right or left oval to display other choices.</p> <p>Default: Off Selections: Off, VER-RPRNT, VER-THRUPUT</p> <p>For more information on the operation of the optional verifier, see the documentation provided with that option.</p>

LCD	Description
<p>APPLICATOR PORT</p>	<p>Setting the Applicator Port Determines the action of the verifier port.</p> <p>Note • Set this value as suggested by the applicator manufacturer.</p> <ul style="list-style-type: none"> • Off: The applicator port is off. • Mode 1: Asserts the \simEND_PRINT signal low while the printer is moving the label forward. • Mode 2: Asserts the \simEND_PRINT signal high while the printer is moving the label forward. • Mode 3: Asserts the \simEND_PRINT signal low for 20 milliseconds when a label has been completed and positioned. Not asserted during continuous printing modes. • Mode 4: Asserts the \simEND_PRINT signal high for 20 milliseconds when a label has been completed and positioned. Not asserted during continuous printing modes. <ul style="list-style-type: none"> • Press the right or left oval to display other choices. <p>Default: Off</p> <p>Selections: Off, mode 1, mode 2, mode 3, mode 4</p>
<p>START PRINT SIG</p>	<p>Start Print Signal This parameter determines how the printer reacts to the Start Print Signal input on pin 3 of the applicator interface connector at the rear of the printer.</p> <ul style="list-style-type: none"> • In Pulse Mode, labels print when the signal transitions from HIGH to LOW. • In Level Mode, labels print as long as the signal is asserted LOW. <p>Caution • Start Print Signal is set by the applicator manufacturer and should not be changed unless the factory defaults have been reloaded. The printer must be returned to its designated setting for it to work properly.</p> <ul style="list-style-type: none"> • Press the right or left oval to display other choices. <p>Default: Pulse Mode</p> <p>Selections: Pulse Mode, Level Mode</p>

LCD	Description
RESYNCH MODE	<p>Resynch Mode</p> <p>This parameter determines how the printer reacts if the label synchronization is lost and the label top is not where expected.</p> <ul style="list-style-type: none"> • Feed Mode—If the label top is not where expected, the printer feeds a blank label to find the label top position. • Error Mode—If the label top is not where expected, the printer stops, enters Pause Mode, displays the message Error Condition Feed Label, flashes the ERROR light, and asserts the Service Required signal (pin 10 on the Applicator Interface Connector). <p>To resynch the media to the top of the label in Error Mode, press PAUSE to exit Pause Mode. The ERROR light stops flashing, and the Service Required signal is deactivated. The action of the printer is determined by the Head Close configuration selection (see <i>Head Close</i> on page 89).</p> <ul style="list-style-type: none"> • Press the right or left oval to toggle between choices. <p>Default: Feed Mode</p> <p>Selections: Feed Mode, Error Mode</p>
WEB S.	<p>These parameters are automatically set during the calibration procedure. They should be changed only by a qualified service technician. See the <i>Maintenance Manual</i> for more information on these parameters.</p> <ul style="list-style-type: none"> • Press NEXT/SAVE to scroll through these parameters.
MEDIA S.	
RIBBON S.	
MARK S.	
TAKE LABEL	
MARK MED S.	
MEDIA LED	
RIBBON LED	
MARK LED	

LCD	Description
LCD ADJUST	<p>LCD Adjustment</p> <p>This parameter allows you to adjust the contrast of your LCD if it is difficult to read.</p> <ol style="list-style-type: none"> 1. Press the left oval to move the cursor. 2. Press the right oval to toggle +/- or to increase the value of the digit. <p>Range: 00 to 19</p>
FORMAT CONVERT	<p>Format Convert</p> <p>Selects the bitmap scaling factor. The first number is the original dots per inch (dpi) value; the second, the dpi to which you would like to scale.</p> <p>Note • Not applicable on all printers.</p> <ul style="list-style-type: none"> • Press the right or left oval to display other choices. <p>Default: None</p> <p>Selections: None, 150 → 300, 150 → 600, 200 → 600, 300 → 600</p>
IDLE DISPLAY	<p>Idle Display</p> <p>This parameter selects the LCD options for the real-time clock.</p> <p>Note • If the default value is not selected, pressing either oval briefly displays the firmware version of the printer.</p> <ul style="list-style-type: none"> • Press the right or left oval to display other choices. <p>Default: Firmware version</p> <p>Selections: mm/dd/yy (24 hour), mm/dd/yy (12 hour), dd/mm/yy (24 hour), dd/mm/yy (12 hour)</p>
RTC DATE	<p>RTC (Real-time clock) Date</p> <p>This parameter allows you to set the date following the convention selected in IDLE DISPLAY.</p> <ol style="list-style-type: none"> 1. Press the left oval to move to the next digit position. 2. Press the right oval to increase the value of the digit.



LCD	Description
RTC TIME	<p>RTC (Real-time clock) Time</p> <p>This parameter allows you to set the time following the convention selected in IDLE DISPLAY.</p> <ol style="list-style-type: none"> 1. Press the left oval to move to the next digit position. 2. Press the right oval to increase the value of the digit.
LANGUAGE	<p>Selecting the Display Language</p> <p>This parameter allows you to change the language used on the LCD.</p> <ul style="list-style-type: none"> • Press the right or left oval to display other choices. <p>Default: English</p> <p>Selections: English, Spanish, French, German, Italian, Norwegian, Portuguese, Swedish, Danish, Spanish 2, Dutch, Finnish, Japanese</p>

ZebraNet® PrintServer II Option Display

These menu options display only if you have a ZebraNet® PrintServer II installed.

LCD	Explanation
IP RESOLUTION	<p>IP Resolution</p> <p>Depending on the selection, allows either the user (permanent) or the server (dynamic) to select the IP address. For more information, see the <i>PrintServer II™ Installation and User Guide</i>.</p> <ul style="list-style-type: none"> • Press the right or left oval to display other choices. <p>Default: Dynamic Selections: Dynamic, permanent</p>
IP PROTOCOLS	<p>IP Protocols</p> <p>If Dynamic was chosen in the previous parameter, this selection determines the method(s) by which the PrintServer II receives the IP address from the server. For more information, see the <i>PrintServer II™ Installation and User Guide</i>.</p> <ul style="list-style-type: none"> • Press the right or left oval to display other choices. <p>Default: All Selections: All, gleaning only, RARP, BOOTP, DHCP, DHCP/BOOTP</p>
IP ADDRESS	<p>IP Address</p> <p>This parameter allows you to select the IP address if Permanent was chosen in IP RESOLUTION. (If Dynamic was chosen, the user cannot select the address.) For more information, see the <i>PrintServer II™ Installation and User Guide</i>.</p> <ol style="list-style-type: none"> 1. Press the left oval to move to the next digit position. 2. Press the right oval to increase the value of the digit.

LCD	Explanation
SUBNET MASK	<p>Subnet Mask</p> <p>This parameter selects the part of the IP address that is considered to be part of the local network. It can be reached without going through the default gateway.</p> <ul style="list-style-type: none"> • Press the right or left oval to display other choices. <p>Default: Permanent (user must set)</p> <p>Selections: Dynamic (user may set, but server can assign), permanent</p>
DEFAULT GATEWAY	<p>Default Gateway</p> <p>This parameter allows you to select the IP address that the network traffic is routed through if the destination address is not part of the local network.</p> <ol style="list-style-type: none"> 1. Press the left oval to move to the next digit position. 2. Press the right oval to increase the value of the digit.



CHAPTER 8

Routine Maintenance

Cleaning your printer regularly maintains print quality and may extend the life of the printer. This appendix provides routine cleaning and maintenance procedures.

Contents

Cleaning Schedule	102
Clean Exterior	103
Clean Interior	103
Printhead and Platen Roller	103
Sensors	105
Snap Plate	107
Cutter	108
Replace Fuse	109

Cleaning Schedule

The recommended cleaning schedule is shown in the table below. See the following pages for specific procedures.

Caution • Use only the cleaning agents indicated. Brady is not responsible for damage caused by any other fluids being used on this printer.

Area	Method	Interval
Printhead	Solvent*†	Perform these procedures at the following times: <ul style="list-style-type: none"> • When CLEAN HEAD NOW appears. • Direct Thermal Print Mode: After every roll of labels or 500 ft (150 m) of fanfold labels. • Thermal Transfer Print Mode: After every roll (1500 ft or 450 m) of ribbon.
Platen roller	Solvent*	
Transmissive (media) sensor	Air blow	
Black mark sensor	Air blow	
Media path	Solvent*	
Ribbon sensor	Air blow	
Label-available sensors	Air blow	Monthly
Tear-off/peel-off bar	Solvent*	
Snap plate	Solvent*	As needed
Cutter	Solvent*	

* Brady recommends using a solution of 90% isopropyl alcohol and 10% deionized water.

† For 600 dpi printers, use cleaning film. This specially coated material removes contamination buildup without damaging the printhead. Call an authorized Brady distributor for more information.

Clean Exterior

Clean the outside surfaces of the printer with a lint-free cloth. Use a mild detergent solution or desktop cleaner sparingly, as needed.

Caution • Do not use harsh or abrasive cleaning agents or solvents.

Clean Interior

After every four rolls of labels, inspect the inside of the printer. Use a soft bristle brush or a vacuum cleaner to remove any dirt and lint from the interior of the printer.

Printhead and Platen Roller

After every roll of ribbon, clean the printhead. Clean the printhead more often if you see inconsistent print quality, such as voids in the bar code or graphics.

For 200 and 300 dpi printers Clean after every roll (1500 feet or 450 m) of thermal transfer ribbon or after every roll (500 feet or 150 m) of direct thermal labels or when **CLEAN HEAD NOW** appears on the LCD.

For 600 dpi printers Clean after each roll (500 feet or 150 m) of labels or when **CLEAN HEAD NOW** appears on the LCD.



Notes • You do **not** need to turn off the printer before cleaning the printhead.

If power is turned off, all label formats and images, as well as any temporarily saved parameter settings stored in the printer's internal memory, are lost. When power is turned back on, these items must be reloaded.

If power is removed from a 600 dpi printer when cleaning the printhead, the **CLEAN HEAD NOW** warning shown on the LCD will **not** disappear.

Routine Maintenance

Clean Interior



Caution • The printhead is hot and can cause severe burns. Allow the printhead to cool.



Caution • Observe proper electrostatic safety precautions when handling any static-sensitive components such as circuit boards and printheads.

To clean the printhead and platen roller, complete these steps:

1. Open the printhead.
2. Remove the labels and ribbon (if loaded).
3. Use a solution of 90% isopropyl alcohol and 10% deionized water on an applicator to wipe along the print elements from end to end, as shown in the following illustration. (The print elements are on the brown strip on the printhead.) Allow a few seconds for the solvent to evaporate.

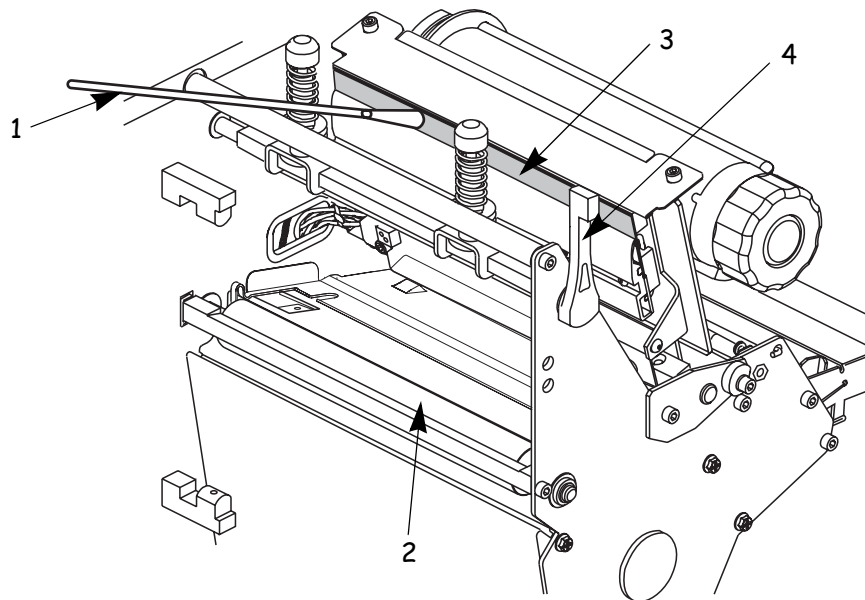

-
- | | |
|---|--------------------------|
| 1 | Applicator |
| 2 | Platen roller |
| 3 | Printhead print elements |
| 4 | Printhead lever |
-

4. Rotate the platen roller and clean thoroughly with solvent and an applicator.
5. Brush or vacuum any accumulated paper lint and dust away from the rollers.
6. Reload ribbon (if required).

7. Close the printhead.



Note • If print quality does not improve when you perform this procedure, clean the printhead with *Save-a-Printhead* cleaning film. This specially coated material removes contamination buildup without damaging the printhead. Call an authorized Brady distributor for more information.

Sensors

Brush or vacuum any accumulated paper lint and dust off the sensors whenever the sensors are blocked. At minimum, clean the sensors according to the recommendations in *Cleaning Schedule* on page 102.

Ribbon and Label-Available Sensor Locations

The ribbon sensor and optional label-available sensor are shown in the following illustration.

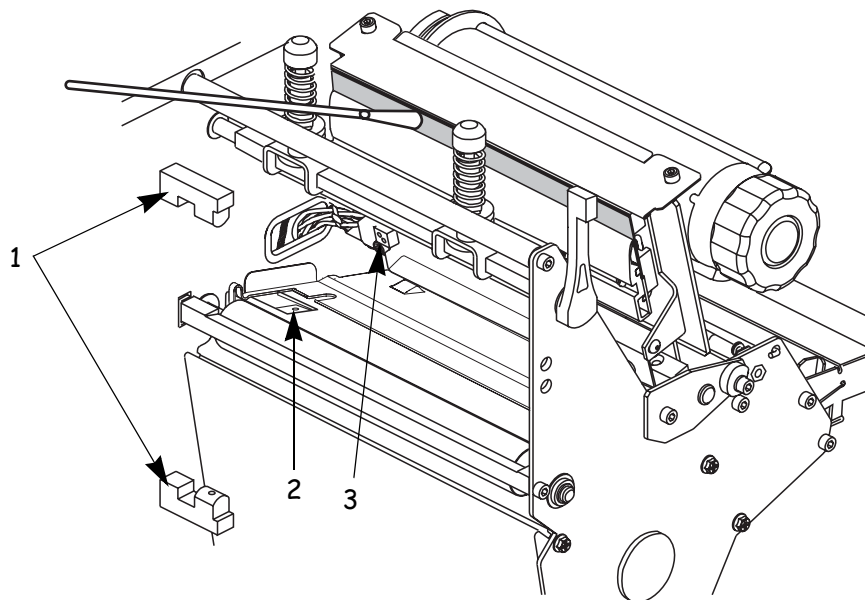

-
- | | |
|---|-------------------------|
| 1 | Label-available sensors |
| 2 | Black mark sensor |
| 3 | Ribbon sensor |
-

Transmissive (Media) Sensor Locations

Upper and lower transmissive (media) sensors are shown in the following illustrations.

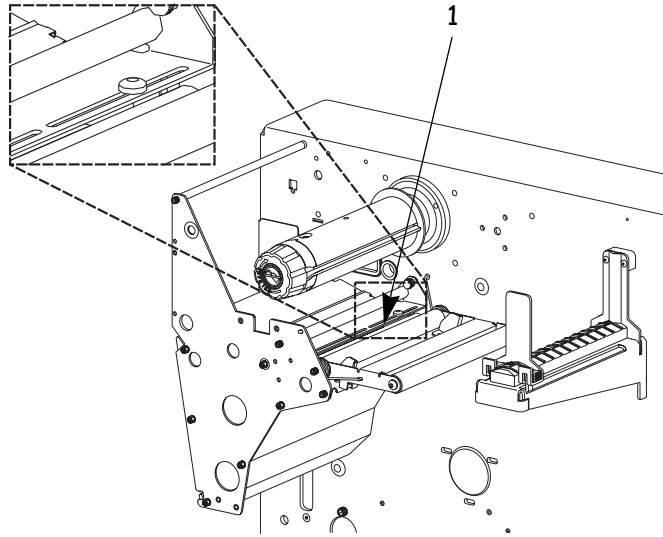

1 Upper media sensor

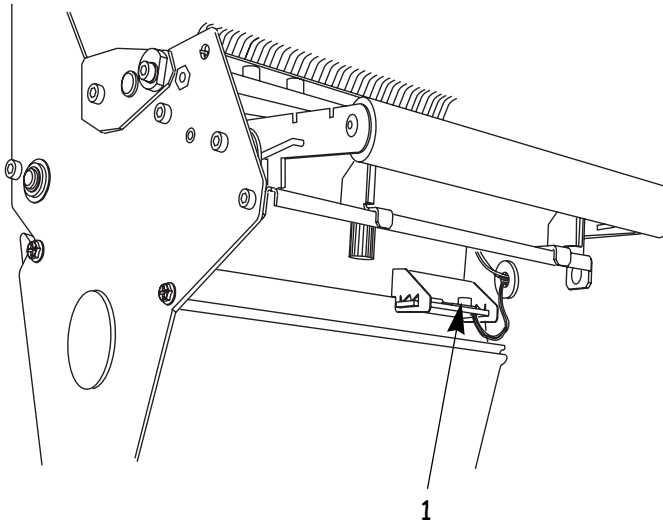

1 Lower media sensor

Snap Plate

Clean the snap plate when label adhesive or a label is stuck to the underside of the snap plate. This illustration shows snap plate and the loops on either side.

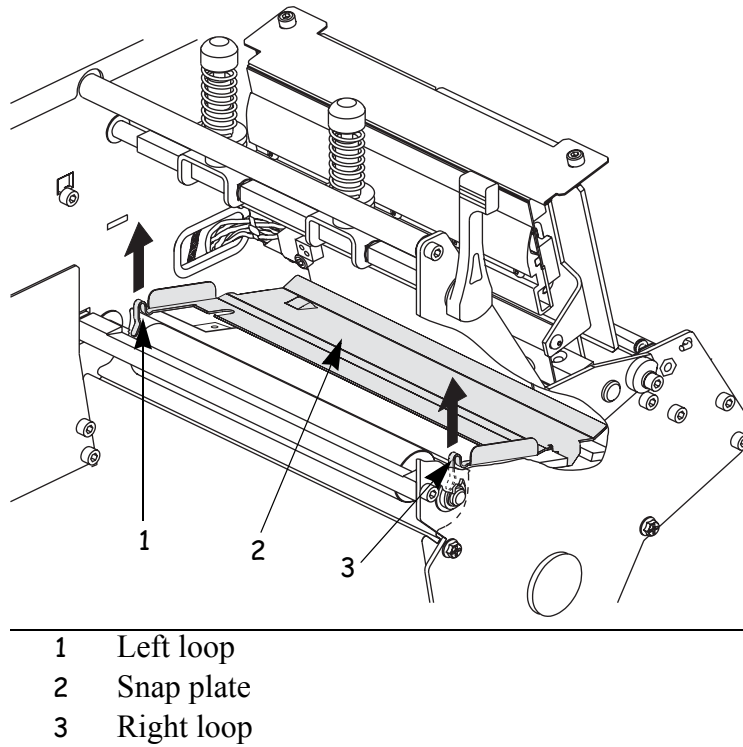

To clean the snap plate, complete these steps:

1. Insert a small-blade screwdriver or similar tool into the loop on the left side of the snap plate.

! **Important** • Take care not to bend, twist, or otherwise deform the loops. If the snap plate is damaged in any way, you may need a new plate for proper ribbon sensing.

2. Gently lift the left side of the snap plate.
3. Insert a small-blade screwdriver or similar tool into the loop on the right side of the snap plate.
4. Gently lift the right side of the snap plate.
5. Remove the snap plate from the printer.
6. Clean the snap plate with cleaning solvent and a soft cloth.

Routine Maintenance

Clean Interior

7. To reinstall the snap plate, insert the two tabs on the bottom of the snap plate into the two slots of the media path.
8. Slide the snap plate toward you.
9. Press down on the loops to lock the snap plate into place.

Cutter

If the cutter is not cutting the labels cleanly or if it jams with labels, clean the cutter.



Caution • The cutter blade is sharp. Do not touch or rub the blade with your fingers.

To clean the cutter, complete these steps:

1. Turn Off (O) the printer.
2. Unplug the power cord.
3. Clean the stationary cutter blade with solvent.

If this does not remove label fragments and adhesive, contact an authorized service technician.

Replace Fuse

The instructions that follow are for the BP THT 360X-Plus II series printers only. The BP THT 300X-Plus II and BP THT 600X-Plus II fuses must be replaced only by an authorized service technician.



Caution • Turn the AC power switch Off (O) and remove the power cord before performing this procedure.

The printer uses a metric-style fuse (5 × 20 mm IEC) rated at F5A, 250 V. The AC power entry module comes with two approved fuses in the fuse holder: one is in-circuit, and the second is provided as a spare. The end caps of the fuse must bear the certification mark of a known international safety organization.

To replace a faulty fuse, complete these steps:

1. Use a small-blade screwdriver or similar tool to remove the fuse holder.

The fuse holder is part of the AC power entry module at the rear of the printer. This illustration identifies the parts of the AC power entry module.

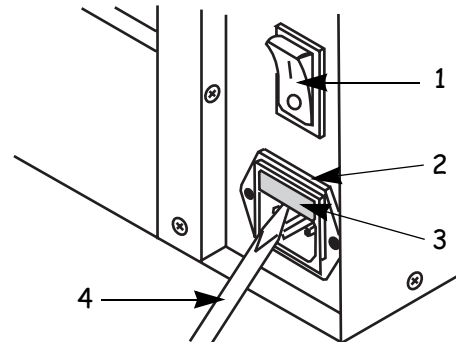

-
- | | |
|---|-------------------------|
| 1 | Power switch |
| 2 | Fuse holder |
| 3 | AC power entry module |
| 4 | Small-blade screwdriver |
-

Routine Maintenance

Replace Fuse

2. Remove the faulty fuse and install a new fuse in the in-circuit position as shown.



Important • If you use the spare fuse, be sure to order a replacement fuse from an authorized Brady distributor. The spare fuse should be the exact type and rating as the original in-circuit fuse.

This illustration identifies the parts of the fuse holder.

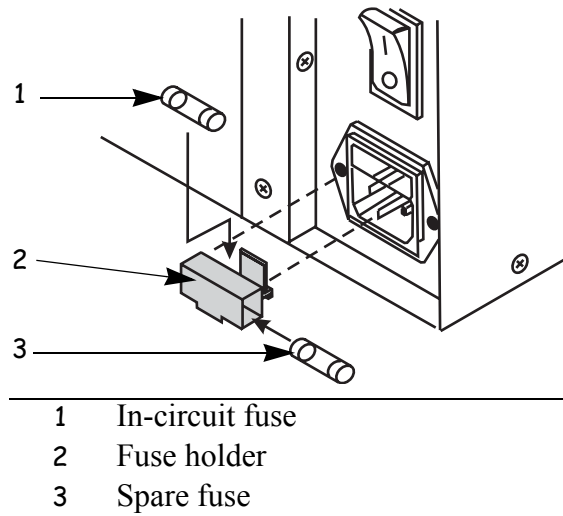

3. Snap the fuse holder back into the AC power entry module.

4. Reconnect the power cord, and turn the printer On (I).



Note • If the printer does not power on, an internal component failure may have occurred, and the printer requires servicing by an authorized service technician.

CHAPTER 9

Troubleshooting

This chapter provides you with information about LCD, print quality, communications, and other errors that you might need to troubleshoot.

Contents

Troubleshooting	112
LCD Error Messages	113
Print Quality Problems	118
Communications Problems	121
Printer Diagnostics	123
Power-On Self Test	123
Additional Printer Self Tests	123
Communications Diagnostics Test	127
Additional Printer Diagnostics	127

Troubleshooting

If an error condition exists with the printer, review this checklist:

- Is there an error message on the LCD? If yes, see *LCD Error Messages on page 113* for more information.
- Is the CHECK RIBBON light on when ribbon is loaded properly or are non-continuous labels are being treated as continuous labels? If yes, see *Media and Ribbon Sensor Calibration on page 34*.
- Are you experiencing problems with print quality? If yes, see *Print Quality Problems on page 118*.
- Are you experiencing communications problems? If yes, see *Communications Problems on page 121*.

If the labels are not printing or advancing correctly, review this checklist:

- Are you using the correct type of labels? Review the types of label in *Types of Media on page 17*.
- Review the label- and ribbon-loading illustrations, starting with *Load the Printer on page 22*.
- Check the position of the media sensor and move if necessary, as shown in *Adjust Sensors on page 34*.
- Does the printhead need to be adjusted? See *Adjust the Printhead on page 39* for more information.
- Do the sensors need to be calibrated? See *Media and Ribbon Sensor Calibration on page 34* for more information.

If none of the above suggestions correct the problem, review this checklist:

- Perform one or more of the self-tests given in *Printer Diagnostics on page 123*. Use the results to help identify the problem.
- If you are still having problems, see *Support on page xx* for customer support information.

LCD Error Messages

The LCD displays messages when there is an error. This table identifies LCD errors, the possible causes, and the recommended solutions.



LCD	Possible Cause	Recommended Solution
Ribbon Out	Thermal Transfer Mode— Ribbon is not loaded or is loaded incorrectly.	Load the ribbon correctly, following directions in <i>Load Ribbon</i> on page 26.
	Thermal Transfer Mode— Ribbon is loaded but the ribbon sensor is not sensing the ribbon.	Adjust the media and ribbon sensors. See <i>Media and Ribbon Sensor Calibration</i> on page 34.
	Direct Thermal Mode— Ribbon is loaded.	Make sure that ribbon is not loaded and that the printer is in Direct Thermal Print Mode. See <i>Selecting Print Method</i> on page 78.
	Direct Thermal Mode— Settings are incorrect.	Make sure the printer driver and software settings are compatible with Direct Thermal Print Mode.
PAPER OUT	Labels are not loaded or are loaded incorrectly.	Load the labels correctly. See <i>Load the Printer</i> on page 22.
	Media Sensor is not adjusted correctly.	Check the position of the media sensors, and adjust if necessary. See <i>Media and Ribbon Sensor Calibration</i> on page 34.
	Printer is set for non-continuous labels but continuous labels are loaded.	<ul style="list-style-type: none"> • Make sure the labels and the Media Type settings match. See <i>Setting Media Type</i> on page 78. • Make sure the printer driver or software settings match the label and Media Type settings. • Calibrate the printer. For more information, see <i>Calibrate the Printer</i> on page 33.



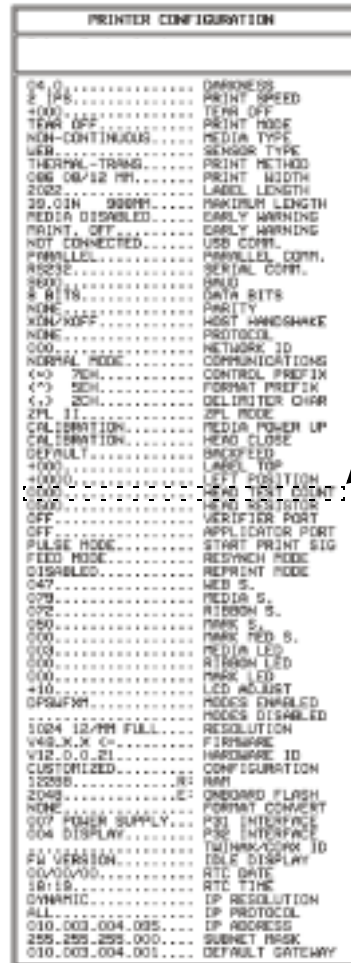

LCD	Possible Cause	Recommended Solution
HEAD OPEN	The printhead is not fully closed.	Close the printhead.
HEAD ELEMENT BAD	One or more of the printhead elements failed the printhead element test.	<ul style="list-style-type: none"> If the failed elements affect your printing application, replace the printhead. To override this error, disable the head test count feature on the front panel by defaulting the value to 0000.



Note • For the BP THT 600X-Plus II printer, this message would only be possible if the Head Test Count option is installed.



If the Head Test Option is installed, HEAD TEST COUNT will be listed on the configuration label.



LCD	Possible Cause	Recommended Solution
RIBBON IN	Ribbon is loaded, but the printer is set for Direct Thermal mode.	<ul style="list-style-type: none"> • To operate in Direct Thermal mode, remove the ribbon. • To operate in Thermal Transfer mode, leave the ribbon loaded and change the print method to Thermal Transfer. See <i>Selecting Print Method</i> on page 78. • Ensure that the printer driver and/or software settings are correctly set (if applicable).
HEAD TOO HOT	The printhead is over temperature.	<p>Printing automatically resumes when the printhead elements cool to an acceptable operating temperature.</p> <p> Caution • The printhead is hot and can cause severe burns. Allow the printhead to cool.</p> <p> Caution • Observe proper electrostatic safety precautions when handling any static-sensitive components such as circuit boards and printheads.</p>





LCD	Possible Cause	Recommended Solution
CLEAN HEAD NOW	The printhead requires cleaning.	<p>Clean the printhead according to the instructions in <i>Printhead and Platen Roller</i> on page 103.</p> <p> Caution • The printhead is hot and can cause severe burns. Allow the printhead to cool.</p> <p> Caution • Observe proper electrostatic safety precautions when handling any static-sensitive components such as circuit boards and printheads.</p> <hr/> <p>If the message does not go away after the printhead is cleaned, open the printhead and then close it.</p>
HEAD COLD	<p> Caution • An improperly connected printhead data or power cable can cause this error message. The printhead can still be hot enough to cause severe burns. Allow the printhead to cool.</p> <hr/> <p>The printhead is under temperature.</p> <hr/> <p>Printhead data cable is not properly connected.</p>	<p>Continue printing while the printhead reaches the correct operating temperature. If the error remains, the environment may be too cold for proper printing. Relocate the printer to a warmer area.</p> <hr/> <p>Disconnect and reconnect the data cable to the printhead. Ensure that the cable connector is fully inserted into the printhead connector.</p> <p> Caution • Observe proper electrostatic safety precautions when handling any static-sensitive components such as circuit boards and printheads.</p>



LCD	Possible Cause	Recommended Solution
CUTTER JAMMED	Cutter blade is in the media path.	<p>Turn off the printer power and unplug the printer. Inspect the cutter module for debris and clean as needed following the cleaning instructions in <i>Cutter</i> on page 108.</p> <p> Caution • The cutter blade is sharp. Do not touch or rub the blade with your fingers.</p>
OUT OF MEMORY	There is not enough memory to perform the function shown on the second line of the error message.	<p>Turn the printer off then back on to clear memory, and try to print again. If the error recurs, there is insufficient memory for the label length, downloaded fonts or graphics, and images.</p> <hr/> <p>Ensure that the device, such as Flash memory or PCMCIA card, is installed and not write-protected or full. See <i>Memory Cards</i> on page 65.</p> <p> Caution • Observe proper electrostatic safety precautions when handling any static-sensitive components such as circuit boards and printheads.</p> <hr/> <p>Ensure that the data is not directed to a device that is not installed or available.</p>

Print Quality Problems

This table identifies problems with print quality, the possible causes, and the recommended solutions.

Problem	Possible Cause	Recommended Solution
General print quality issues	You are using an incorrect combination of labels and ribbon for your application.	Consult an authorized Brady distributor for information and advice.
	The printer is set at the incorrect print speed.	For optimal print quality, set the print speed to the lowest possible setting for your application via ZPL II, the driver, or the software. See <i>Adjusting Print Speed</i> on page 77.
	The printer is set at an incorrect darkness level.	For optimal print quality, set the darkness to the lowest possible setting for your application via the front panel, the driver, or the software. See <i>Adjusting Print Darkness</i> on page 76.
	The printhead is dirty.	Clean the printhead according to the instructions in <i>Printhead and Platen Roller</i> on page 103.
		Caution • The printhead is hot and can cause severe burns. Allow the printhead to cool.
		Caution • Observe proper electrostatic safety precautions when handling any static-sensitive components such as circuit boards and printheads.

Problem	Possible Cause	Recommended Solution
<p>There is light printing (or no printing) on the left or right side of the label or the printed image is not sharp.</p>	<p>The toggle pressure needs to be adjusted.</p>	<p>Follow the instructions in <i>Adjust the Printhead</i> on page 39.</p> <p> Caution • Observe proper electrostatic safety precautions when handling any static-sensitive components such as circuit boards and printheads.</p>
<p>Gray lines on blank labels with no consistent pattern</p>	<p>The printhead is dirty.</p>	<p>Clean the printhead according to the instructions in <i>Printhead and Platen Roller</i> on page 103.</p> <p> Caution • The printhead is hot and can cause severe burns. Allow the printhead to cool.</p> <p> Caution • Observe proper electrostatic safety precautions when handling any static-sensitive components such as circuit boards and printheads.</p>
<p>Light, consistent vertical lines running through the labels</p>	<p>The printhead or platen roller is dirty.</p>	<p>Clean the printhead and platen roller as instructed in <i>Printhead and Platen Roller</i> on page 103.</p> <p> Caution • The printhead is hot and can cause severe burns. Allow the printhead to cool.</p> <p> Caution • Observe proper electrostatic safety precautions when handling any static-sensitive components such as circuit boards and printheads.</p>

Problem	Possible Cause	Recommended Solution
Intermittent creases on the left and right edges of the labels	There is too much toggle pressure on the printhead.	Reduce the toggle pressure. See <i>Adjust the Printhead</i> on page 39.
		 <p>Caution • Observe proper electrostatic safety precautions when handling any static-sensitive components such as circuit boards and printheads.</p>
Wrinkled Ribbon	The ribbon is not loaded correctly.	Load the ribbon correctly. See <i>Load Ribbon</i> on page 26.
	The darkness setting is incorrect.	Set the darkness to the lowest possible setting for good print quality. See <i>Adjusting Print Darkness</i> on page 76.
	Incorrect printhead pressure or balance.	Set the pressure to the minimum required for good print quality. See <i>Adjust the Printhead</i> on page 39.
		 <p>Caution • Observe proper electrostatic safety precautions when handling any static-sensitive components such as circuit boards and printheads.</p>
	The labels are not feeding correctly. They are shifting from side to side.	Make sure that the media guide and media supply guide touch the edge of the media.
		Adjust the ribbon strip plate.

Communications Problems

This table identifies problems with communications, the possible causes, and the recommended solutions.

Problem	Possible Cause	Recommended Solution
A label format was sent to the printer but was not recognized. The DATA light does not flash.	The communication parameters are incorrect.	Check the printer driver or software communications settings (if applicable).
		If you are using serial communication, check the serial port setting in the front panel menu. See <i>Setting Serial Communications</i> on page 85.
		Make sure you are using the correct communication cable. See <i>Data Cable Requirements</i> on page 16 for the requirements.
		Using the front panel controls, check the protocol setting. It should be set to NONE . See <i>Setting Protocol</i> on page 86.
A label format was sent to the printer. Several labels print, then the printer skips, misplaces, misses, or distorts the image on the label.	The host is set to EPP parallel communications.	Change the settings on the computer host to standard parallel communications. See <i>Setting Parallel Communications</i> on page 85.
	The serial communication settings are incorrect.	Ensure that the flow control settings match.
		Check the communication cable length. See <i>Data Cable Requirements</i> on page 16 for requirements.
		Check the printer driver or software communications settings (if applicable).

Problem	Possible Cause	Recommended Solution
A label format was sent to the printer but was not recognized. The DATA light flashes but no printing occurs.	The prefix and delimiter characters set in the printer do not match the ones in the label format.	Verify the prefix and delimiter characters. See <i>Format Prefix Character</i> on page 88 and <i>Delimiter Character</i> on page 88 for the requirements.
	Incorrect data is being sent to the printer.	Ensure that ZPL is being used. Check the communication settings on the computer. Ensure that they match the printer settings.
The printer fails to calibrate or detect the top of the label.	The printer was not calibrated for the label being used.	Perform the calibration procedure in <i>CANCEL Self Test</i> on page 124.
	The printer is configured for continuous media.	Set the media type to non-continuous media. See <i>Setting Media Type</i> on page 78.
	The driver or software configuration is not set correctly.	Driver or software settings produce ZPL commands that can overwrite the printer configuration. Check the driver or software media-related setting.

Printer Diagnostics

Self tests give information about the condition of the printer. The most commonly used are the Power-On and the CANCEL self test.

Caution • Be sure that the print width is set to match the label width you are using before running any self tests. If the labels are not wide enough, the test may print on the platen roller and damage it.

Power-On Self Test

The Power-On Self Test (POST) is performed automatically each time the printer is turned on. During either test sequence, the front panel LEDs light up and the LCD monitors the progress of the POST. If the printer fails any of these tests, **FAILED** shows on the LCD. If this occurs, notify an authorized Brady distributor.

Additional Printer Self Tests

These self tests produce sample printouts and provide specific information that help determine the operating conditions for the printer.

Each self test is enabled by pressing a specific front panel key or combination of keys while turning the power On (**I**). Keep the key(s) depressed until the **DATA** light turns off. When the POST is complete, the selected self test starts automatically.



Note • When performing a self test, do not send a label format to the printer. For remote hosts, disconnect all data interface cables from the printer. For printers in Peel-Off Mode, remove the labels as they come out of the printer.

CANCEL Self Test

The CANCEL self test prints a configuration label, which tells you the current settings for the printer.

To perform the CANCEL Self Test, complete these steps:

1. Turn Off (O) the printer.
2. Press and hold CANCEL while turning the power On (I). Hold CANCEL until the DATA light turns off.

A configuration label prints.

PRINTER CONFIGURATION	
04.0	DARKNESS
2 IPS	PRINT SPEED
+000	TEAR OFF
TRNG OFF	PRINT MODE
NON-CONTINUOUS	MEDIA TYPE
USB	SENSOR TYPE
THERMAL-TRANS	PRINT METHOD
086.08/32 MM	PRINT WIDTH
2032	LABEL LENGTH
39.03H 980PPH	MAXIMUM LENGTH
MEDIA DISABLED	EARLY WARNING
PRINT OFF	DAILY WARNING
NOT CONNECTED	USB CONF.
PARALLEL	PARALLEL CONF.
RS232	SERIAL CONF.
9600	BPS
8 BIT	DATA BITS
NONE	PARITY
XON/XOFF	HOST HANDSHAKE
NONE	PROTOCOL
000	NETWORK ID
NORMAL MODE	COMMUNICATIONS
<N> PCH	CONTROL PREFIX
<F> SCH	FORMAT PREFIX
<L> ZCH	DELIMITER CHAR
ZPL II	ZPL MODE
CALIBRATION	FEEDER POWER UP
CALIBRATION	HEAD CLOSE
DEFAULT	BACKFEED
+000	LABEL TOP
+0000	LEFT POSITION
0000	HEAD TEST COUNT
0000	HEAD RESISTOR
OFF	VERIFIER PORT
OFF	APPLICATION PORT
PULSE MODE	START PRINT SIG
FEED MODE	RESYNCH MODE
DISABLED	REPRINT MODE
047	MEDIA S.
078	RIBBON S.
072	MARK S.
050	MARK RED S.
000	MEDIA LED
000	ATRINK LED
000	MARK LED
+10	LCD ADJUST
DPSMFM	MODES ENABLED
	MODES DISABLED
1004 12/PPH FULL	RESOLUTION
V48.K.X C<	FIRMWARE
V12.D.O.21	HARDWARE ID
CUSTOMIZED	CONFIGURATION
32088	RAM
2048	ONBOARD FLASH
NONE	FORMAT CONTACT
007 FODER SUPPLY	P31 INTERFACE
004 DISPLAY	P30 INTERFACE
	TWINK/WORK ID
PL VERSION	SELF DISPLAY
04/04/05	RTC DATE
10:18	RTC TIME
DYNAMIC	IP RESOLUTION
ALL	IP PROTOCOL
010.003.004.005	IP ADDRESS
255.255.255.000	SUBNET MASK
010.003.004.005	DEFAULT GATEWAY

The printer configuration can be changed by performing a calibration procedure. See [Print a Configuration Label on page 31](#) for more information.

PAUSE Self Test

This self test can be used to provide the test labels required when making adjustments to the printer's mechanical assemblies. See the sample printout below.

To perform a PAUSE self test, complete these steps:

1. Turn Off (O) the printer.
2. Press and hold PAUSE while turning the power On (I). Hold PAUSE until the DATA light turns off.
 - The initial self test prints 15 labels at 2.4 in. (61 mm) per second, then automatically pauses the printer. When PAUSE is pressed, an additional 15 labels print. The labels are like the one shown below.

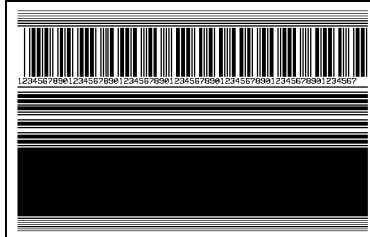

- While the printer is paused, pressing CANCEL alters the self test. When PAUSE is pressed, 15 labels print at 6 in. or 152 mm per second.
- While the printer is paused, pressing CANCEL again alters the self test a second time. When PAUSE is pressed, 50 labels print at 2.4 in. (61 mm per second).
- While the printer is paused, pressing CANCEL again alters the self test a third time. When PAUSE is pressed, 50 labels print at 6 in. (152 mm) per second.
- While the printer is paused, pressing CANCEL again alters the self test a fourth time. When PAUSE is pressed, 15 labels print at the printer's maximum speed.
- To exit this self test at any time, press and hold CANCEL.

FEED Self Test

This test helps you choose the best darkness setting for your printer.

To perform a FEED self test, complete these steps:

1. Turn Off (O) the printer.
2. Press and hold FEED while turning the power On (I). Hold FEED until the DATA light turns off.

The printer prints a series of labels like the one below at various darkness settings higher and lower than the darkness value shown on the configuration label.



3. Inspect the labels and determine which one has the best darkness setting for your application. This value can be entered into the printer by setting the darkness during the configuration procedure.

The value printed on that label is added to (plus) or subtracted from (minus) the darkness value specified on the configuration label. The resulting numeric value (0 to 30) is the best darkness value for that specific label/ribbon combination.

FEED and PAUSE Self Test

Performing this self test temporarily resets the printer configuration to the factory default values. These values are active only until power is turned off unless you save them permanently in memory.

To perform a FEED and PAUSE self test, complete these steps:

1. Turn Off (O) the printer.
2. Press and hold FEED and PAUSE while turning the power On (I). Hold FEED and PAUSE until the DATA light turns off.

No labels print at the end of this test.

Communications Diagnostics Test

This test is controlled from the front panel display. See *Setting Communications Mode* on page 87. The following illustration shows a typical printout from this test. Turn off the power to exit this self test and return to normal operation.



Note • The communications test label prints upside-down.

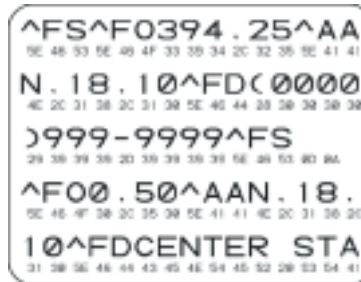

Additional Printer Diagnostics

Additional diagnostic tests are available for this printer. See the *Maintenance Manual* for information about these additional tests.



APPENDIX 10

Specifications

This appendix provides the features of and specifications for the BP THT X-Plus II printers.

Contents

Features	130
Standard Features	130
Print Modes	130
Zebra Programming Language (ZPL II®)	130
Bar Codes	131
Agency Approvals for All Printers	132
Compliance for All Printers	132
General Specifications	133
Electrical Specifications	133
Environmental Conditions for Operation and Storage	134
Print Specifications by Model	135
Ribbon Specifications by Model	136
Label Specifications	137
BP THT 300/600X-Plus II Printers	137
BP THT 360X-Plus II Printers	140

Features

This section lists the standard and optional features for the printer.

Standard Features



Note • Printer specifications are subject to change without notice.

- Thermal transfer and direct thermal printing
- DRAM 16 MB
- USB 2.0 Port
- Real-time Clock
- Advanced Counter

Print Modes

Four different print modes can be used, depending on the printer options purchased.

- **Tear-Off Mode:** Labels are produced in strips.
- **Peel-Off Mode:** Labels are dispensed and peeled from the backing as needed.
- **Cutter Mode:** Labels are printed and individually cut.
- **Rewind Mode:** Labels are rewound internally.

Zebra Programming Language (ZPL II[®])

ZPL features include:

- Downloadable graphics, scalable and bitmap fonts, and label formats
- Object copying between memory areas
- (RAM, memory card, and internal Flash)
- Code page 850 character set
- Adjustable print cache
- Data compression
- Automatic virtual input buffer management
- Format inversion

- Mirror image printing
- Four-position field rotation (0°, 90°, 180°, 270°)
- Slew command
- Controlled via mainframe, mini-computer, PC, portable data terminal
- Programmable quantity with print, pause, and cut control
- Communicates in printable ASCII characters
- Error-checking protocol
- Status message to host upon request
- Serialized fields
- In-spec OCR-A and OCR-B
- UPC/EAN
- User-programmable password

Bar Codes

Types of bar codes include:

- Bar code ratios—2:1, 7:3, 5:2, 3:1
- Codabar (supports ratios of 2:1 up to 3:1)
- CODABLOCK
- Code 11
- Code 39 (supports ratios of 2:1 up to 3:1)
- Code 49 (two-dimensional bar code)
- Code 93
- Code 128 (with subsets A, B, and C and UCC case codes)
- Check digit calculation where applicable
- Data Matrix
- EAN-8, EAN-13, EAN extensions
- ISBT-128
- Industrial 2 of 5
- Interleaved 2 of 5 (supports ratios of 2:1 up to 3:1, Modulus 10 Check Digit)
- LOGMARS
- MaxiCode
- Micro PDF

- MSI
- PDF-417 (2-dimensional bar code)
- PLANET code
- Plessey
- POSTNET
- QR-Code
- RSS code
- Standard 2 of 5
- TLC 39
- UPC-A, UPC-E, UPC extensions

Agency Approvals for All Printers

Approvals include:

- Binational UL 60950 3rd edition/CSA CAN/CSA-C22.2 No. 60950-00 3rd edition
- IEC 950/EN60950
- EN55022:1998 Class B
- EN55024: 1998
- EN61000-3-2,3
- Canadian ICES-003, Class B
- FCC class B
- Argentina 92/98 Phase 3
- Australia AS/NZS 3548
- R.O.C. CNS 13438

Compliance for All Printers

- Complies with FCC class B and Canadian Doc. class A rules
- Carries the CE mark of compliance

General Specifications

The following table gives the general specifications for the printer by model number.

Dimensions	BP THT 300/600X-Plus II	BP THT 360X-Plus II
Height	15.5 in (393.7 mm)	15.5 in. (393.7 mm)
Width	10.37 in. (263.5 mm)	13.15 in. (334.4 mm)
Depth	19.5 in. (495.3 mm)	19.5 in. (495.3 mm)
Weight without options	51 lb. (25 kg)	67 lb. (30.5 kg)

Electrical Specifications

The following table gives electrical specifications for the printers by model number.

Power	BP THT 300/600X-Plus II	BP THT 360X-Plus II
General	90 to 264 VAC; 48 to 62 Hz	90 to 264 VAC; 48 to 62 Hz
Power consumption printing PAUSE test at slowest speed	180 W	220 W
Printer idle	20 W	19 W

Environmental Conditions for Operation and Storage

Environment	Mode	Temperature	Relative Humidity
Operation	Thermal Transfer	41° to 104°F (5° to 40° C)	20 to 85% non-condensing
	Direct Thermal	32° to 104°F (0° to 40° C)	
Storage	Thermal Transfer or Direct Thermal	-40° to 140°F (-40° to 60° C)	5 to 85% non-condensing

Print Specifications by Model

Refer to the key and the table that follows for printer specifications.

Model Specifications Key

This table contains the key for print specifications for the tables that follow.

■	Non-Continuous printing (gap, notch, or hole between labels).
▣	Continuous printing (no gap, notch or hole).
◆	Ladder (rotated) orientation.
◇	Picket fence (nonrotated) orientation.

Specification	BP THT 300X-Plus II	BP THT 600X-Plus II	BP THT 360X-Plus II
H	300 dots/inch (12 dots/mm)	600 dots/inch (24 dots/mm)	300 dots/inch (12 dots/mm)
Dot size (width×length)	0.0033×0.0039 in. (0.84×0.100 mm)	0.0016×0.0016 in. (0.042×0.042 mm)	0.0033×0.0039 in. (0.84×0.100 mm)
First dot location (measured from inside media edge)	0.023 ± 0.035 in. (0.6 ± 0.9 mm)	0.023 ± 0.035 in. (0.6 ± 0.9 mm)	0.10 ± 0.035 in. (2.5 ± 0.89 mm)
Maximum print width	4.09 in. (104 mm)	3.2 in. (81 mm)	6.6 in. (168 mm)
Selectable print speeds (inches per second)	2.4, 3 through 8	1.5, 2 through 4	2.4, 3, 4, 5, 6, 7, 8
Maximum Print length	39 in. (991 mm)■ 100 in. (3810 mm)■	39 in. (991 mm)■ 39 in. (991 mm)■	39 in. (991 mm)■ 100 in. (3810 mm)■
Bar code modulus (X) dimension	3.9 mil to 39 mil◆ 3.33 mil to 33 mil◇	1.6 mil to 16 mil◆ 1.6 mil to 16 mil◇	3.9 mil to 39 mil◆ 3.33 mil to 33 mil◇
Thin film printhead with Element Energy Equalizer (E ³) [®]	Yes	Yes	Yes

Ribbon Specifications by Model

Refer to the table that follows for ribbon specifications for your type of printer.



Note • Match the ribbon to the label width and printhead width that you are using.

- Ribbon must be wound with the coated side out.
- Ribbon should be at least as wide as the labels to protect the printhead from excessive wear.

Specifications	BP THT 300X-Plus II	BP THT 600X-Plus II	BP THT 360X-Plus II
Printhead resolution	300 dots/inch (12 dots/mm)	600 dots/inch (24 dots/mm)	300 dots/inch (12 dots/mm)
Ribbon width Minimum	0.79 in. (20 mm)	0.79 in. (20 mm)	2.0 in. (51 mm)
Ribbon width Maximum	4.33 in. (110 mm)	3.40 in. (87 mm)	6.7 in. (170 mm)
Standard length with 2:1 label to ribbon ratio	984 ft (300 m)	984 ft (300 m)	984 ft (300 m)
Standard length with 3:1 label to ribbon ratio	1476 ft (450 m)	1476 ft (450 m)	1476 ft (450 m)
Ribbon core inside diameter	1.0 in. (25.4 mm)	1.0 in. (25.4 mm)	1.0 in. (25.4 mm)
Maximum ribbon roll outside diameter	3.2 in. (81.3 mm)	3.2 in. (81.3 mm)	3.2 in. (81.3 mm)

Label Specifications

X-Plus II printers need the correct size and type of labels for best performance. The tables that follow give you the specifications you need.

BP THT 300/600X-Plus II Printers

! **Important** • Media registration and minimum label length are affected by label type and width, ribbon type, print speed, and printer mode of operation. Performance improves as these factors are optimized. Brady recommends qualifying any application with thorough testing.

Label Specification Key

This table contains the key for the label modes, dimensions, and directions:

T	Tear-Off
P	Peel-Off
C	Cutter
R	Rewind
□	Minimum
■	Maximum
●	Preferred

Specifications	BP THT 300X-Plus II	BP THT 600X-Plus II
Minimum label length	0.7 in. (18 mm) T	0.7 in. (18 mm) T
	0.5 in. (13 mm) P	0.5 in. (13 mm) P
	1.5 in. (38 mm) C	1.5 in. (38 mm) C
	0.25 in. (6 mm) R	0.25 in. (6 mm) R
Total media width (label + backing, if any)	0.79 in. (20 mm) □	0.79 in. (20 mm) □
	4.5 in. (114 mm) ■	4.5 in. (114 mm) ■

Specifications

Label Specifications

Specifications	BP THT 300X-Plus II	BP THT 600X-Plus II
Total thickness (includes backing, if any)	0.003 in. (0.076 mm)□ 0.012 in. (0.305 mm)■	0.003 in. (0.076 mm)□ 0.012 in. (0.305 mm)■
Cutter maximum full-width media thickness	0.009 in. (0.23 mm)	Does not apply
Roll media core inside diameter	3 in. (76 mm)	3 in. (76 mm)
Maximum roll diameter on 3 in. (76 mm) core	8.0 in. (203 mm)	8.0 in. (203 mm)
Interlabel gap	0.079 in. (2 mm)□ 0.157 in. (4 mm)■ 0.118 in. (3 mm)●	0.079 in. (2 mm)□ 0.157 in. (4 mm)■ 0.118 in. (3 mm)●
Maximum internal fanfold media pack size (label + backing) L × W × H	8.0×5.5×4.5 in. (203×40×114 mm)	8.0×7.1×4.5 in. (203×180×114 mm)
Ticket/tag sensing notch L × W	0.12×0.25 in. (3×6 mm)	0.12×0.25 in. (3×6 mm)
Ticket/tag sensing hole diameter	0.125 in. (3 mm)	0.125 in. (3 mm)
Label registration tolerance (vertical)	± 0.06 in. (± 1.5 mm)	± 0.06 in. (± 1.5 mm)
Label registration tolerance (horizontal)	± 0.06 in. (± 1.5 mm)	± 0.06 in. (± 1.5 mm)

Black Mark Sensing Only

Specifications	BP THT 300X-Plus II	BP THT 600X-Plus II
Mark length (measuring parallel to label/tag edge)	0.12 in. (3 mm) □ 0.43 in. (11 mm) ■	0.12 in. (3 mm) □ 0.43 in. (11 mm) ■
Mark width (measuring to perpendicular label/tag edge)	0.43 in. (11 mm) □ Full media width ■	0.43 in. (11 mm) □ Full media width ■
Mark location	within 0.040 in. (1 mm) of the inside media edge	within 0.040 in. (1 mm) of the inside media edge
Mark density in Optical Density Unit (ODU)	>1.0	>1.0

BP THT 360X-Plus II Printers

! **Important** • Media registration and minimum label length are affected by label type and width, ribbon type, print speed, and printer mode of operation. Performance improves as these factors are optimized. Brady recommends qualifying any application with thorough testing.

Label Specification Key

This table contains the key for the label modes, dimensions, and directions:

T	Tear-Off
P	Peel-Off
C	Cutter
R	Rewind
□	Minimum
■	Maximum
●	Preferred

Specifications	BP THT 360X-Plus II
Minimum label length ^H	0.7 in. (18 mm) T
	0.5 in. (13 mm) P
	1.5 in. (38 mm) C
	0.25 in. (6 mm) R
Total media width (label + backing, if any)	2.00 in. (51 mm) □
	7.1 in. (180 mm) ■
Total thickness (includes backing, if any)	0.003 in. (0.076 mm) □
	0.012 in. (0.305 mm) ■
Cutter maximum full-width media thickness	0.007 in. (0.18 mm)
Roll media core inside diameter	3 in. (76 mm)
Maximum roll diameter	8.0 in. (203 mm)
Inter-label gap	0.079 in. (2 mm) □
	0.118 in. (3 mm) ■

Specifications	BP THT 360X-Plus II
Preferred inter-label gap	Maximum inter-label gap = 2 × (label length for which you have calibrated the printer) + 1 in. (25.4 mm)
Maximum internal fanfold media pack size (label + backing) L×W×H	8.0×7.1×4.5 in. (203×114×114 mm)
Ticket/tag sensing notch L×W	0.12×0.25 in. (3×6 mm)
Ticket/tag sensing hole diameter	0.125 in. (3 mm)
Effective leading edge registration accuracy (vertical)	± 0.060 in. (± 1.5 mm)
Effective leading edge registration accuracy (horizontal)	± 0.060 in. (± 1.5 mm)

Black Mark Sensing Only

Specifications	BP THT 360X-Plus II
Mark length (measuring parallel to label or tag edge)	0.12 in. (3 mm) □ 0.43 in. (11 mm) ■
Mark width (measuring to perpendicular label or tag edge)	0.43 in. (11 mm) □ Full media width ■
Mark location	Marks must be located within 0.040 in. (1 mm) of the inside media edge.
Mark density in Optical Density Unit (ODU)	>1.0

Index

A

about this document	xxi
adjustments	
LCD	96
left position	91
lower media sensor	38
print darkness	76
print speed	77
printhead toggle pressure	39
sensors	34
tear-off position	77
upper media sensor	36
agency approvals	132
alert setting	80
applicator port setting	94
auto-calibration	33

B

backfeed setting	90
backing removal	53
bar codes	
list available codes	81
types of codes	131
baud setting	85
before you begin setup	10
bitmap scaling factor	96

black mark media	
definition	17
setting sensor type	78
when to clean sensor	102
BP THT 300X-Plus II	
black mark specifications	139
label specifications	137
BP THT 360X-Plus II	
black mark specifications	142
label specifications	140
BP THT 600X-Plus II	
black mark specifications	139
label specifications	137
Brady support	xx
BradyConnect PrintServer II	15
buttons on front panel	4

C

cable requirements	16
calibration	
media and ribbon sensor	34, 84
methods	33
setting for head close	89
setting for media power up	89
Canadian DOC compliance	vi
CANCEL self test	124
check firmware version	33
CHECK RIBBON light on	34

checklist	
before you begin	10
troubleshooting	112
CLEAN HEAD NOW message	116
cleaning	
cutter	108
exterior of printer	103
interior	103
printhead and platen roller	103
recommended schedule	102
sensors	105
snap plate	107
communication interfaces	
overview and location	15
types of connections	56
communications diagnostics test	
sample printout	127
selecting	87
communications problems	121
CompactFlash card	
initialize	82
installation	68
compliance	132
components	6
configuration	
enter setup mode	72
leave setup mode	73
configuration label	
print during CANCEL self test	124
printing after loading printer	31
printing using List Setup command	81
sample	31
connect printer to power source	13
contact information	xx
continuous media	
defined	17
setting media type	78
control prefix setting	88
creases on labels	120
create ribbon leader	26
customer support	xx
cutter	
cleaning	108
CUTTER JAMMED message	117
set up Cutter Mode	45
set up Rewind Mode with cutter	50
when to clean	102
D	
darkness setting	76
data bits setting	85
data cable requirements	16
data connections	
RS-232	60
RS-422/RS-485	63
data ports	56
data source	
communication interface location	15
communication interfaces	56
provide connections	12
date setting	96
DB-9 to DB-25 connection	61
default gateway setting	99
default password	75
delimiter character setting	88
diagnostics	123
direct connection to a computer	60
direct thermal transfer mode	
setting	78
disable password protection	75
display language selection	97
document conventions	
cautions, notes, examples	xxii
command line	xxii
file names and directories	xxii
hot links	xxii
illustration callouts	xxiii
document organization	xxi
dpi format conversion	96
E	
Early Warning setting	80
electrical noise	16
electrical specifications	133

- enter setup mode 72
 - environmental specifications 134
 - error messages 113
 - exterior cleaning 103
- F**
- fanfold media loading 24
 - FCC compliance v
 - features 130
 - FEED and PAUSE self test 127
 - FEED self test 126
 - firmware version 33
 - Flash memory 83
 - fonts
 - listing 81
 - using CompactFlash card 68
 - using PCMCIA card 66
 - format convert setting 96
 - format list 81
 - format prefix setting 88
 - front panel
 - buttons 4
 - enter setup mode 72
 - illustration 3
 - LCD error messages 113
 - LCD setup messages 76
 - leave setup mode 73
 - lights 5
 - fuse replacement 109
- G**
- gray lines on labels 119
- H**
- HEAD COLD message 116
 - HEAD ELEMENT BAD message 114
 - HEAD OPEN message 114
 - HEAD TOO HOT message 115
 - host handshake setting 86
- I**
- IBM Twinax or Coax option 15
 - idle display setting 96
 - image not sharp 119
 - images list 81
 - initialize Flash memory 83
 - initialize memory card 82
 - inspect the printer 11
 - interior cleaning 103
 - international safety organizations 14
 - IP settings
 - default gateway 99
 - IP address 98
 - IP resolution 98
 - protocols 98
 - subnet mask 99
- L**
- label backing removal 53
 - label length maximum setting 79
 - label specifications by model 137
 - label top
 - printer cannot detect 122
 - setting 90
 - label-available sensor
 - location 105
 - when to clean 102
 - labels did not print 121
 - labels per roll setting 81
 - language selection 97
 - LCD messages
 - adjust LCD settings 96
 - error messages 113
 - language selection 97
 - setup mode 76
 - leave setup mode 73
 - liability vi
 - light or no printing 119
 - lights on front panel 5
 - list settings
 - all settings 82
 - bar codes 81
 - fonts 81
 - formats 81
 - images 81
 - setup 81

load the printer
 load fanfold media 24
 load roll media 22
 ribbon 26
 long calibration 33
 lower media sensor adjustment 38

M

mark LED setting 95
 Mark Med S. setting 95
 maximum label length setting 79
 media
 label specifications by model 137
 load fanfold media 24
 load roll media 22
 media LED setting 95
 media low warning 80
 setting labels per roll 81
 setting media type 78
 types of media 17
 media and ribbon sensor calibration
 procedure 34, 84
 when to perform 34
 media path cleaning 102
 media power up setting 89
 Media S. setting 95
 media sensor
 adjustment 36
 location 106
 print media sensor profile 83
 sensor sensitivity calibration 33
 memory card installation
 CompactFlash card 68
 PCMCIA card 66
 modem connection 62

N

network ID setting 87
 non-continuous media
 black mark 17
 setting media type 78
 web media 18

O

operating conditions 12
 OUT OF MEMORY message 117

P

PAPER OUT message 113
 parallel port
 location 15
 pin configuration 57
 setting parallel communications 85
 settings 56
 parity setting 86
 passwords
 default 75
 disable 75
 entering 74
 PAUSE self test 125
 PCMCIA card
 initialize 82
 installation 66
 peel-off bar cleaning 102
 Peel-Off Mode 43
 pin configuration
 parallel port 57
 serial port 59
 platen roller
 cleaning 103
 when to clean 102
 ports 56
 power cord specifications 13
 power source 13
 Power-On Self Test (POST) 123
 print configuration label
 CANCEL self test 124
 List Setup command 81
 when printer is loaded 31
 print darkness setting 76

print modes		printer settings	
Cutter Mode	45	applicator port	94
features	130	backfeed	90
Peel-Off Mode	43	baud	85
Rewind Mode	47	configuration label as baseline	31
Rewind Mode with Cutter option	50	control prefix	88
selecting	42, 77	data bits	85
Tear-Off Mode	22	date	96
print quality		delimiter character	88
effect of printhead toggle pressure	39	Early Warning	80
troubleshooting problems	118	format convert	96
print speed setting	77	format prefix	88
print width setting	79	head resistor	93
printer components	6	head test count	92
printer diagnostics	123	host handshake	86
printer operation	21	idle display	96
printer self tests	123	IP settings	98
		label top	90
		labels per roll	81
		language	97
		LCD	96
		left position	91
		maximum label length	79
		media type	78
		network ID	87
		parallel communications	85
		parity	86
		passwords	74
		print darkness	76
		print method	78
		print speed	77
		print width	79
		protocol	86
		resynch mode	95
		ribbon length	81
		saving	73
		sensor type	78
		serial communications	85
		setting through front panel	72
		start print signal	94
		time	97
		verifier port	93
		ZPL mode	89

printer setup
 before you begin 10
 load the printer 22

printhead
 cleaning 103
 early warning message 80
 head close setting 89
 head resistor value setting 93
 head test count setting 92
 pressure adjustment 39
 when to clean 102

PrintServer II settings
 default gateway 99
 IP address 98
 IP protocols 98
 IP resolution 98
 subnet mask 99

product improvements v

proprietary statement v

protocol setting 86

R

related documents xxv

relative humidity requirements 12

remove backing from rewind spindle 53

remove used ribbon 30

replace fuse 109

report shipping damage 11

reship the printer 11

resynch mode setting 95

Rewind Mode 47

Rewind Mode with Cutter option 50

rewind plate installation 48

rewind spindle 53

ribbon
 CHECK RIBBON light on 34
 create ribbon leader 26
 load 26
 removal 30
 RIBBON IN message 115
 ribbon LED setting 95
 ribbon low warning 80
 Ribbon Out message 113
 setting length 81
 specifications 136
 troubleshooting wrinkles 120
 when used 19

Ribbon S. setting 95

ribbon sensor
 calibration procedure 84
 cleaning 105
 location 105
 sensitivity calibration 33
 when to clean 102

roll media loading 22

routine maintenance 101

RS-232 interface connections 60

RS-422/RS-485 interconnections 63

RTC (Real-time clock) setting
 date 96
 time 97

S

schedule for cleaning 102

select a printer site 12

selecting a print mode 42

self tests
 CANCEL 124
 FEED 126
 FEED and PAUSE 127
 how to perform additional tests 123
 PAUSE 125
 Power-On Self Test (POST) 123

Sensor Profile calibration
 description 33
 procedure 83

sensors	
adjusting	34
cleaning	105
label-available sensor location	105
lower media sensor adjustment	38
media and ribbon sensor calibration	34
ribbon sensor location	105
setting sensor type	78
transmissive (media) sensor adjustment	36
transmissive (media) sensor location	106
upper media sensor adjustment	36
serial port	
location	15
pin configuration	59
setting serial communications	85
settings	58
setup checklist	10
setup mode	
enter setup mode	72
LCD messages	76
leave setup mode	73
shipping	
report damage	11
reship the printer	11
short calibration	33
site requirements	12
snap plate	
cleaning	107
when to clean	102
spacing requirements	12
specifications	
by model number	135
electrical	133
environmental	134
general	133
power cord	13
ribbon	136
standard data ports	56
standard features	130
start print signal setting	94
store the printer	11
subnet mask setting	99
support	xx
surface for the printer	12
T	
take label setting	95
Tear-Off Mode	
load the printer	22
tear-off bar cleaning	102
tear-off position adjustment	77
temperature requirements	12
thermal transfer mode	
load ribbon	26
setting	78
time setting	97
toggle pressure adjustment	39
top of label	
printer cannot detect	122
setting	90
transmissive (media) sensor	
adjustment	36
location	106
when to clean	102
troubleshooting	
CHECK RIBBON light on	34
checklist	112
communications problems	121
LCD error messages	113
non-continuous labels treated as continuous	34
print quality problems	118
printer diagnostics	123
wrinkled ribbon	120
types of media	17
U	
unpack the printer	11
upgrade firmware	33
upper media sensor adjustment	36
USB 2.0 port	
location	15
settings	64
V	
verifier port setting	93
vertical lines on labels	119

W

web media
 definition 18
 setting sensor type 78
Web S. setting 95
wireless card socket option 15
wrinkled ribbon 120

Z

ZPL Programming Language
 features 130
 ZPL mode setting 89



Brady Worldwide Identification Solutions

6555 West Good Hope Road

P.O. Box 2131

Milwaukee, WI 53201-2131

Telephone: +1 800.537.8791

Facsimile: +1 800.292.2289



Customer Order # 13383-12
Manufacturer Part # 13383LB-12 Rev. 1
© 2004 Brady Worldwide Inc.