



# TEMI 300

## INSTRUCTION MANUAL

TEMPERATURE • HUMIDITY  
PROGRAMMABLE CONTROLLER

---

## Contents ( I : User's Guide)

1. Safety Guide .....	4
2. Control Keys and Display .....	6
3. Basic Flow Map .....	7
4. Setting Up Parameter in Each Group .....	9
4.1 FIX Mode .....	9
4.2 PROG Run Screen .....	10
4.3 MAIN Screen Operation & Setting .....	12
4.3.1 Function .....	12
4.3.2 PROGRAM .....	15
4.3.3 RESERVE .....	18
4.3.4 GRAPH .....	19
4.4 SETUP Screen .....	20
4.4.1 INPUT .....	20
4.4.2 OUTPUT .....	22
4.4.3 ON/OFF .....	24
4.4.4 Inner Signal(IS) .....	26
4.4.5 ALARM .....	27
4.4.6 DO CONFIG .....	29
4.4.7 BIAS .....	32
4.4.8 DI NAME .....	34
4.4.9 PASSWORD .....	35
4.4.10 PID SET .....	36
4.5 TROUBLE SHOOTING .....	38

5. Installation ..... 39

    5.1 Dimension & Panel Cutting Size ..... 39

    5.2 How to Install Mount ..... 40

    5.3 Power Cable Specification ..... 41

    5.4 Terminal Specification ..... 41

    5.5 Terminal Arrangement and External Wiring ..... 42

    5.6 Grounding and Power Cable Connection ..... 43

    5.7 Analog Input Connection ..... 43

    5.8 Analog Output Connection ..... 44

    5.9 External Contact Output Connection(RELAY) ..... 45

    5.10 External Contact Input Connection(DI) ..... 45

    5.11 Use an Auxiliary Relay ..... 45

Table 1 : Alarm Type ..... 28

Figure 1 : Overshoot Suppressing by Fuzzy Function ..... 12

Figure 2 : Ex. SLOPE Setting ..... 12

Figure 3 : WAIT – Ex. Wait Function Release Within WTM ..... 17

Figure 4 : WAIT – Ex. PV can't enter the wait zone within WTM ..... 17

Figure 5 : AT GAIN ..... 22

Figure 6 : Ex. ON/OFF MODE ..... 25

Figure 7 : Ex. Inner Signal Zone ..... 26

Figure 8 : Alarm Operation ..... 28

Figure 9 : Ex. UP, SOAK, DOWN ..... 29

Figure 10 : Ex. Piece Bias Formula ..... 32

Figure 11 : PID Group ..... 36

## Contents ( II : Communication User’s Guide)

1.	Communication Overview .....	47
2.	Wiring for Communication .....	48
2.1	RS485 Interface Connection with TEMI 300 .....	48
3.	Configuration of Command .....	49
3.1	Consist of Command .....	49
3.2	Type of Command .....	50
3.3	Error Response .....	50
3.4	RSD Command .....	51
3.5	RRD Command .....	52
3.6	WSD Command .....	53
3.7	WRD Command .....	54
3.8	STD Command .....	55
3.9	CLD Command .....	56
4.	D-REGISTER .....	57
4.1	PROCESS .....	58
4.2	FUNCTION .....	60
4.3	RESERVATION .....	62
4.4	IS/ALARM .....	63
4.5	PID .....	64
4.6	OUTPUT .....	65
4.7	INPUT .....	67
4.8	PROGRAM .....	68
4.9	ON/OFF .....	69
<u>Enclosure D-Register</u> .....		70

## 1. Safety Guide

The following safety symbols are used in this manual

(A) If this symbol is marked on the product, the operator must investigate the explanation given in this manual to protect injury or death to personnel or damage to instrument.



CAUTION

(1) For Production : it should be marked when operator must refer the explanation in the manual to avoid loss of life or damage to instrument.

(2) For Instruction Manual : it marks to avoid operator's loss of life and injury that may result comes from Electric Shock.

(B) Protective Ground Terminal



It marks the terminal must be connected to Ground prior to operating the equipment.

(C) It marks additional Information on the operation and features of the product.



NOTE

(D) It marks for further information on the current topic and pages



CAUTION

### Precautions on this instruction Manual

- (1) This Manual should be passed on the end User and keep a suitable place for operator to study and check the function of the product.
- (2) Operator should carefully study, understand how to operate this product before
- (3) This manual is describing the functions of the product. We, Samwontech, does not warrant that the functions will suit a particular purpose.
- (4) Under absolutely no circumstance may the contents of this manual in part or in whole be transcribed or copied without permission.
- (5) All contents of this manual has been made to ensure accuracy in the preparation, However, should any errors or omissions come to the attention of the user, feel free to contact our sales representatives or our sales office



CAUTION

### Regarding Safety and Unauthorized Modification

- (1) In order to protect this product and the system controlled by it against damage and ensure its safe use, make certain that all of the safety instructions and precautions in this manual are strictly adhered to.
- (2) We, Samwontech, are not guarantee safety if the products are not handled according to this instruction manuals
- (3) If separate protection or safety circuits are to be installed for this product or the system which is controlled by this product, ensure that such circuits are installed external to the product.
- (4) Don't try to make modifications or additions internal to the product. It may becomes electric shock, burn or out of order.
- (5) In case of replacement parts or consumables of the product, must call to our sales office.
- (6) Protect this product from moisture. It may becomes out of order.
- (7) Protect any kind of shock and vibration to the product. It may becomes product defects and out of order



CAUTION

### Regarding an exemption from responsibility

- (1) Samwontech co. Ltd does not make any warranties regarding the product except Warranty conditions those mentioned in this manual.
- (2) We assumes no liability to any party for any loss or damage, direct or indirect, caused by the use or any unpredictable defect of the product.



### Regarding the production Quality Assurance.

- (1) The guaranteed period of the production quality assurance is (1) one year after end user buy it and it will be free to fix defected product under regular usage described by this manual.
- (2) It will be charged to fix defected product after warranty period. This charge will announced by our actual cost to be calculated during the fixing time.
- (3) It will be charging even if within warranty period as following events.
  - (3.1) Defect by operator and user's default.(forget password, production initialize)
  - (3.2) Natural disaster.(fire, water flow etc)
  - (3.3) Additional shift after 1st installed.
  - (3.4) Improperly repaired, or altered, modified in anyway.
  - (3.5) Power failure in unstable power condition.
- (4) Feel free to contact our sales office whenever it need to make A/S.



### Environmental precautions for installation.

- (1) Be sure to operate the controller installed on a panel to prevent electric shock.
- (2) To install the controller, do select a location where;

- No one may accidentally touch terminal.
- Mechanical vibrations are minimal.
- No corrosive gas is prevent.
- Temperature fluctuation is minimal.
- Temperature can be maintained. (50 °C below / 10 °C over)
- No direct heat radiation is present.
- No magnetic disturbances are caused
- No water is splashed.
- No flammable materials are around.
- No wind blows. (prevent Dust with salt)
- No ultraviolet rays are present.
- Pollution Degree 2
- Installation Category II
- Do not block openings
- If the equipment is used in a manner not specified by the manufacturer, the protection provided by the equipment may be impaired.
- A switch or circuit-breaker acting as the disconnect device shall be included in the application or the building installation



### Precautions of Controller Mounting.

- Keep the input circuit wiring as far as possible away from power and ground circuit.
- Keep the controllers in 10°C ~ 50°C/ 20 % ~ 90 % RH,  
Warming up needed to use controller when temperature is below 10°C in advance.
- Do not mount front panel facing downward.
- To prevent electric shock, be sure to turn off and the source circuit breaker before wiring.
- The power consumptions are 100-240VAC, 50/60Hz, 15VAmax and operate without power switching in advance.
- No work in wet hands ( it caused electric shock)
- Follow operation by precaution in the manual to avoid fire, electric shock, loss of life etc.
- Requested to follow mounting and operation methods just indicated in this manual.
- Refer the way of grounding connection, however, keep away for grounding to Gas pipe, water pipe, lightening rod etc.
- Be sure not to power connection before finishing of wiring between each contact point.
- Not close and wrapping the heat hole in back case of controller.

## 2. Control Keys and Display

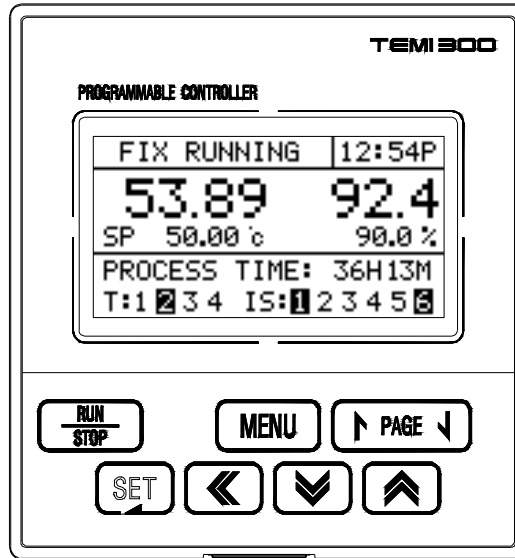

○ Control Keys

Key	Contents
	Run / Stop controller (Pressing the key at least 3 sec.)
	Switching between running and main menu page Change the up level page on the parameter setting page
	Switches to next page on the same level
	Switches to previous page on the same level
	Change to page on the menu Switching between parameters or registering parameter settings
	Move left / right on the parameter setting page Shifting position to modify value
	Decrease the value of parameters Change to other available items Move between GROUP
	Increase the value of parameters Change to other available items Move between GROUP

3. Basic Flow Map

POWER ON

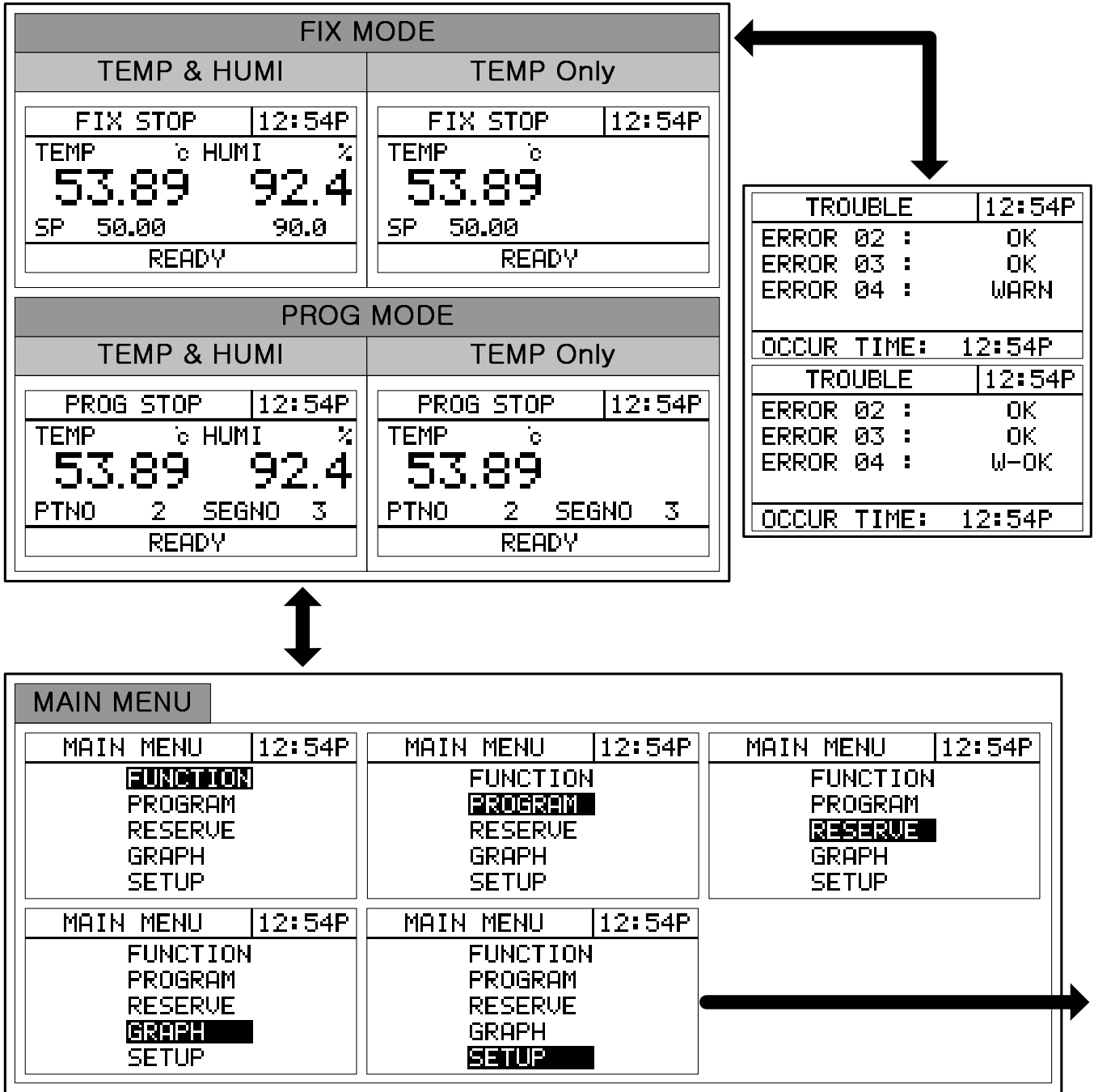



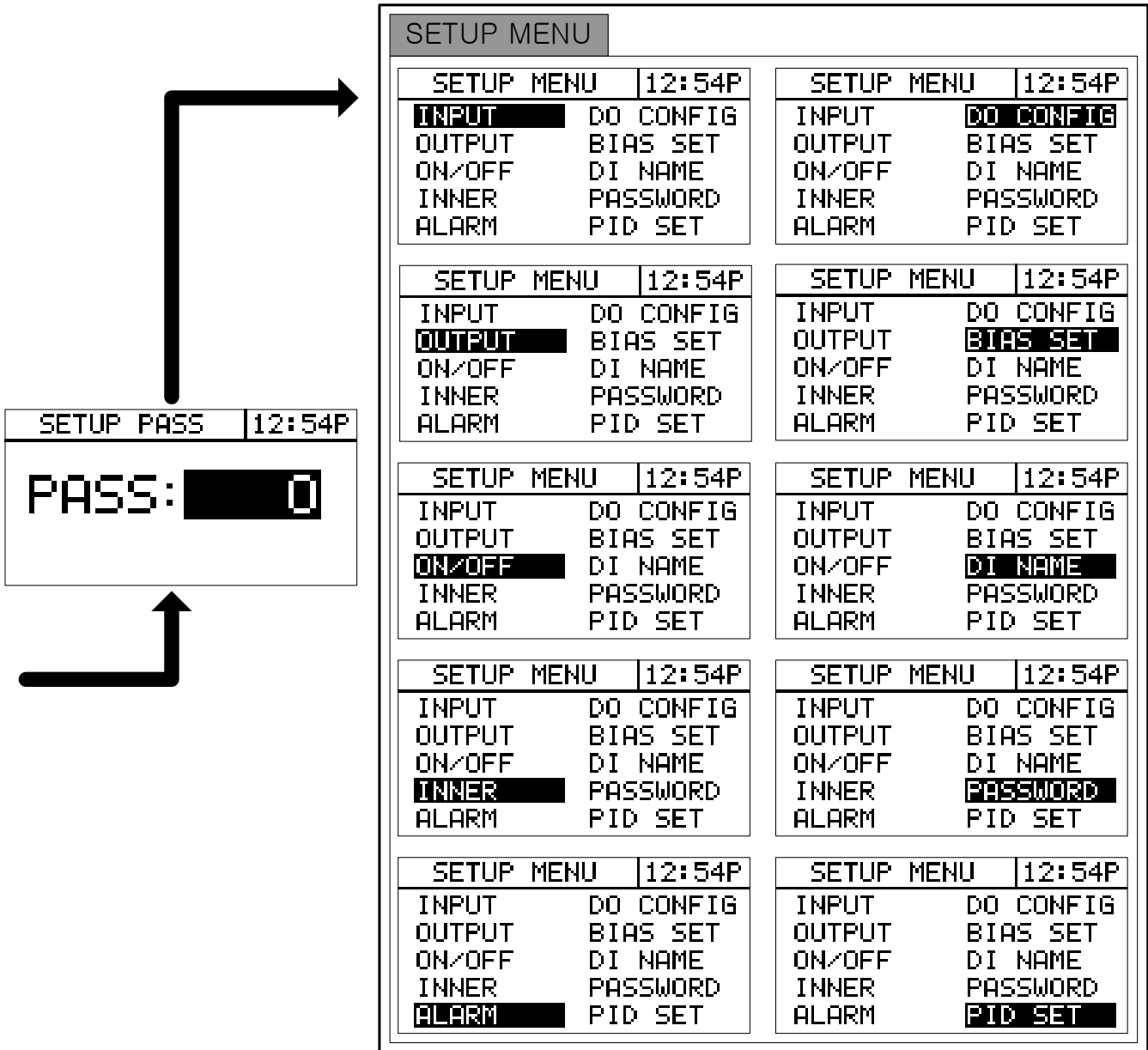

## 4. Setting Up Parameter in Each Group

### 4.1 FIX Mode

FIX STOP	12:54P
TEMP °C	HUMI %
53.89	92.4
SP 50.00 °C	90.0 %
READY	

FIX Mode is controlling Temperature & Humidity with fixed SP  
 FIX STOP : Stop state  
 SP : Set point (Setting by "SET" key)  
 READY : Ready to running  
 Start running by "RUN/STOP" key

FIX RUNNING	12:54P
53.89	92.4
SP 50.00 °C	90.0 %
PROCESS TIME: 36H13M	
T:1 3 4 IS:1 2 3 4 5 6	

FIX running 1st screen  
 FIX RUNNING : Fix running state  
 PROCESS TIME : Running time  
 T : State of ON/OFF  
 IS : State of Inner Signal

FIX RUNNING	12:54P
PV 48.06 °C	90.0 %
SP 50.00 °C	90.0 %
MV 50.00 %	42.7 %
RUN PID NUMBER : 5	
T:1 3 4 IS:1 2 3 4 5 6	

FIX running 2nd screen  
 PV : Process value of temperature & humidity  
 MV : Manipulate value  
 RUN PID NUMBER : Running PID Number  
 (Display "TEMP, HUMI AUTO TUNING" when the auto tuning)

Symbol	Parameter	Range	Display	Unit	Default	Edit
T.SP	TEMP SP	T.EU(0.0 ~ 100.0%)	Always	T.EU	T.EU (0.0%)	O
H.SP	HUMI SP	H.EU(0.0 ~ 100.0%)	When HUMI OPER=ON	H.EU	H.EU (0.0%)	O
P.TM	PROCESS TIME	00H00M ~ 99H59M	Always	TIME	00H00M	X
T.MV	TEMP MV	0.0 ~ 100.0	Always	%	0.0%	X
H.MV	HUMI MV	0.0 ~ 100.0	When HUMI OPER=ON	%	0.0%	X
R.PID	RUN PID NUMBER	1 ~ 6	Always	ABS	x	X

### 4.2 PROG Mode

<table border="1"> <tr> <td>PROG STOP</td> <td>12:54P</td> </tr> <tr> <td>TEMP °C HUMID %</td> <td></td> </tr> <tr> <td><b>53.89</b>    <b>92.4</b></td> <td></td> </tr> <tr> <td>PTNO 2    SEGNO 3</td> <td></td> </tr> <tr> <td>READY</td> <td></td> </tr> </table>	PROG STOP	12:54P	TEMP °C HUMID %		<b>53.89</b> <b>92.4</b>		PTNO 2    SEGNO 3		READY		<p>PROG Mode is controlling Temperature &amp; Humidity with programmed data                  PTNO : Set pattern No.(Set with "SET" key)                  SEGNO : Start segment No.                  READY : Ready to running                  Start running by "RUN/STOP" key</p>		
PROG STOP	12:54P												
TEMP °C HUMID %													
<b>53.89</b> <b>92.4</b>													
PTNO 2    SEGNO 3													
READY													
<table border="1"> <tr> <td>PROG RUNNING</td> <td>12:54P</td> </tr> <tr> <td>TEMP °C HUMID %</td> <td></td> </tr> <tr> <td><b>53.89</b>    <b>92.4</b></td> <td></td> </tr> <tr> <td>SP 50.00 °C    90.0 %</td> <td></td> </tr> <tr> <td>PROCESS TIME: 36H13M</td> <td></td> </tr> <tr> <td>PT: 2 SEG: 5 RPT: 0</td> <td></td> </tr> </table>	PROG RUNNING	12:54P	TEMP °C HUMID %		<b>53.89</b> <b>92.4</b>		SP 50.00 °C    90.0 %		PROCESS TIME: 36H13M		PT: 2 SEG: 5 RPT: 0		<p>PROG running 1st screen                  PROG RUNNING : Prog running state                  PROCESS TIME : Running time                  RPT : Repeat pattern No.</p>
PROG RUNNING	12:54P												
TEMP °C HUMID %													
<b>53.89</b> <b>92.4</b>													
SP 50.00 °C    90.0 %													
PROCESS TIME: 36H13M													
PT: 2 SEG: 5 RPT: 0													
<table border="1"> <tr> <td>PROG RUNNING</td> <td>12:54P</td> </tr> <tr> <td>PV 48.06 °C    90.0 %</td> <td></td> </tr> <tr> <td>SP 50.00 °C    90.0 %</td> <td></td> </tr> <tr> <td>MV 50.00 %    42.7 %</td> <td></td> </tr> <tr> <td>R.PID:5    RM.TM: 0H13M</td> <td></td> </tr> <tr> <td>T:1 2 3 4    IS: 1 2 3 4 5 6</td> <td></td> </tr> </table>	PROG RUNNING	12:54P	PV 48.06 °C    90.0 %		SP 50.00 °C    90.0 %		MV 50.00 %    42.7 %		R.PID:5    RM.TM: 0H13M		T:1 2 3 4    IS: 1 2 3 4 5 6		<p>PROG running 2nd screen                  R.PID : Running PID No.(Figure3)                  RM.TM : Remained running time</p>
PROG RUNNING	12:54P												
PV 48.06 °C    90.0 %													
SP 50.00 °C    90.0 %													
MV 50.00 %    42.7 %													
R.PID:5    RM.TM: 0H13M													
T:1 2 3 4    IS: 1 2 3 4 5 6													
<table border="1"> <tr> <td>PROG RUNNING</td> <td>12:54P</td> </tr> <tr> <td>PV 48.06 °C    90.0 %</td> <td></td> </tr> <tr> <td>SP 50.00 °C    90.0 %</td> <td></td> </tr> <tr> <td>MV 100.00 %    42.7 %</td> <td></td> </tr> <tr> <td>HOLDING PT/SG: 2 / 3</td> <td></td> </tr> <tr> <td>T:1 2 3 4    IS: 1 2 3 4 5 6</td> <td></td> </tr> </table>	PROG RUNNING	12:54P	PV 48.06 °C    90.0 %		SP 50.00 °C    90.0 %		MV 100.00 %    42.7 %		HOLDING PT/SG: 2 / 3		T:1 2 3 4    IS: 1 2 3 4 5 6		<p>PROG running 3rd screen                  When HOLD ON, display held PT and SEG                  When HOLD OFF, display running state</p>
PROG RUNNING	12:54P												
PV 48.06 °C    90.0 %													
SP 50.00 °C    90.0 %													
MV 100.00 %    42.7 %													
HOLDING PT/SG: 2 / 3													
T:1 2 3 4    IS: 1 2 3 4 5 6													
<table border="1"> <tr> <td>PROG RUNNING</td> <td>12:54P</td> </tr> <tr> <td>HOLD:            OFF</td> <td></td> </tr> <tr> <td>STEP:            OFF</td> <td></td> </tr> <tr> <td>PTNO: 2    SEGNO: 3</td> <td></td> </tr> <tr> <td>T: DOWN    H: SOAK</td> <td></td> </tr> </table>	PROG RUNNING	12:54P	HOLD:            OFF		STEP:            OFF		PTNO: 2    SEGNO: 3		T: DOWN    H: SOAK		<p>PROG running 4th screen                  HOLD : "HOLD ON" or "HOLD OFF" with presents SP                  STEP : Stop to present segment then step to next segment                  DOWN : Going down zone                  SOAK : Gong stable zone                  UP : Going up zone</p>		
PROG RUNNING	12:54P												
HOLD:            OFF													
STEP:            OFF													
PTNO: 2    SEGNO: 3													
T: DOWN    H: SOAK													
<table border="1"> <tr> <td>PROG STOP</td> <td>12:54P</td> </tr> <tr> <td>TEMP °C HUMID %</td> <td></td> </tr> <tr> <td><b>53.89</b>    <b>92.4</b></td> <td></td> </tr> <tr> <td>PTNO 2    SEGNO 3</td> <td></td> </tr> <tr> <td>PATTERN END</td> <td></td> </tr> </table>	PROG STOP	12:54P	TEMP °C HUMID %		<b>53.89</b> <b>92.4</b>		PTNO 2    SEGNO 3		PATTERN END		<p>PATTERN END : Finished running</p>		
PROG STOP	12:54P												
TEMP °C HUMID %													
<b>53.89</b> <b>92.4</b>													
PTNO 2    SEGNO 3													
PATTERN END													

Symbol	Parameter	Range	Display	Unit	Default	Edit
T.SP	TEMP SP	T.EU(0.0 ~ 100.0%)	Always	T.EU	T.EU (0.0%)	X
H.SP	HUMI SP	H.EU(0.0 ~ 100.0%)	When HUMI OPER=ON	H.EU	H.EU (0.0%)	X
PTNO	PATTERN NUMBER	0 ~ 10	Always	ABS	0	O*note
SEGNO	SEGMENT NUMBER	0~100(00)	Always	ABS	0	X
P.TM	PROCESS TIME	00H00M ~ 99H59M	Always	TIME	00H00M	X
RPT	PATTERN REPEAT	0 ~ 999	Always	ABS	0	X
T.MV	TEMP MV	0.0 ~ 100.0	Always	%	0.0%	X
H.MV	HUMI MV	0.0 ~ 100.0	When HUMI OPER=ON	%	0.0%	X
R.PID	RUN PID NUMBER	1 ~ 6	Always	ABS	X	X
RM.TM	REMAIN TIME	00~99	Always	TIME	X	X
HOLD	HOLD	OFF, ON	Always	ABS	OFF	O
STEP	STEP	OFF, ON	Always	ABS	OFF	O

\*note : Edit is impossible while PROG  
operating

### 4.3 MAIN Screen Operation & Setting

#### 4.3.1 FUNCTION

<table border="1"> <tr> <td>MAIN MENU</td> <td>12:54P</td> </tr> <tr> <td><b>FUNCTION</b></td> <td></td> </tr> <tr> <td>PROGRAM</td> <td></td> </tr> <tr> <td>RESERVE</td> <td></td> </tr> <tr> <td>GRAPH</td> <td></td> </tr> <tr> <td>SETUP</td> <td></td> </tr> </table>	MAIN MENU	12:54P	<b>FUNCTION</b>		PROGRAM		RESERVE		GRAPH		SETUP		<p>MENU KEY → FUNCTION → SET KEY</p>
MAIN MENU	12:54P												
<b>FUNCTION</b>													
PROGRAM													
RESERVE													
GRAPH													
SETUP													
<table border="1"> <tr> <td>FUNCTION</td> <td>12:54P</td> </tr> <tr> <td><b>SUB SET</b></td> <td></td> </tr> <tr> <td>COMM SET</td> <td></td> </tr> <tr> <td>AT TUNING</td> <td></td> </tr> </table>	FUNCTION	12:54P	<b>SUB SET</b>		COMM SET		AT TUNING		<p>SUB SET setting                  MAIN MENU→ FUNCTION→ SUB SET→SET KEY                  SUB SET1, SUB SET2 (PAGE UP/DOWN KEY)</p>				
FUNCTION	12:54P												
<b>SUB SET</b>													
COMM SET													
AT TUNING													
<table border="1"> <tr> <td>SUB SET1</td> <td>12:54P</td> </tr> <tr> <td>OPER MODE: <b>PROG</b></td> <td></td> </tr> <tr> <td>PWR MODE : STOP</td> <td></td> </tr> <tr> <td>KEY LOCK : OFF</td> <td></td> </tr> <tr> <td>BUZZER : OFF</td> <td></td> </tr> <tr> <td>FUZZY : OFF</td> <td></td> </tr> </table>	SUB SET1	12:54P	OPER MODE: <b>PROG</b>		PWR MODE : STOP		KEY LOCK : OFF		BUZZER : OFF		FUZZY : OFF		<p>OPER MODE : FIX / PROG                  PWR MODE : State mode after power failure                  Can be recognized over 3 sec. power failure                  If power on within 3 sec. It is automatically running with HOT mode</p> <ul style="list-style-type: none"> <li>▶ STOP : After power failure, go to STOP state</li> <li>▶ COLD : After power failure, go to RUN on fix running or go to SEG1 on program running.</li> <li>▶ HOT : After power failure, running by previous data before power failure.</li> </ul> <p>KEY LOCK : Set key in possible / impossible</p> <ul style="list-style-type: none"> <li>▶ ON : Lock(Key in impossible)</li> <li>▶ OFF : Unlock(Key in possible)</li> </ul> <p>BUZZER : Set buzzer sound ON/OFF                  FUZZY : Set FUZZY ON/Off(Fuzzy : Overshoot suppressing function)</p>
SUB SET1	12:54P												
OPER MODE: <b>PROG</b>													
PWR MODE : STOP													
KEY LOCK : OFF													
BUZZER : OFF													
FUZZY : OFF													
<table border="1"> <tr> <td>SUB SET2</td> <td>12:54P</td> </tr> <tr> <td>FIX OP TM: <b>0</b> HR</td> <td></td> </tr> <tr> <td>                  0 MIN</td> <td></td> </tr> <tr> <td>FIX OP TM: OFF</td> <td></td> </tr> <tr> <td>TEMP SLOP: 0.0 %/M</td> <td></td> </tr> <tr> <td>HUMI SLOP: 0.0 %/M</td> <td></td> </tr> </table>	SUB SET2	12:54P	FIX OP TM: <b>0</b> HR		0 MIN		FIX OP TM: OFF		TEMP SLOP: 0.0 %/M		HUMI SLOP: 0.0 %/M		<p>FIX OP TM : Set FIX Operation time ON/OFF                  It is reserving function within 9999 hours and fix running is finishing after set the time.                  TEMP(HUMI) SLOP : Set the slop for TSP, it is increase/decrease to the target temp/humi gradually.</p>
SUB SET2	12:54P												
FIX OP TM: <b>0</b> HR													
0 MIN													
FIX OP TM: OFF													
TEMP SLOP: 0.0 %/M													
HUMI SLOP: 0.0 %/M													

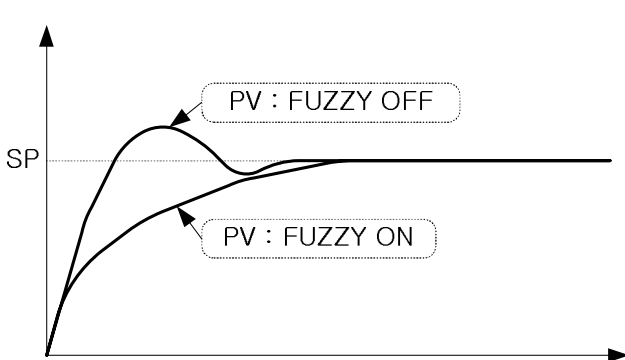

(Figure 1 : Overshoot suppressing function by FUZZY)

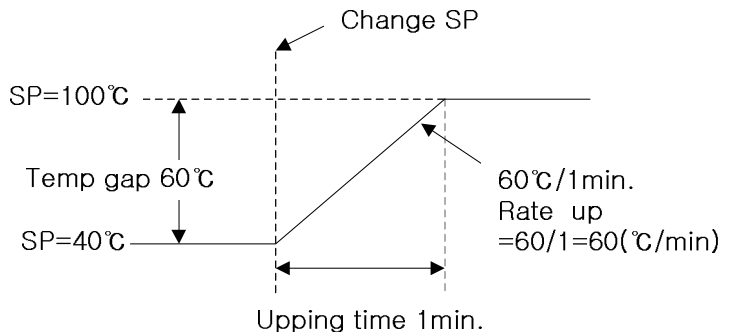

(Figure 2 : Ex. SLOPE setting)

<table border="1"> <tr> <td>FUNCTION</td> <td>12:54P</td> </tr> <tr> <td>SUB SET</td> <td></td> </tr> <tr> <td>COMM SET</td> <td></td> </tr> <tr> <td>AT TUNING</td> <td></td> </tr> </table>	FUNCTION	12:54P	SUB SET		COMM SET		AT TUNING		<p>Communication set                  MAIN MENU → FUNCTION → COMM SET → SET KEY</p>				
FUNCTION	12:54P												
SUB SET													
COMM SET													
AT TUNING													
<table border="1"> <tr> <td>COMM SET</td> <td>12:54P</td> </tr> <tr> <td>PROT.: <b>RS485</b></td> <td></td> </tr> <tr> <td>BPS : 9600</td> <td></td> </tr> <tr> <td>PRTY.: NONE</td> <td></td> </tr> <tr> <td>S.BIT: 1 D.LEN: 8</td> <td></td> </tr> <tr> <td>ADDR.: 1 RP.TM: 0</td> <td></td> </tr> </table>	COMM SET	12:54P	PROT.: <b>RS485</b>		BPS : 9600		PRTY.: NONE		S.BIT: 1 D.LEN: 8		ADDR.: 1 RP.TM: 0		<p>PROT : Protocol                  BPS : Speed (Bit per sec)                  PRTY : Parity                  S.BIT : Stop bit                  D.LEN : Data length                  ADDR : Address                  RP.TM : Response time</p>
COMM SET	12:54P												
PROT.: <b>RS485</b>													
BPS : 9600													
PRTY.: NONE													
S.BIT: 1 D.LEN: 8													
ADDR.: 1 RP.TM: 0													
<table border="1"> <tr> <td>FUNCTION</td> <td>12:54P</td> </tr> <tr> <td>SUB SET</td> <td></td> </tr> <tr> <td>COMM SET</td> <td></td> </tr> <tr> <td>AT TUNING</td> <td></td> </tr> </table>	FUNCTION	12:54P	SUB SET		COMM SET		AT TUNING		<p>AT TUNING set                  MAIN MENU → FUNCTION → AT TUNING → SET KEY                  AT TUNING is available on "FIX RUN" state only</p>				
FUNCTION	12:54P												
SUB SET													
COMM SET													
AT TUNING													
<table border="1"> <tr> <td>AUTO TUNNING</td> <td>12:54P</td> </tr> <tr> <td>TEMP.AT : <b>OFF</b></td> <td></td> </tr> <tr> <td>HUMI.AT : OFF</td> <td></td> </tr> </table>	AUTO TUNNING	12:54P	TEMP.AT : <b>OFF</b>		HUMI.AT : OFF		<p>Available on FIX RUN MODE only                  AUTO TUNING with SP on FIX MODE only then after auto tuning the value of tuning is saved on the correspond PID number</p>						
AUTO TUNNING	12:54P												
TEMP.AT : <b>OFF</b>													
HUMI.AT : OFF													

Symbol	Parameter	Range	Display	Unit	Default	Edit
OPER MODE	OPERATION MODE	PROG, FIX	Always	ABS	PROG	○
PWR MODE	POWER MODE	STOP, COLD, HOT	Always	ABS	STOP	○
KEY LOCK	KEY LOCK	OFF, ON	Always	ABS	OFF	○
BUZZER	BUZZER	OFF, ON	Always	ABS	ON	○
FUZZY	FUZZY	OFF, ON	Always	ABS	OFF	○
FIX OP TM.HR	FIX OP TIME(HOUR)	0 ~ 9999	Always	ABS	0	○
FIX OP TM.MIN	FIX OP TIME(MIN)	0~ 59	Always	ABS	0	○
FIX OP TM	FIX OP TIME	OFF, ON	Always	ABS	OFF	○
TEMP SLOP	TEMP SLOPE	T.EUS(0.0~100.0%) /MIN	Always	T.EUS /MIN	T.EUS(0.0%) /MINUTE	○
HUMI SLOP	HUMI SLOPE	H.EUS(0.0~100.0%) /MIN	Always	H.EUS /MIN	H.EUS(0.0%) /MINUTE	○
PROT	PROTOCOL	PCL0 (PC LINK), PCL1 (PC with SUM)	Always	ABS	PCL0	○
BPS	BAUD RATE	600, 1200, 2400, 4800, 9600	Always	ABS	9600	○
PRTY	PARITY	NONE, EVEN, ODD	Always	ABS	NONE	○
S.BIT	STOP BIT	1, 2	Always	ABS	1	○
D.LEN	DATA LENGTH	7, 8	Always	ABS	8	○
ADDR	ADDRESS	1 ~ 99 (Max. 31unit)	Always	ABS	1	○
RP.TM	RESPONSE TIME	0 ~ 10	Always	ABS	0	○
TEMP.AT	TEMP AUTO TUNING	OFF, ON	On FIX MODE	ABS	OFF	○
HUMI.AT	HUMI AUTO TUNING	OFF, ON	On FIX MODE	ABS	OFF	○

4.3.2 PROGRAM

<table border="1"> <tr> <td>MAIN MENU</td> <td>12:54P</td> </tr> <tr> <td colspan="2">FUNCTION</td> </tr> <tr> <td colspan="2"><b>PROGRAM</b></td> </tr> <tr> <td colspan="2">RESERVE</td> </tr> <tr> <td colspan="2">GRAPH</td> </tr> <tr> <td colspan="2">SETUP</td> </tr> </table>	MAIN MENU	12:54P	FUNCTION		<b>PROGRAM</b>		RESERVE		GRAPH		SETUP		<p>MENU KEY → MAIN → PROGRAM → SET KEY</p>																		
MAIN MENU	12:54P																														
FUNCTION																															
<b>PROGRAM</b>																															
RESERVE																															
GRAPH																															
SETUP																															
<table border="1"> <tr> <td>PROGRAM</td> <td>12:54P</td> </tr> <tr> <td colspan="2"><b>EDIT SEG</b></td> </tr> <tr> <td colspan="2">EDIT PT</td> </tr> <tr> <td colspan="2">TIME SG</td> </tr> <tr> <td colspan="2">WAIT SET</td> </tr> <tr> <td colspan="2">ALL DEL</td> </tr> </table>	PROGRAM	12:54P	<b>EDIT SEG</b>		EDIT PT		TIME SG		WAIT SET		ALL DEL		<p>EDIT SEG set MAIN MENU → PROGRAM → EDIT SEG → SET KEY</p>																		
PROGRAM	12:54P																														
<b>EDIT SEG</b>																															
EDIT PT																															
TIME SG																															
WAIT SET																															
ALL DEL																															
<table border="1"> <tr> <td>SG</td> <td>TEMP</td> <td>HUMI</td> <td>HH.MM</td> <td>123</td> </tr> <tr> <td>01</td> <td>-50.00</td> <td>0.0</td> <td>-0.01</td> <td>000</td> </tr> <tr> <td>02</td> <td>-50.00</td> <td>0.0</td> <td>-0.01</td> <td>000</td> </tr> <tr> <td>03</td> <td>-50.00</td> <td>0.0</td> <td>-0.01</td> <td>000</td> </tr> <tr> <td>04</td> <td>-50.00</td> <td>0.0</td> <td>-0.01</td> <td>000</td> </tr> <tr> <td>05</td> <td>-50.00</td> <td>0.0</td> <td>-0.01</td> <td>000</td> </tr> </table>	SG	TEMP	HUMI	HH.MM	123	01	-50.00	0.0	-0.01	000	02	-50.00	0.0	-0.01	000	03	-50.00	0.0	-0.01	000	04	-50.00	0.0	-0.01	000	05	-50.00	0.0	-0.01	000	<p>Set the temperature, humidity, time, TS1, TS2 and TS3 for each segment 1 : TS1(Time Signal1) 2 : TS2(Time Signal2) 3 : TS3(Time Signal3)</p>
SG	TEMP	HUMI	HH.MM	123																											
01	-50.00	0.0	-0.01	000																											
02	-50.00	0.0	-0.01	000																											
03	-50.00	0.0	-0.01	000																											
04	-50.00	0.0	-0.01	000																											
05	-50.00	0.0	-0.01	000																											
<table border="1"> <tr> <td>PROGRAM</td> <td>12:54P</td> </tr> <tr> <td colspan="2"><b>EDIT SEG</b></td> </tr> <tr> <td colspan="2"><b>EDIT PT</b></td> </tr> <tr> <td colspan="2">TIME SG</td> </tr> <tr> <td colspan="2">WAIT SET</td> </tr> <tr> <td colspan="2">ALL DEL</td> </tr> </table>	PROGRAM	12:54P	<b>EDIT SEG</b>		<b>EDIT PT</b>		TIME SG		WAIT SET		ALL DEL		<p>EDIT PT set MAIN MENU → PROGRAM → EDIT PTN → SET KEY</p>																		
PROGRAM	12:54P																														
<b>EDIT SEG</b>																															
<b>EDIT PT</b>																															
TIME SG																															
WAIT SET																															
ALL DEL																															
<table border="1"> <tr> <td>PT</td> <td>TOP</td> <td>END</td> <td>RPT</td> <td>JP</td> </tr> <tr> <td>01</td> <td>0</td> <td>0</td> <td>1</td> <td>0</td> </tr> <tr> <td>02</td> <td>0</td> <td>0</td> <td>1</td> <td>0</td> </tr> <tr> <td>03</td> <td>0</td> <td>0</td> <td>1</td> <td>0</td> </tr> <tr> <td>04</td> <td>0</td> <td>0</td> <td>1</td> <td>0</td> </tr> <tr> <td>05</td> <td>0</td> <td>0</td> <td>1</td> <td>0</td> </tr> </table>	PT	TOP	END	RPT	JP	01	0	0	1	0	02	0	0	1	0	03	0	0	1	0	04	0	0	1	0	05	0	0	1	0	<p>Set the segment of the top/end, repeat (number of time) and jump pattern number(wished link pattern number)</p>
PT	TOP	END	RPT	JP																											
01	0	0	1	0																											
02	0	0	1	0																											
03	0	0	1	0																											
04	0	0	1	0																											
05	0	0	1	0																											
<table border="1"> <tr> <td>PROGRAM</td> <td>12:54P</td> </tr> <tr> <td colspan="2"><b>EDIT SEG</b></td> </tr> <tr> <td colspan="2"><b>EDIT PT</b></td> </tr> <tr> <td colspan="2"><b>TIME SG</b></td> </tr> <tr> <td colspan="2">WAIT SET</td> </tr> <tr> <td colspan="2">ALL DEL</td> </tr> </table>	PROGRAM	12:54P	<b>EDIT SEG</b>		<b>EDIT PT</b>		<b>TIME SG</b>		WAIT SET		ALL DEL		<p>EDIT TIME SG set MAIN MENU → PROGRAM → TIME SG → SET KEY</p>																		
PROGRAM	12:54P																														
<b>EDIT SEG</b>																															
<b>EDIT PT</b>																															
<b>TIME SG</b>																															
WAIT SET																															
ALL DEL																															
<table border="1"> <tr> <td>NO</td> <td>ON.TM</td> <td>OFF.TM</td> </tr> <tr> <td>0</td> <td>TS OFF</td> <td>TS OFF</td> </tr> <tr> <td>1</td> <td>TS ON</td> <td>TS ON</td> </tr> <tr> <td>2</td> <td>00.00</td> <td>00.00</td> </tr> <tr> <td>3</td> <td>00.00</td> <td>00.00</td> </tr> <tr> <td>4</td> <td>00.00</td> <td>00.00</td> </tr> </table>	NO	ON.TM	OFF.TM	0	TS OFF	TS OFF	1	TS ON	TS ON	2	00.00	00.00	3	00.00	00.00	4	00.00	00.00	<p>NO 0, 1 : These are only for ON or OFF function NO 2~9 : These are only for time for ON/OFF In the view, ON/OFF is selected for Time Signal For define output by these setting, go and setting on MAIN MENU→ PROGRAM→ EDIT SEG → SET KEY</p>												
NO	ON.TM	OFF.TM																													
0	TS OFF	TS OFF																													
1	TS ON	TS ON																													
2	00.00	00.00																													
3	00.00	00.00																													
4	00.00	00.00																													



<table style="width: 100%; border-collapse: collapse;"> <tr> <td style="border: 1px solid black; padding: 2px;">PROGRAM</td> <td style="border: 1px solid black; padding: 2px;">12:54P</td> </tr> <tr> <td colspan="2" style="padding: 5px;">                     EDIT SEG                      EDIT PT  <b>WAIT SET</b>                      ALL DEL                 </td> </tr> </table>	PROGRAM	12:54P	EDIT SEG EDIT PT <b>WAIT SET</b> ALL DEL		WAIT SET set MAIN MENU → PROGRAM → WAIT SET → SET KEY
PROGRAM	12:54P				
EDIT SEG EDIT PT <b>WAIT SET</b> ALL DEL					
<table style="width: 100%; border-collapse: collapse;"> <tr> <td style="border: 1px solid black; padding: 2px;">WAIT SET</td> <td style="border: 1px solid black; padding: 2px;">12:54P</td> </tr> <tr> <td colspan="2" style="padding: 5px;">                     TEMP ZONE: <b>0.0</b> °C                      HUMI ZONE: <b>0.0</b> %                      WAIT TIME: <b>00.00</b> H.M                      WAIT USE : <b>OFF</b> </td> </tr> </table>	WAIT SET	12:54P	TEMP ZONE: <b>0.0</b> °C HUMI ZONE: <b>0.0</b> % WAIT TIME: <b>00.00</b> H.M WAIT USE : <b>OFF</b>		TEMP ZONE : The range of temperature for waiting zone HUMI ZONE : The range of humidity for waiting zone WAIT TIME : Time for wait WAIT USE : Use / Not use
WAIT SET	12:54P				
TEMP ZONE: <b>0.0</b> °C HUMI ZONE: <b>0.0</b> % WAIT TIME: <b>00.00</b> H.M WAIT USE : <b>OFF</b>					
<table style="width: 100%; border-collapse: collapse;"> <tr> <td style="border: 1px solid black; padding: 2px;">PROGRAM</td> <td style="border: 1px solid black; padding: 2px;">12:54P</td> </tr> <tr> <td colspan="2" style="padding: 5px;">                     EDIT SEG                      EDIT PT                      WAIT SET  <b>ALL DEL</b> </td> </tr> </table>	PROGRAM	12:54P	EDIT SEG EDIT PT WAIT SET <b>ALL DEL</b>		Clear all of the patterns & segments MAIN MENU → PROGRAM → ALL DEL → SET KEY
PROGRAM	12:54P				
EDIT SEG EDIT PT WAIT SET <b>ALL DEL</b>					
<table style="width: 100%; border-collapse: collapse;"> <tr> <td style="border: 1px solid black; padding: 2px;">ALL DELETE</td> <td style="border: 1px solid black; padding: 2px;">12:54P</td> </tr> <tr> <td colspan="2" style="padding: 5px;">                     PT A.CLR: <b>OFF</b>                      SEG A.CLR: <b>OFF</b> </td> </tr> </table>	ALL DELETE	12:54P	PT A.CLR: <b>OFF</b> SEG A.CLR: <b>OFF</b>		PT A.CLR : Clear all of the patterns SEG A.CLR : Clear all of the segments
ALL DELETE	12:54P				
PT A.CLR: <b>OFF</b> SEG A.CLR: <b>OFF</b>					

Symbol	Parameter	Range	Display	Unit	Default	Edit
SG	SEGMENT NUMBER	01 ~ 100(01,02,...,99,00)	Always	ABS	01	X
TEMP	TEMP SP	T.EU(0.0 ~ 100.0%)	Always	T.EU	T.EU (0.0%)	O
HUMI	HUMI SP	H.EU(0.0 ~ 100.0%)	Always	H.EU	H.EU (0.0%)	O
HH.MM	HOUR.MINUTE	-00.01(OFF) ~ 99.59	Always	ABS	-00.01(OFF)	O
1	TIME SIGNAL1	0(OFF) ~ 9	Always	ABS	0(OFF)	O
2	TIME SIGNAL2	0(OFF) ~ 9	Always	ABS	0(OFF)	O
3	TIME SIGNAL3	0(OFF) ~ 9	Always	ABS	0(OFF)	O
PT	PATTERN NUMBER	01 ~ 10	Always	ABS	01	X
TOP	START SEGMENT	1 ~ 100	Always	ABS	0	O
END	END SEGMENT	TOP ≤ END	Always	ABS	0	O
RPT	REPEAT SEGMENT	0(0=∞) ~ 999	Always	ABS	1	O
JP	JUMP PATTERN	0 ~ 10	Always	ABS	0	O
TEMP ZONE	TEMP WAIT ZONE	T.EUS(0.0 ~ 100.0%)	Always	T.EUS	T.EUS (0.0%)	O
HUMI ZONE	HUMI WAIT ZONE	H.EUS(0.0 ~ 100.0%)	Always	H.EUS	H.EUS (0.0%)	O

Symbol	Parameter	Range	Display	Unit	Default	Edit
WAIT TIME	WAIT TIME(HH.MM)	0.00 ~ 99.59	Always	ABS	0.00	○
WAIT USE	WAIT USE	ON, OFF	Always	ABS	OFF	○
PT A.CLR	ALL PATTERNS DELETE	OFF, ON	Always	ABS	OFF	○
SEG A.CLR	ALL SEGMENTS DELETE	OFF, ON	Always	ABS	OFF	○

※ Wait

The wait function holds off the transition of segment until deviation is cleared up. The use of this function is enabled by defining a wait zone that is a deviation range to determine the follow-up of PV data input, and a wait time, which is a period of waiting time until PV data enters the wait zone. When PV input enters the wait zone within the wait time, the operation shifts to the next.

If not, the shift takes place as soon as the wait time is over, The WTM should be set for prevent to infinite waiting

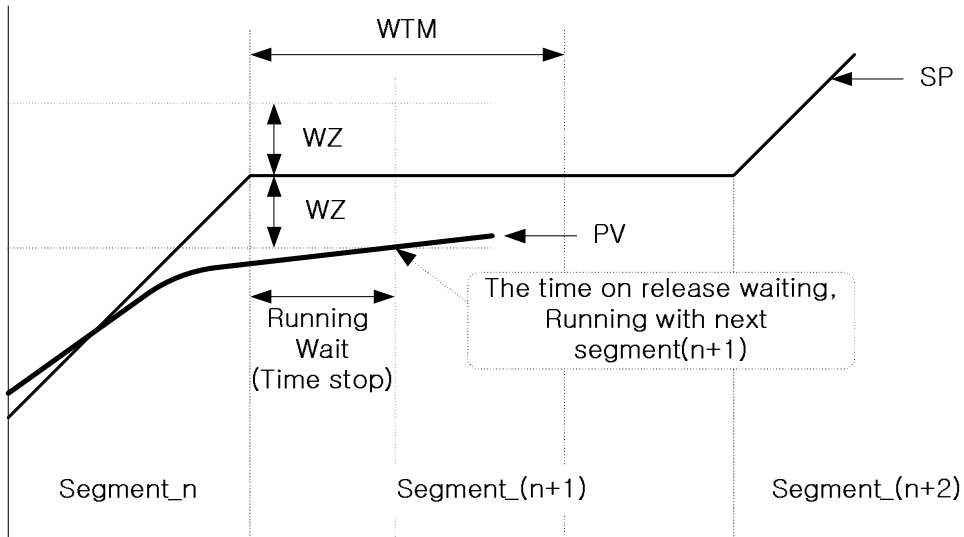

(Figure 3 : WAIT – Ex. Wait Function Release Within WTM)

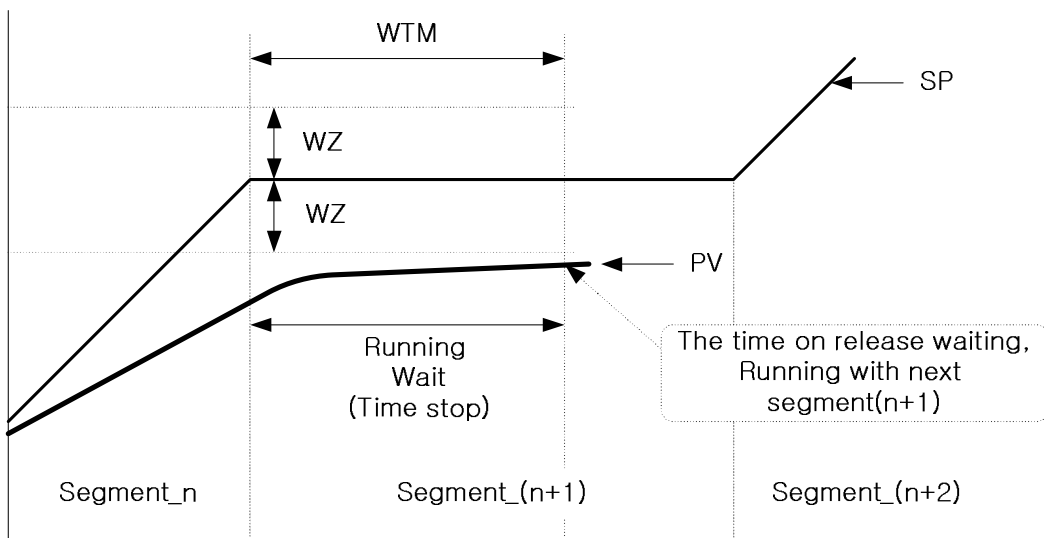

(Figure 4 : WAIT – Ex. PV can't enter the wait zone within WTM)

4.3.3 RESERVE

<table border="1" style="width: 100%; border-collapse: collapse;"> <tr> <td style="width: 50%; padding: 2px;">MAIN MENU</td> <td style="width: 50%; padding: 2px;">12:54P</td> </tr> <tr> <td colspan="2" style="padding: 2px;">                 FUNCTION                  PROGRAM  <b>RESERVE</b>                  GRAPH                  SETUP             </td> </tr> </table>	MAIN MENU	12:54P	FUNCTION PROGRAM <b>RESERVE</b> GRAPH SETUP		RESERVE set MENU KEY → MAIN → RESERVE → SET KEY
MAIN MENU	12:54P				
FUNCTION PROGRAM <b>RESERVE</b> GRAPH SETUP					

<table border="1" style="width: 100%; border-collapse: collapse;"> <tr> <td style="padding: 2px;"><b>NOW: 3Y10M22D12H40M</b></td> </tr> <tr> <td style="padding: 2px;">RUN DATE :</td> </tr> <tr> <td style="padding: 2px;">1Y 1M 1D 1H 0M</td> </tr> <tr> <td style="padding: 2px;">SET DATE :</td> </tr> <tr> <td style="padding: 2px;">3Y 10M 22D 12H 40M</td> </tr> <tr> <td style="padding: 2px;">RESERVE : OFF</td> </tr> </table>	<b>NOW: 3Y10M22D12H40M</b>	RUN DATE :	1Y 1M 1D 1H 0M	SET DATE :	3Y 10M 22D 12H 40M	RESERVE : OFF	NOW : Display present year, month, date and time which is set on SET DATE area RUN DATE : Set reserved starting year, month, date and time SET DATE : Set present year, month, date and time RESERVE : Use/not use
<b>NOW: 3Y10M22D12H40M</b>							
RUN DATE :							
1Y 1M 1D 1H 0M							
SET DATE :							
3Y 10M 22D 12H 40M							
RESERVE : OFF							

Symbol	Parameter	Range	Display	Unit	Default	Edit
Y	YEAR	0 ~ 99	Always	ABS	1	○ (Except Now date)
M	MONTH	1 ~ 12	Always	ABS	1	
D	DAY	1 ~ 31	Always	ABS	1	
H	HOUR	0 ~ 23	Always	ABS	1	
M	MINUTE	0 ~ 59	Always	ABS	1	
RESERVE	RESERVE SET	OFF, ON	Always	ABS	OFF	X

4.3.4 GRAPH

<div style="border: 1px solid black; padding: 2px;"> <p style="text-align: right; margin: 0;">MAIN MENU    12:54P</p> <p style="text-align: center; margin: 5px 0;">FUNCTION PROGRAM RESERVE <b>GRAPH</b> SETUP</p> </div>	<p>GRAPH set MENU KEY → MAIN → GRAPH → SET KEY</p>
--	--

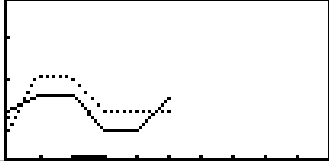
<div style="border: 1px solid black; padding: 2px;"> <p style="text-align: right; margin: 0;">GRAPH VIEW    12:54P</p> <div style="display: flex; align-items: flex-start; padding: 5px;"> <div style="margin-right: 10px;"> <p>PTN 2</p> <p>SEG 5</p> </div>  </div> </div>	<p>Display segment on pattern by graph for temperature &amp; humidity PTN : Set the pattern No. for wished see SEG : Set the segment No. for display starting</p>
---	---

Symbol	Parameter	Range	Display	Unit	Default	Edit
PTN	PATTERN NUMBER	1 ~ 10	Always	ABS	Set PT on MAIN	O
SEG	SEGMENT NUMBER	1 ~ 99	Always	ABS	Set SEG on PT	X
T.SP	TEMP SP	T.EU(0.0 ~ 100.0%)	Always	T.EU	X	X
H.SP	HUMI SP	H.EU(0.0 ~ 100.0%)	HUMI OPER = ON	H.EU	X	X

## 4.4 SETUP

### 4.4.1 INPUT

<table border="1"> <tr> <td>MAIN MENU</td> <td>12:54P</td> </tr> <tr> <td>FUNCTION</td> <td></td> </tr> <tr> <td>PROGRAM</td> <td></td> </tr> <tr> <td>RESERVE</td> <td></td> </tr> <tr> <td>GRAPH</td> <td></td> </tr> <tr> <td><b>SETUP</b></td> <td></td> </tr> </table>	MAIN MENU	12:54P	FUNCTION		PROGRAM		RESERVE		GRAPH		<b>SETUP</b>		<p>SETUP set. MENU KEY → MAIN → SETUP → SET KEY</p>
MAIN MENU	12:54P												
FUNCTION													
PROGRAM													
RESERVE													
GRAPH													
<b>SETUP</b>													
<table border="1"> <tr> <td>SETUP PASS</td> <td>12:54P</td> </tr> <tr> <td>PASS: <b>0</b></td> <td></td> </tr> </table>	SETUP PASS	12:54P	PASS: <b>0</b>		<p>SET KEY → Illuminate No. → Password with UP, DOWN, SHIFT KEY → SET KEY</p>								
SETUP PASS	12:54P												
PASS: <b>0</b>													
<table border="1"> <tr> <td>SETUP MENU</td> <td>12:54P</td> </tr> <tr> <td><b>INPUT</b></td> <td>DO CONFIG</td> </tr> <tr> <td>OUTPUT</td> <td>BIAS SET</td> </tr> <tr> <td>ON/OFF</td> <td>DI NAME</td> </tr> <tr> <td>INNER</td> <td>PASSWORD</td> </tr> <tr> <td>ALARM</td> <td>PID SET</td> </tr> </table>	SETUP MENU	12:54P	<b>INPUT</b>	DO CONFIG	OUTPUT	BIAS SET	ON/OFF	DI NAME	INNER	PASSWORD	ALARM	PID SET	<p>INPUT → SET KEY</p>
SETUP MENU	12:54P												
<b>INPUT</b>	DO CONFIG												
OUTPUT	BIAS SET												
ON/OFF	DI NAME												
INNER	PASSWORD												
ALARM	PID SET												
<table border="1"> <tr> <td>TEMP INFUT</td> <td>12:54P</td> </tr> <tr> <td>TYPE :</td> <td><b>PT-1</b></td> </tr> <tr> <td>RNG. HIGH:</td> <td>150.0 °C</td> </tr> <tr> <td>RNG. LOW :</td> <td>-50.0 °C</td> </tr> </table>	TEMP INFUT	12:54P	TYPE :	<b>PT-1</b>	RNG. HIGH:	150.0 °C	RNG. LOW :	-50.0 °C	<p>TYPE : Set sensor type for temperature (PT-1, PT-2 or DCV) Resolution of PT-1 is higher than PT-2's RNG.HIGH/LOW : Rang of using temperature ▶ PT-1 : -50.00~150.00°C ▶ PT-2 : -100.0~200°C ▶ DCV : 1~5V</p>				
TEMP INFUT	12:54P												
TYPE :	<b>PT-1</b>												
RNG. HIGH:	150.0 °C												
RNG. LOW :	-50.0 °C												
<table border="1"> <tr> <td>TEMP INFUT</td> <td>12:54P</td> </tr> <tr> <td>TYPE :</td> <td><b>DCV</b></td> </tr> <tr> <td>RNG. HIGH:</td> <td>5.000 U</td> </tr> <tr> <td>RNG. LOW :</td> <td>1.000 U</td> </tr> <tr> <td>SCL. HIGH:</td> <td>200.0 °C</td> </tr> <tr> <td>SCL. LOW :</td> <td>-100.0 °C</td> </tr> </table>	TEMP INFUT	12:54P	TYPE :	<b>DCV</b>	RNG. HIGH:	5.000 U	RNG. LOW :	1.000 U	SCL. HIGH:	200.0 °C	SCL. LOW :	-100.0 °C	<p>It is shown, sensor type is DCV for temperature SCL.HIGH(LOW) : Set the input range scale when input type is DCV SCALE : -100.0 ~ 200.0°C</p>
TEMP INFUT	12:54P												
TYPE :	<b>DCV</b>												
RNG. HIGH:	5.000 U												
RNG. LOW :	1.000 U												
SCL. HIGH:	200.0 °C												
SCL. LOW :	-100.0 °C												
<table border="1"> <tr> <td>HUMI INFUT</td> <td>12:54P</td> </tr> <tr> <td>TYPE :</td> <td><b>PT</b></td> </tr> <tr> <td>RNG. HIGH:</td> <td>110.0 %</td> </tr> <tr> <td>RNG. LOW :</td> <td>-10.0 %</td> </tr> </table>	HUMI INFUT	12:54P	TYPE :	<b>PT</b>	RNG. HIGH:	110.0 %	RNG. LOW :	-10.0 %	<p>TYPE : Set sensor type for humidity (PT or DCV) RNG.HIGH(LOW) : Rang of using Humidity ▶ PT : -10.0~110.0% ▶ DCV : 1~5V</p>				
HUMI INFUT	12:54P												
TYPE :	<b>PT</b>												
RNG. HIGH:	110.0 %												
RNG. LOW :	-10.0 %												
<table border="1"> <tr> <td>HUMI INFUT</td> <td>12:54P</td> </tr> <tr> <td>TYPE :</td> <td><b>DCV</b></td> </tr> <tr> <td>RNG. HIGH:</td> <td>5.000 U</td> </tr> <tr> <td>RNG. LOW :</td> <td>1.000 U</td> </tr> <tr> <td>SCL. HIGH:</td> <td>100.0 %</td> </tr> <tr> <td>SCL. LOW :</td> <td>0.0 %</td> </tr> </table>	HUMI INFUT	12:54P	TYPE :	<b>DCV</b>	RNG. HIGH:	5.000 U	RNG. LOW :	1.000 U	SCL. HIGH:	100.0 %	SCL. LOW :	0.0 %	<p>It is shown, sensor type is DCV for humidity SCL.HIGH(LOW) : Set the input range scale when input type is DCV SCALE : 0.0 ~ 100.0%</p>
HUMI INFUT	12:54P												
TYPE :	<b>DCV</b>												
RNG. HIGH:	5.000 U												
RNG. LOW :	1.000 U												
SCL. HIGH:	100.0 %												
SCL. LOW :	0.0 %												

<table style="width: 100%; border-collapse: collapse;"> <tr> <td style="border: 1px solid black; padding: 2px;">INPUT BS/FT</td> <td style="border: 1px solid black; padding: 2px;">12:54P</td> </tr> <tr> <td style="border: 1px solid black; padding: 2px;">T. BIAS : <span style="background-color: black; color: white; padding: 0 5px;">0.0</span> °C</td> <td style="border: 1px solid black; padding: 2px;"></td> </tr> <tr> <td style="border: 1px solid black; padding: 2px;">T. FL : 0 SEC</td> <td style="border: 1px solid black; padding: 2px;"></td> </tr> <tr> <td style="border: 1px solid black; padding: 2px;">H. BIAS : 0.0 %</td> <td style="border: 1px solid black; padding: 2px;"></td> </tr> <tr> <td style="border: 1px solid black; padding: 2px;">S. FL : 0 SEC</td> <td style="border: 1px solid black; padding: 2px;"></td> </tr> </table>	INPUT BS/FT	12:54P	T. BIAS : <span style="background-color: black; color: white; padding: 0 5px;">0.0</span> °C		T. FL : 0 SEC		H. BIAS : 0.0 %		S. FL : 0 SEC		<p>T.BIAS : Set bias for temperature                  H.BIAS : Set bias for humidity high-frequency                  T.FL : Set for protect any effect from high frequency to temperature input                  H.FL : Set for protect any effect from high frequency to humidity input</p>		
INPUT BS/FT	12:54P												
T. BIAS : <span style="background-color: black; color: white; padding: 0 5px;">0.0</span> °C													
T. FL : 0 SEC													
H. BIAS : 0.0 %													
S. FL : 0 SEC													
<table style="width: 100%; border-collapse: collapse;"> <tr> <td style="border: 1px solid black; padding: 2px;">INPUT ADJUST</td> <td style="border: 1px solid black; padding: 2px;">12:54P</td> </tr> <tr> <td style="border: 1px solid black; padding: 2px;">DRY TEMP : 0.0 °C</td> <td style="border: 1px solid black; padding: 2px;"></td> </tr> <tr> <td style="border: 1px solid black; padding: 2px;">WET TEMP : 0.0 °C</td> <td style="border: 1px solid black; padding: 2px;"></td> </tr> <tr> <td style="border: 1px solid black; padding: 2px;">HUMIDITY : 0.0 %</td> <td style="border: 1px solid black; padding: 2px;"></td> </tr> <tr> <td style="border: 1px solid black; padding: 2px;">WET ADJUST : <span style="background-color: black; color: white; padding: 0 5px;">0.0</span> °C</td> <td style="border: 1px solid black; padding: 2px;"></td> </tr> <tr> <td style="border: 1px solid black; padding: 2px;">ADJUST : NONE</td> <td style="border: 1px solid black; padding: 2px;"></td> </tr> </table>	INPUT ADJUST	12:54P	DRY TEMP : 0.0 °C		WET TEMP : 0.0 °C		HUMIDITY : 0.0 %		WET ADJUST : <span style="background-color: black; color: white; padding: 0 5px;">0.0</span> °C		ADJUST : NONE		<p>DRY TEMP : Temp of dry probe.                  WET TEMP : Temp of wet probe.                  HUMIDITY : Relative humidity.                  WET ADJUST : Adjust temp of wet part.                  ADJUST : Using when the temp of dry/wet part are RTD TYPE                  Temp of dry part and wet part are being same temp as select this button.</p>
INPUT ADJUST	12:54P												
DRY TEMP : 0.0 °C													
WET TEMP : 0.0 °C													
HUMIDITY : 0.0 %													
WET ADJUST : <span style="background-color: black; color: white; padding: 0 5px;">0.0</span> °C													
ADJUST : NONE													

Symbol	Parameter	Range	Display	Unit	Default	Edit
TYPE	TEMP SENSOR	PT_1(-50.00~150.00) PT_2(-100.0~200.0) DCV(1.000~5.000)	Always	ABS	PT_1	○
	HUMI SENSOR	PT(-10.0~110.0) DCV(1.000~5.000)			PT	
RNG.HIGH	TEMP RANGE HIGH HUMI RANGE HIGH	T.EU(0.0~100.0%) RNG.LOW<RNG.HIGH	Always	T.EU H.EU	T.EU(100.0%) H.EU(100.0%)	○
RNG.LOW	TEMP RANGE LOW HUMI RANGE LOW	H.EU(0.0~100.0%) RNG.LOW<RNG.HIGH	Always	T.EU H.EU	T.EU(0.0%) H.EU(0.0%)	○
SCL.HIGH	TEMP SCALE HIGH HUMI SCALE HIGH	-100.0 ~ 200.0°C SCL.LOW<SCL.HIGH	TYPE = DCV	ABS	200.0°C 100.0%	○
SCL.LOW	TEMP SCALE LOW HUMI SCALE LOW	0.0 ~ 100.0% SCL.LOW<SCL.HIGH	TYPE = DCV	ABS	-100.0°C 0.0%	○
T.BIAS	TEMP BIAS	T.EUS(-100 ~ 100%)	Always	T.EUS	T.EUS(0.0%)	○
T.FL	TEMP FILTER	0 ~ 120s	Always	ABS	0 SEC	○
H.BIAS	HUMI BIAS	H.EUS(-20 ~ 20%)	Always	H.EUS	H.EUS(0.0%)	○
H.FL	HUMI FILTER	0 ~ 120s	Always	ABS	0 SEC	○
DRY TEMP	DRY TEMP	T.EU(-5.0 ~ 105.0%)	Always	T.EU	X	X
WET TEMP	WET TEMP	W.EU(0.0 ~ 100.0%)	Always	W.EU	X	X
HUMIDITY	HUMIDITY	H.EU(0.0 ~ 100.0%)	Always	H.EU	X	X
WET ADJUST	WET ADJUST	H.EUS (-100.0 ~ 100.0%)	Always	H.EUS	H.EUS(0.0%)	○
ADJUST	ADJUST	NONE, EXE, CLR	Always	ABS	NONE	○

4.4.2 OUTPUT

<table border="1" style="width: 100%; border-collapse: collapse;"> <tr> <td style="text-align: left;">SETUP MENU</td> <td style="text-align: right;">12:54P</td> </tr> <tr> <td>INPUT</td> <td>DO CONFIG</td> </tr> <tr> <td><b>OUTPUT</b></td> <td>BIAS SET</td> </tr> <tr> <td>ON/OFF</td> <td>DI NAME</td> </tr> <tr> <td>INNER</td> <td>PASSWORD</td> </tr> <tr> <td>ALARM</td> <td>PID SET</td> </tr> </table>	SETUP MENU	12:54P	INPUT	DO CONFIG	<b>OUTPUT</b>	BIAS SET	ON/OFF	DI NAME	INNER	PASSWORD	ALARM	PID SET	OUTPUT → SET KEY
SETUP MENU	12:54P												
INPUT	DO CONFIG												
<b>OUTPUT</b>	BIAS SET												
ON/OFF	DI NAME												
INNER	PASSWORD												
ALARM	PID SET												

<table border="1" style="width: 100%; border-collapse: collapse;"> <tr> <td style="text-align: left;">TEMP OUTPUT</td> <td style="text-align: right;">12:54P</td> </tr> <tr> <td>TYPE</td> <td>: SSR</td> </tr> <tr> <td>DIRECT</td> <td>: <b>REUR.</b></td> </tr> <tr> <td>CYCLE</td> <td>: 1 S</td> </tr> <tr> <td>ARW</td> <td>: 0.0 %</td> </tr> <tr> <td>AT. GAIN</td> <td>: 1.0 %</td> </tr> </table>	TEMP OUTPUT	12:54P	TYPE	: SSR	DIRECT	: <b>REUR.</b>	CYCLE	: 1 S	ARW	: 0.0 %	AT. GAIN	: 1.0 %	TYPE : Output type for control temperature (SSR) DIRECT : Set reverse/forward for PID control CYCLE : Set output cycle ARW : The parameter to set deviation width to prevent overshoot. When the control output reaches High-Limited value, for preventing Overshoot by integral action, It is stopping ordinary action for integrals and shift for ARW(Anti-Reset Wind-Up). AT GAIN : The parameter to set proportional PID control by obtaining AUTO TUNING. Reduce AT-G, Cycle time became rapid. Increase AT-G, control status became more stable. Smaller value, will become more hunting.
TEMP OUTPUT	12:54P												
TYPE	: SSR												
DIRECT	: <b>REUR.</b>												
CYCLE	: 1 S												
ARW	: 0.0 %												
AT. GAIN	: 1.0 %												

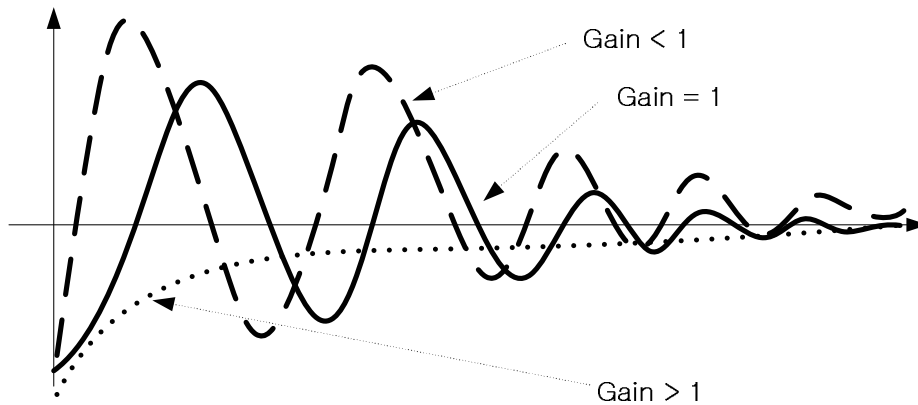

(Figure 5 : AT GAIN)

<table border="1" style="width: 100%; border-collapse: collapse;"> <tr> <td style="text-align: left;">HUMI OUTPUT</td> <td style="text-align: right;">12:54P</td> </tr> <tr> <td>TYPE</td> <td>: SSR</td> </tr> <tr> <td>DIRECT</td> <td>: <b>REUR.</b></td> </tr> <tr> <td>CYCLE</td> <td>: 1 S</td> </tr> <tr> <td>ARW</td> <td>: 0.0 %</td> </tr> <tr> <td>AT. GAIN</td> <td>: 1.0 %</td> </tr> </table>	HUMI OUTPUT	12:54P	TYPE	: SSR	DIRECT	: <b>REUR.</b>	CYCLE	: 1 S	ARW	: 0.0 %	AT. GAIN	: 1.0 %	TYPE : Output type for control temperature (SSR) DIRECT : Set reverse/forward for PID control CYCLE : Set output cycle ARW : The parameter to set deviation width to prevent overshoot. When the control output reaches High-Limited value, for preventing Overshoot by integral action, It is stopping ordinary action for integrals and shift for ARW(Anti-Reset Wind-Up). AT GAIN : The parameter to set proportional PID control by obtaining AUTO TUNING. Reduce AT-G, Cycle time became rapid. Increase AT-G, control status became more stable. Smaller value, will become more hunting.
HUMI OUTPUT	12:54P												
TYPE	: SSR												
DIRECT	: <b>REUR.</b>												
CYCLE	: 1 S												
ARW	: 0.0 %												
AT. GAIN	: 1.0 %												

<table border="1" style="width: 100%; border-collapse: collapse;"> <tr> <td style="text-align: left;">TEMP RET.</td> <td style="text-align: right;">12:54P</td> </tr> <tr> <td>KIND</td> <td>: <b>P U</b></td> </tr> <tr> <td>RNG. HIGH:</td> <td>150.0 °C</td> </tr> <tr> <td>RNG. LOW :</td> <td>-50.0 °C</td> </tr> </table>	TEMP RET.	12:54P	KIND	: <b>P U</b>	RNG. HIGH:	150.0 °C	RNG. LOW :	-50.0 °C	KIND : Set type of temperature retransmission (PV, SP, MV) RNG.HIGH : Range of high RNG.LOW : Range of low PV : PV SP : SP MV : MV
TEMP RET.	12:54P								
KIND	: <b>P U</b>								
RNG. HIGH:	150.0 °C								
RNG. LOW :	-50.0 °C								

<b>HUMI RET.</b>	<b>12:54P</b>	KIND : Set type of humidity retransmission (PV, SP, MV) RNG.HIGH : Range of high RNG.LOW : Range of low PV : PV SP : SP MV : MV
KIND : <b>PV</b>	RNG. HIGH: <b>100.0 %</b>	
RNG. LOW : <b>0.0 %</b>		

Symbol	Parameter	Range	Display	Unit	Default	Edit
DIRECT	TEMP DIRECT HUMI DIRECT	REVERSE, FORWARD	Always	ABS	REVERSE	○
CYCLE	TEMP CYCLE HUMI CYCLE	1 ~ 300	Always	ABS	1	○
ARW	ANTI RESET Wind-Up Select	0.0 ~ 200.0%	Always	ABS	100.0%	○
AT GAIN	AT GAIN	0.1 ~ 10.0	Always	ABS	1.0	○
KIND	RETRANSMISSION	PV, SP, MV	Always	ABS	PV	○
RNG.HIGH	TEMP RANGE HIGH HUMI RANGE HIGH	T.EU(0.0 ~ 100.0%) RNG.LOW<RNG.HIGH	PV, SP	T.EU H.EU	T.EU(100.0%) H.EU(100.0%)	○
RNG.LOW	TEMP RANGE LOW HUMI RANGE LOW	H.EU(0.0 ~ 100.0%) RNG.LOW<RNG.HIGH	PV, SP	T.EU H.EU	T.EU(0.0%) H.EU(0.0%)	○



4.4.3 ON/OFF

<pre> SETUP MENU 12:54P INPUT      DO CONFIG OUTPUT     BIAS SET ON/OFF     DI NAME INNER      PASSWORD ALARM      PID SET             </pre>	<p>ON/OFF → SET KEY</p>
<pre> ON/OFF T1 12:54P HIGH.SP : -50.0 °C MIDDLE.SP: -50.0 °C LOW.SP : -50.0 °C HIGH.DIFF: 0.0 °C LOW.DIFF : 0.0 °C             </pre>	<p>ON/OFF mode for temperature  HIGH.SP : Set low SP on ON/OFF  HIGH.DIFF : Deviation value for high zone</p>
<pre> ON/OFF T2 12:54P HIGH.SP : -50.0 °C MIDDLE.SP: -50.0 °C LOW.SP : -50.0 °C HIGH.DIFF: 0.0 °C LOW.DIFF : 0.0 °C             </pre>	<p>ON/OFF mode for temperature  MIDDLE.SP : Set middle SP on ON/OFF</p>
<pre> ON/OFF T3 12:54P HIGH.SP : -50.0 °C MIDDLE.SP: -50.0 °C LOW.SP : -50.0 °C HIGH.DIFF: 0.0 °C LOW.DIFF : 0.0 °C             </pre>	<p>ON/OFF mode for temperature  LOW.SP : Set low SP on ON/OFF  LOW.DIFF : Deviation value for low zone</p>
<pre> ON/OFF H1 12:54P HIGH.SP : 0.0 % MIDDLE.SP: 0.0 % LOW.SP : 0.0 % HIGH.DIFF: 0.0 % LOW.DIFF : 0.0 %             </pre>	<p>ON/OFF mode for humidity  HIGH.SP : Set high SP on ON/OFF  LOW.DIFF : Deviation value for high zone</p>



HIGH.SP must be set before MIDDLE.SP or LOW.SP

Symbol	Parameter	Range	Display	Unit	Default	Edit
LOW.SP	LOW SP	T.EU(0.0~100.0%) H.EU(0.0~100.0%)	Always	T.EU H.EU	T.EU(0.0%) H.EU(0.0%)	○
MIDDLE.SP	MIDDLE SP	RL≤LOW.SP	Always	T.EU H.EU	T.EU(0.0%) H.EU(0.0%)	○
HIGH.SP	HIGH SP	<MIDDLE.SP <HIGH.SP≤RH	Always	T.EU H.EU	T.EU(0.0%) H.EU(0.0%)	○
HIGH.DIFF	HIGH DIFFERENCE	T.EUS(0.0 ~ 10.0%) H.EUS(0.0 ~ 10.0%)	Always	T.EUS H.EUS	T.EUS(0.0%) H.EUS(0.0%)	○
LOW.DIFF	LOW DIFFERENCE	T.EUS(0.0 ~ 10.0%) H.EUS(0.0 ~ 10.0%)	Always	T.EUS H.EUS	T.EUS(0.0%) H.EUS(0.0%)	○

1. T1~T3, H1 (ON after set time, the set time adapted on first "ON" state at running)

- ①  $NPV < LSP(LOW.SP) \rightarrow Output : OFF$
- ②  $NPV > HSP(HIGH.SP) \rightarrow Output : OFF$
- ③  $LSP \leq NPV < MSP(MIDDLE.SP)$   
 $NPV \geq NSP-LD(LOW.DIFF) \rightarrow Output : ON$   
 $NPV < NSP-LD \rightarrow Output : OFF$
- ④  $MSP < NPV < HSP,$   
 $NPV < NSP + HD(HIGH.DIFF) \rightarrow Output : OFF$   
 $NPV \geq NSP + HD \rightarrow Output : ON$

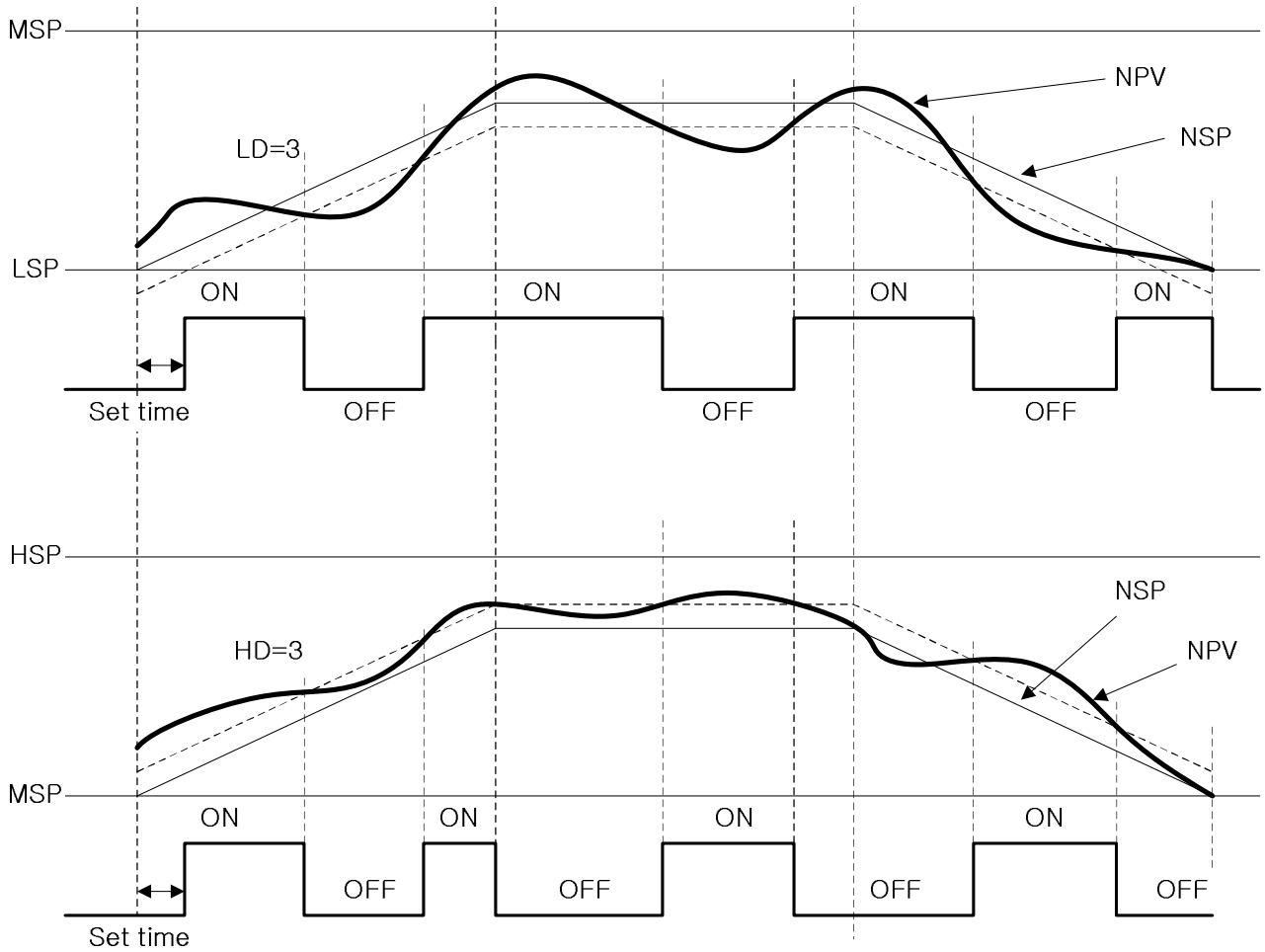

(Figure 6 : ON/OFF MODE)

2. T4 output

T4 is turning on after set delay time after T3 turned on  
 T4 is turning off together when T3 turn off

4.4.4 Inner Signal(IS)

<table border="1" style="width: 100%; border-collapse: collapse;"> <tr> <td style="text-align: left;">SETUP MENU</td> <td style="text-align: right;">12:54P</td> </tr> <tr> <td>INPUT</td> <td>DO CONFIG</td> </tr> <tr> <td>OUTPUT</td> <td>BIAS SET</td> </tr> <tr> <td>ON/OFF</td> <td>DI NAME</td> </tr> <tr> <td><b>INNER</b></td> <td>PASSWORD</td> </tr> <tr> <td>ALARM</td> <td>PID SET</td> </tr> </table>	SETUP MENU	12:54P	INPUT	DO CONFIG	OUTPUT	BIAS SET	ON/OFF	DI NAME	<b>INNER</b>	PASSWORD	ALARM	PID SET	INNER → SET KEY
SETUP MENU	12:54P												
INPUT	DO CONFIG												
OUTPUT	BIAS SET												
ON/OFF	DI NAME												
<b>INNER</b>	PASSWORD												
ALARM	PID SET												
<table border="1" style="width: 100%; border-collapse: collapse;"> <tr> <td style="text-align: left;">INNER SIGNAL1</td> <td style="text-align: right;">12:54P</td> </tr> <tr> <td>KIND</td> <td>: T.SP °C</td> </tr> <tr> <td>RNG. HIGH</td> <td>: -50.0 °C</td> </tr> <tr> <td>RNG. LOW</td> <td>: -50.0 °C</td> </tr> <tr> <td>BAND</td> <td>: IN.B</td> </tr> <tr> <td>DELAY.TM</td> <td>: 00.00 M.S</td> </tr> </table>	INNER SIGNAL1	12:54P	KIND	: T.SP °C	RNG. HIGH	: -50.0 °C	RNG. LOW	: -50.0 °C	BAND	: IN.B	DELAY.TM	: 00.00 M.S	KIND : Set type of humidity retransmission (PV, SP, MV) RNG.HIGH(LOW) : Range for IS BAND : Direct of IS band (IN.B/OUT.B) DELAY.TM : IS delay time IS1 connected with 1ST REF, 2ND REF output INNER SIGNAL : There are 1 ~ 6 pages of IS
INNER SIGNAL1	12:54P												
KIND	: T.SP °C												
RNG. HIGH	: -50.0 °C												
RNG. LOW	: -50.0 °C												
BAND	: IN.B												
DELAY.TM	: 00.00 M.S												

Symbol	Parameter	Range	Display	Unit	Default	Edit
KIND	INNER SIGNAL KIND	T.TSP, T.PV, T.SP H.TSP, H.PV, H.SP	Always	ABS	T.SP	○
RNG.HIGH	IS RANGE HIGH	T.EU(0.0~100.0%) H.EU(0.0~100.0%)	Always	T.EU H.EU	EU(0.0%)	○
RNG.LOW	IS RANGE LOW	RNG.LOW<RNG.HIGH	Always	T.EU H.EU	EU(0.0%)	○
BAND	BAND DIRECT	IN.B, OUT.B	Always	ABS	IN.B	○
DELAY.TM	DELAY TIME	00.00~99.59 MM.SS	Always	ABS	00.00	○

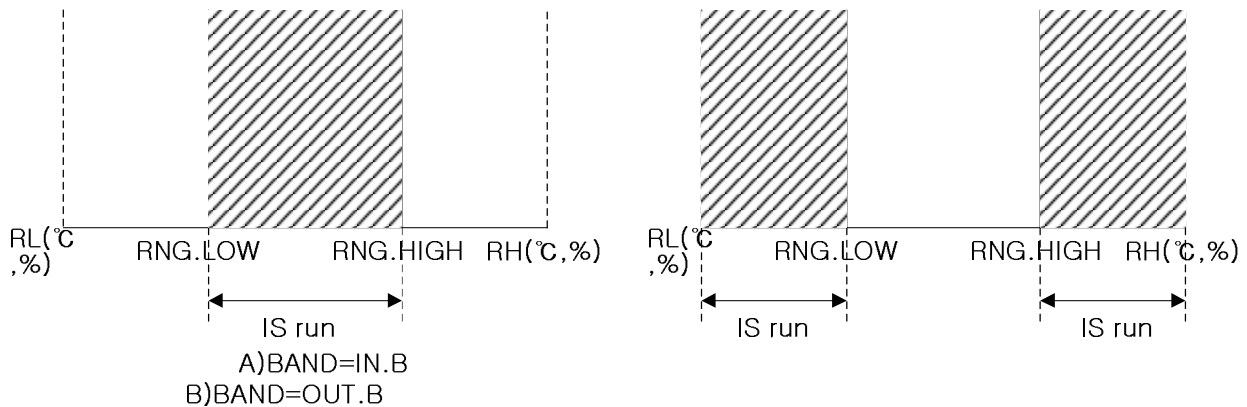

(Figure 7 : Ex. Inner Signal Zone)

4.4.5 ALARM

<pre> SETUP MENU 12:54P INPUT      DO CONFIG OUTPUT     BIAS SET ON/OFF     DI NAME INNER      PASSWORD <b>ALARM</b>     PID SET                 </pre>	ALARM → SET KEY
<pre> ALARM SIGNAL1 12:54P ITEM          : <b>TEMP</b> KIND          : AH.F POINT         : 150.0 °C HYS.          : 1.0 °C DELAY.TM      : 00.00 M.S                 </pre>	ITEM : Set item of alarm KIND : Set type of alarm POINT : Set alarm point HYS. : Set hysteresis for alarm DELAY.TM : Set the delay time for alarm output ALARM SIGNAL : There are 1 ~ 4 pages of alarm



Alarm is working on even STOP state

Symbol	Parameter	Range	Display	Unit	Default	Edit
ITEM	ALARM ITEM	TEMP, HUMI	Display	ABS	TEMP	O
KIND	ALARM KIND	AH.F, AL.F, DH.F, DL.F DH.R, DL.R, DO.F, DI.F AH.R, AL.R, AH.FS AL.FS, DH, FS, DL.FS DH.RS, DL.RS, DO.FS DI.FS, AH.RS, AL.RS	Display	ABS	ALARM 1, 3 → AH.F ALARM 2, 4 → AL.F	O
POINT	ALARM POINT	T.EU(-100.0~100.0%) H.EU(-100.0~100.0%)	Display	T.EU H.EU	EU(100.0%)	O
HYS.	ALARM HYSTERESIS	T.EUS(0.0~100.0%) H.EUS(0.0~100.0%)	Display	T.EUS H.EUS	EUS(0.5%)	O
DELAY.TM	DELAY TIME	00.00~99.59 M.S	Display	ABS	00.00	O

(Table 1 : Alarm Type)

No.	Alarm Type	Output Direct		Standby		Display Data
		For	Rev	On	Off	
1	PV Upper-Limit	O		O		AH.F
2	PV Lower-Limit	O		O		AL.F
3	Deviation Upper-Limit	O		O		DH.F
4	Deviation Lower-Limit	O		O		DL.F
5	Deviation Upper-Limit		O	O		DH.R
6	Deviation Lower-Limit		O	O		DL.R
7	Deviation Upper & Lower-Limit	O		O		DO.F
8	Deviation Upper & Lower-Limit Range	O		O		DI.F
9	PV Upper-Limit		O	O		AH.R
10	PV Lower-Limit		O	O		AL.R
11	PV Upper-Limit	O			O	AH.FS
12	PV Lower-Limit	O			O	AL.FS
13	Deviation Upper-Limit	O			O	DH.FS
14	Deviation Lower-Limit	O			O	DL.FS
15	Deviation Upper-Limit		O		O	DH.RS
16	Deviation Lower-Limit		O		O	DL.RS
17	Deviation Upper & Lower-Limit	O			O	DO.FS
18	Deviation Upper & Lower-Limit Range	O			O	DI.FS
19	PV Upper-Limit		O		O	AH.RS
20	PV Lower-Limit		O		O	AL.RS

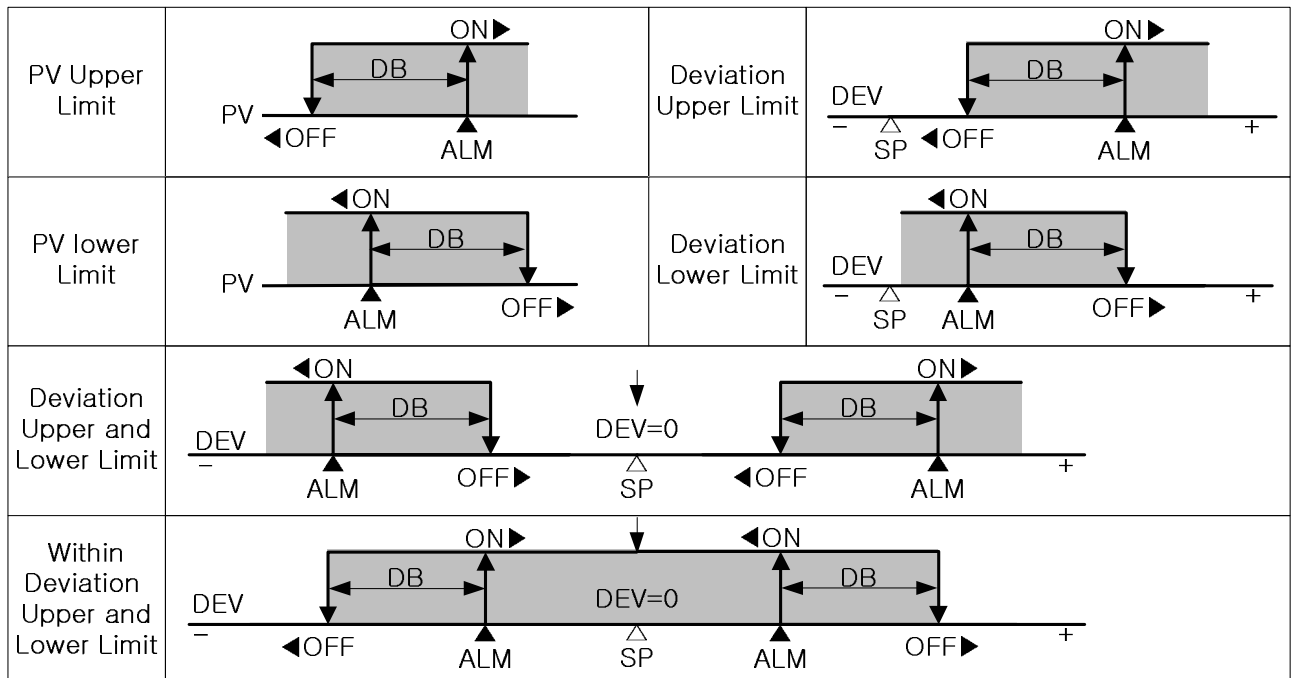

(Fig 8 : Alarm Operation)

4.4.6 DO CONFIG

<table border="1"> <tr> <td>SETUP MENU</td> <td>12:54P</td> </tr> <tr> <td>INPUT</td> <td>DO CONFIG</td> </tr> <tr> <td>OUTPUT</td> <td>BIAS SET</td> </tr> <tr> <td>ON/OFF</td> <td>DI NAME</td> </tr> <tr> <td>INNER</td> <td>PASSWORD</td> </tr> <tr> <td>ALARM</td> <td>PID SET</td> </tr> </table>	SETUP MENU	12:54P	INPUT	DO CONFIG	OUTPUT	BIAS SET	ON/OFF	DI NAME	INNER	PASSWORD	ALARM	PID SET	<p>DO CONFIG → SET KEY</p>
SETUP MENU	12:54P												
INPUT	DO CONFIG												
OUTPUT	BIAS SET												
ON/OFF	DI NAME												
INNER	PASSWORD												
ALARM	PID SET												
<table border="1"> <tr> <td>DO CONFIG1</td> <td>12:54P</td> </tr> <tr> <td>IS1 : 0</td> <td>IS6 : 0</td> </tr> <tr> <td>IS2 : 0</td> <td>TS1 : 0</td> </tr> <tr> <td>IS3 : 0</td> <td>TS2 : 0</td> </tr> <tr> <td>IS4 : 0</td> <td>TS3 : 0</td> </tr> <tr> <td>IS5 : 0</td> <td></td> </tr> </table>	DO CONFIG1	12:54P	IS1 : 0	IS6 : 0	IS2 : 0	TS1 : 0	IS3 : 0	TS2 : 0	IS4 : 0	TS3 : 0	IS5 : 0		<p>DO CONFIG set (1st page) Set the relay number (1~12) for IS1~6 and TS1~3</p>
DO CONFIG1	12:54P												
IS1 : 0	IS6 : 0												
IS2 : 0	TS1 : 0												
IS3 : 0	TS2 : 0												
IS4 : 0	TS3 : 0												
IS5 : 0													
<table border="1"> <tr> <td>DO CONFIG2</td> <td>12:54P</td> </tr> <tr> <td>AL1 : 0</td> <td>T.RUN: 0</td> </tr> <tr> <td>AL2 : 0</td> <td>H.RUN: 0</td> </tr> <tr> <td>AL3 : 0</td> <td></td> </tr> <tr> <td>AL4 : 0</td> <td></td> </tr> </table>	DO CONFIG2	12:54P	AL1 : 0	T.RUN: 0	AL2 : 0	H.RUN: 0	AL3 : 0		AL4 : 0		<p>DO CONFIG set (2nd page) Set the relay number (1~12) for ALARM1~4, T.RUN and H.RUN</p>		
DO CONFIG2	12:54P												
AL1 : 0	T.RUN: 0												
AL2 : 0	H.RUN: 0												
AL3 : 0													
AL4 : 0													
<table border="1"> <tr> <td>DO CONFIG3</td> <td>12:54P</td> </tr> <tr> <td>T1 : 0</td> <td>00.00 M.S</td> </tr> <tr> <td>T2 : 0</td> <td>00.00 M.S</td> </tr> <tr> <td>T3 : 0</td> <td>00.00 M.S</td> </tr> <tr> <td>T4 : 0</td> <td>00.00 M.S</td> </tr> <tr> <td>H1 : 0</td> <td>00.00 M.S</td> </tr> </table>	DO CONFIG3	12:54P	T1 : 0	00.00 M.S	T2 : 0	00.00 M.S	T3 : 0	00.00 M.S	T4 : 0	00.00 M.S	H1 : 0	00.00 M.S	<p>DO CONFIG set (3rd page) Set the relay number (1~12) for T1~T4, and H1.RUN also set the delay time for each items The delay time effect only first ON time and next ON is not effect from delay time T1, T2, T3, H1 : Working after delay time T4 : Working after delay time, after T3 ON</p>
DO CONFIG3	12:54P												
T1 : 0	00.00 M.S												
T2 : 0	00.00 M.S												
T3 : 0	00.00 M.S												
T4 : 0	00.00 M.S												
H1 : 0	00.00 M.S												
<table border="1"> <tr> <td>DO CONFIG4</td> <td>12:54P</td> </tr> <tr> <td>T.UP : 0</td> <td>0.0 °C</td> </tr> <tr> <td>T.SOK : 0</td> <td>0 MIN</td> </tr> <tr> <td>T.DN : 0</td> <td>0.0 °C</td> </tr> </table>	DO CONFIG4	12:54P	T.UP : 0	0.0 °C	T.SOK : 0	0 MIN	T.DN : 0	0.0 °C	<p>DO CONFIG set (3rd page) Set the relay number (1~12) for T.UP, T.SOK, and T.DN T.UP : Output until X°C [X=T.SP - set temperature] T.SOK : Output until X min [X=SOAK zone time - set time] T.DN : Output until X°C [X=T.SP - set temperature]</p>				
DO CONFIG4	12:54P												
T.UP : 0	0.0 °C												
T.SOK : 0	0 MIN												
T.DN : 0	0.0 °C												

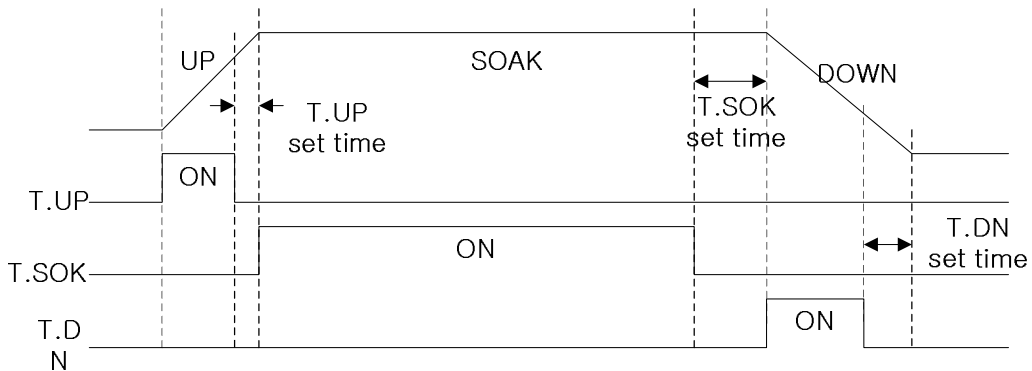

(Figure 9 : Ex. UP, SOAK, DOWN)

<b>DO CONFIG5</b>	<b>12:54P</b>
H.UP : <input checked="" type="checkbox"/>	0.0%
H.SOK : <input type="checkbox"/>	0MIN
H.DN : <input type="checkbox"/>	0.0%

DO CONFIG set (5th page)  
 Set the relay number (1~12) for H.UP, H.SOK, and H.DN  
 H.UP : Output until X% [X=TSP - set humidity]  
 H.SOK : Output until X min [X=SOAK zone time - set time]  
 H.DN : Output until X% [X=T.SP - set humidity]

<b>DO CONFIG6</b>	<b>12:54P</b>
DRAIN : <input checked="" type="checkbox"/>	0MIN
ERROR : <input type="checkbox"/>	0MIN
PTEND : <input type="checkbox"/>	0SEC
1_REF : <input type="checkbox"/>	0SEC
2_REF : <input type="checkbox"/>	0MIN

DO CONFIG set (6th page)  
 DRAIN : Output on the zone that humidity is not used.  
 ERROR : Output in set time when DI2~DI4 is occur.  
 PTEND : Output in set time when program finish.  
 1\_REF, 2\_REF : Output after set time when IS1 is working.  
 It is useful for Refrigerator 1, 2.

Symbol	Parameter	Range	Display	Unit	Default	Edit
IS1	INNER SIGNAL1	0~120(0:OUTPUT OFF)	Always	ABS	0	O
IS2	INNER SIGNAL2	0~120(0:OUTPUT OFF)	Always	ABS	0	O
IS3	INNER SIGNAL3	0~120(0:OUTPUT OFF)	Always	ABS	0	O
IS4	INNER SIGNAL4	0~120(0:OUTPUT OFF)	Always	ABS	0	O
IS5	INNER SIGNAL5	0~120(0:OUTPUT OFF)	Always	ABS	0	O
IS6	INNER SIGNAL6	0~120(0:OUTPUT OFF)	Always	ABS	0	O
TS1	TIME SIGNAL1	0~120(0:OUTPUT OFF)	Always	ABS	0	O
TS2	TIME SIGNAL2	0~120(0:OUTPUT OFF)	Always	ABS	0	O
TS3	TIME SIGNAL3	0~120(0:OUTPUT OFF)	Always	ABS	0	O
AL1	ALARM SIGNAL1	0~120(0:OUTPUT OFF)	Always	ABS	0	O
AL2	ALARM SIGNAL2	0~120(0:OUTPUT OFF)	Always	ABS	0	O
AL3	ALARM SIGNAL3	0~120(0:OUTPUT OFF)	Always	ABS	0	O
AL4	ALARM SIGNAL4	0~120(0:OUTPUT OFF)	Always	ABS	0	O
T.RUN	TEMP RUN	0~120(0:OUTPUT OFF)	Always	ABS	0	O
H.RUN	HUMI RUN	0~120(0:OUTPUT OFF)	Always	ABS	0	O
T1	T1 SIGNAL	0~120(0:OUTPUT OFF)	Always	ABS	0	O
T1 PARA	T1 SIGNAL PARA	0.00~99.59 MM.SS	Always	ABS	00.00	O
T2	T2 SIGNAL	0~120(0:OUTPUT OFF)	Always	ABS	0	O
T2 PARA	T2 SIGNAL PARA	0.00~99.59 MM.SS	Always	ABS	00.00	O
T3	T3 SIGNAL	0~120(0:OUTPUT OFF)	Always	ABS	0	O
T3 PARA	T3 SIGNAL PARA	0.00~99.59 MM.SS	Always	ABS	00.00	O
T4	T4 SIGNAL	0~120(0:OUTPUT OFF)	Always	ABS	0	O
T4 PARA	T4 SIGNAL PARA	0.00~99.59 MM.SS	Always	ABS	00.00	O
H1	H1 SIGNAL	0~120(0:OUTPUT OFF)	Always	ABS	0	O
H1 PARA	H1 SIGNAL PARA	0.00~99.59 MM.SS	Always	ABS	00.00	O

Symbol	Parameter	Range	Display	Unit	Default	Edit
T.UP	TEMP UP SIGNAL	0~120(0:OUTPUT OFF)	Always	ABS	0	○
T.UP PARA	TEMP UP PARA	T.EUS(0.0~100.0%)	Always	T.EUS	T.EUS (0.0%)	○
T.SOK	TEMP SOAK SIGNAL	0~120(0:OUTPUT OFF)	Always	ABS	0	○
T.SOK PARA	TEMP SOAK PARA	0~999 MIN	Always	ABS	0	○
T.DN	TEMP DOWN SIGNAL	0~120(0:OUTPUT OFF)	Always	ABS	0	○
T.DN PARA	TEMP DOWN PARA	T.EUS(0.0~100.0%)	Always	T.EUS	T.EUS (0.0%)	○
H.UP	HUMI UP SIGNAL	0~120(0:OUTPUT OFF)	Always	ABS	0	○
H.UP PARA	HUMI UP PARA	H.EUS(0.0~100.0%)	Always	H.EUS	H.EUS (0.0%)	○
H.SOK	HUMI SOAK SIGNAL	0~120(0:OUTPUT OFF)	Always	ABS	0	○
H.SOK PARA	HUMI SOAK PARA	0~999 MIN	Always	ABS	0	○
H.DN	HUMI DOWN SIGNAL	0~120(0:OUTPUT OFF)	Always	ABS	0	○
H.DN PARA	HUMI DOWN PARA	H.EUS(0.0~100.0%)	Always	H.EUS	H.EUS (0.0%)	○
DRAIN	DRAIN SIGNAL	0~120(0:OUTPUT OFF)	Always	ABS	0	○
DRAIN PARA	DRAIN PARA	0~999 MIN	Always	ABS	0	○
ERROR	ERROR SIGNAL	0~120(0:OUTPUT OFF)	Always	ABS	0	○
ERROR PARA	ERROR PARA	0~999 MIN	Always	ABS	0	○
PTEND	PTEND SIGNAL	0~120(0:OUTPUT OFF)	Always	ABS	0	○
PTEND PARA	PTEND PARA	0~999 SEC	Always	ABS	0	○
1_REF	FIRST REFERENCE SIGNAL	0~120(0:OUTPUT OFF)	Always	ABS	0	○
1_REF PARA	FIRST REF. PARA	0~999 SEC	Always	ABS	0	○
2_REF	SECOND REFERENCE SIGNAL	0~120(0:OUTPUT OFF)	Always	ABS	0	○
2_REF PARA	SECOND REF. PARA	0~999 MIN	Always	ABS	0	○



4.4.7 BIAS SET

<b>SETUP MENU</b> 12:54P	BIAS SET → SET KEY
INPUT DO CONFIG	
OUTPUT <b>BIAS SET</b>	
ON/OFF DI NAME	
INNER PASSWORD	
ALARM PID SET	

<b>D. TEMP BIAS</b> 12:54P	Set bias for dry temperature P : Point (Boundary point) D : Bias value
RL(P/D) <b>-50.0</b> 0.0	
P1(P/D) 150.0 0.0	
P2(P/D) 150.0 0.0	
RH(P/D) 150.0 0.0	
<b>DRY TEMP : 57.02°c</b>	

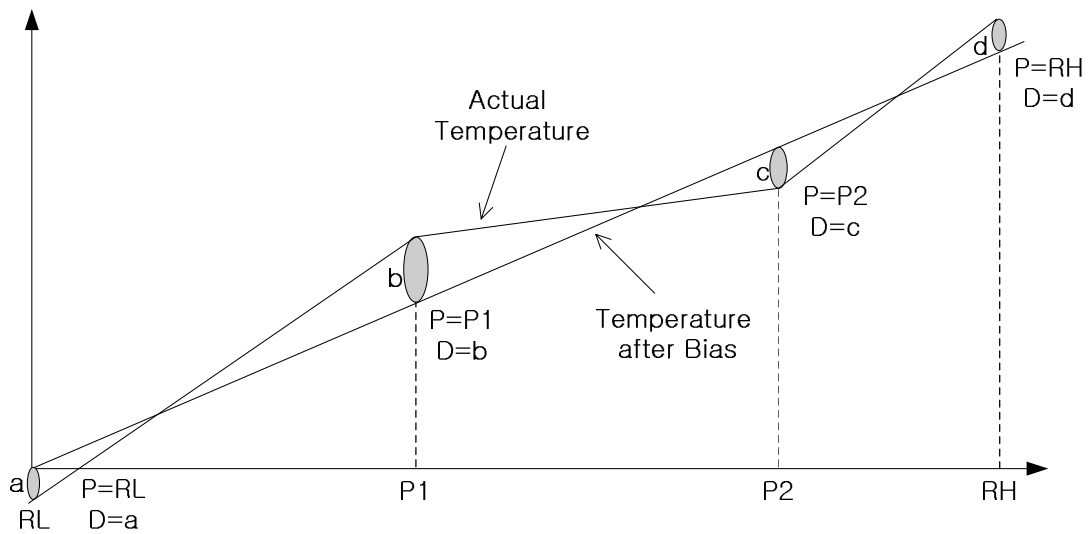

(Figure 10 : Ex. Piece Bias Formula)

<b>W. HUMI BIAS</b> 12:54P	Set bias for wet humidity P : Point (Boundary point) D : Bias value
RL(P/D) <b>-10.0</b> 0.0	
P1(P/D) 110.0 0.0	
P2(P/D) 110.0 0.0	
RH(P/D) 110.0 0.0	
<b>W: 27.02% RH: 100.0%</b>	

<b>R. HUMI BIAS</b> 12:54P	Set bias for relative humidity P : Point (Boundary point) D : Bias value
RL(P/D) <b>0.0</b> 0.0	
P1(P/D) 100.0 0.0	
P2(P/D) 100.0 0.0	
RH(P/D) 100.0 0.0	
<b>W: 27.02% RH: 100.0%</b>	

Symbol	Parameter	Range	Display	Unit	Default	Edit
DP.RL	TEMP REFERENCE BIAS RL	T.EU(0.0~100.0%) RL≤DP.RL<DP.P1 <DP.P2<DP.RH≤RH	Always	T.EU	T.EU(0.0%)	○
DP.P1	TEMP REFERENCE BIAS POINT1		Always	T.EU	T.EU(100.0%)	○
DP.P2	TEMP REFERENCE BIAS POINT2		Always	T.EU	T.EU(100.0%)	○
DP.PH	TEMP REFERENCE BIAS RH		Always	T.EU	T.EU(100.0%)	○
DD.RL	TEMP BIAS VALUE OF RL	T.EUS(-10.0~10.0%)	Always	T.EUS	T.EUS(0.0%)	○
DD.P1	TEMP BIAS VAUE OF POINT1		Always	T.EUS	T.EUS(0.0%)	○
DD.P2	TEMP BIAS VALUE OF POINT2		Always	T.EUS	T.EUS(0.0%)	○
DD.RH	TEMP BIAS VALUE OF RH		Always	T.EUS	T.EUS(0.0%)	○
DRY TEMP	DRY TEMP	T.EU(0.0~100.0%)	Always	T.EU	X	X
WP.RL	WET TEMP REF. BIAS RL	W.EU(0.0~100.0%) RL≤WP.RL<WP.P1 <WP.P2<WP.RH≤RH	Always	W.EU	W.EU(0.0%)	○
WP.P1	WET TEMP REF. BIAS POINT1		Always	W.EU	W.EU(100.0%)	○
WP.P2	WET TEMP REF. BIAS POINT2		Always	W.EU	W.EU(100.0%)	○
WP.RH	WET TEMP REF. BIAS RH		Always	W.EU	W.EU(100.0%)	○
WD.RL	WET TEMP BIAS VALUE OF RL	W.EUS(-10.0~10.0%)	Always	W.EUS	W.EUS(0.0%)	○
WD.P1	WET TEMP BIAS VAUE OF POINT1		Always	W.EUS	W.EUS(0.0%)	○
WD.P2	WET TEMP BIAS VAUE OF POINT2		Always	W.EUS	W.EUS(0.0%)	○
WD.RH	WET TEMP BIAS VALUE OF RH		Always	W.EUS	W.EUS(0.0%)	○
W	WET TEMP	W.EU(0.0~100.0%)	Always	W.EU	X	X
RP.RL	HUMIDITY REF. BIAS RL	H.EU(0.0~100.0%) RL≤RP.RL<RP.P1 <RP.P2<RP.RH≤RH	Always	H.EU	H.EU(0.0%)	○
RP.P1	HUMIDITY REF. BIAS POINT1		Always	H.EU	H.EU(100.0%)	○
RP.P2	HUMIDITY REF. BIAS POINT2		Always	H.EU	H.EU(100.0%)	○
RP.RH	HUMIDITY REF. BIAS RH		Always	H.EU	H.EU(100.0%)	○
RD.RL	HUMIDITY BIAS VALUE OF RL	H.EUS(-10.0~10.0%)	Always	H.EUS	H.EUS(0.0%)	○
RD.P1	HUMIDITY BIAS VAUE OF POINT1		Always	H.EUS	H.EUS(0.0%)	○
RD.P2	HUMIDITY BIAS VALUE OF POINT2		Always	H.EUS	H.EUS(0.0%)	○
RD.RH	HUMIDITY BIAS VALUE OF RH		Always	H.EUS	H.EUS(0.0%)	○
RH	HUMIDITY	H.EU(0.0~100.0%)	Always	H.EU	X	X

4.4.8 DI NAME

<table border="1" style="width: 100%; border-collapse: collapse;"> <tr> <td style="text-align: right;">SETUP MENU</td> <td style="text-align: left;">12:54P</td> </tr> <tr> <td>INPUT</td> <td>DO CONFIG</td> </tr> <tr> <td>OUTPUT</td> <td>BIAS SET</td> </tr> <tr> <td>ON/OFF</td> <td><b>DI NAME</b></td> </tr> <tr> <td>INNER</td> <td>PASSWORD</td> </tr> <tr> <td>ALARM</td> <td>PID SET</td> </tr> </table>	SETUP MENU	12:54P	INPUT	DO CONFIG	OUTPUT	BIAS SET	ON/OFF	<b>DI NAME</b>	INNER	PASSWORD	ALARM	PID SET	DI NAME → SET KEY
SETUP MENU	12:54P												
INPUT	DO CONFIG												
OUTPUT	BIAS SET												
ON/OFF	<b>DI NAME</b>												
INNER	PASSWORD												
ALARM	PID SET												
<table border="1" style="width: 100%; border-collapse: collapse;"> <tr> <td style="text-align: right;">DI NAME</td> <td style="text-align: left;">12:54P</td> </tr> <tr> <td>D1 NAME</td> <td>: RUN/STOP_</td> </tr> <tr> <td>D2 NAME</td> <td>: <b>ERROR_02_</b></td> </tr> <tr> <td>D3 NAME</td> <td>: ERROR_03_</td> </tr> <tr> <td>D4 NAME</td> <td>: ERROR_04_</td> </tr> <tr> <td>TOG GROUP</td> <td>: <b>ABCD_</b></td> </tr> </table>	DI NAME	12:54P	D1 NAME	: RUN/STOP_	D2 NAME	: <b>ERROR_02_</b>	D3 NAME	: ERROR_03_	D4 NAME	: ERROR_04_	TOG GROUP	: <b>ABCD_</b>	DI1 : RUN/STOP → Not changeable DI2, 3, 4 NAME : SET KEY → UP, DOWN key TOG GROUP : PAGE UP, PAGE DOWN key when name is illuminate
DI NAME	12:54P												
D1 NAME	: RUN/STOP_												
D2 NAME	: <b>ERROR_02_</b>												
D3 NAME	: ERROR_03_												
D4 NAME	: ERROR_04_												
TOG GROUP	: <b>ABCD_</b>												

Symbol	Parameter	Range	Display	Unit	Default	Edit
DI1 NAME	DI1 NAME	RUN/STOP	Always	ABS	RUN/STOP	X
DI2 NAME	DI2 NAME	0 ~ 9, A ~ Z, Symbols	Always	ABS	ERROR 02	O
DI3 NAME	DI3 NAME	0 ~ 9, A ~ Z, Symbols	Always	ABS	ERROR 03	O
DI4 NAME	DI4 NAME	0 ~ 9, A ~ Z, Symbols	Always	ABS	ERROR 04	O
TOG GROUP	TOG GROUP	0 ~ 9, A ~ Z, Symbols	Always	ABS	ABCD	X

4.4.9 PASSWORD

<table border="1" style="width: 100%; border-collapse: collapse;"> <tr> <td style="text-align: center;">SETUP MENU</td> <td style="text-align: right;">12:54P</td> </tr> <tr> <td>INPUT</td> <td>DO CONFIG</td> </tr> <tr> <td>OUTPUT</td> <td>BIAS SET</td> </tr> <tr> <td>ON/OFF</td> <td>DI NAME</td> </tr> <tr> <td>INNER</td> <td><b>PASSWORD</b></td> </tr> <tr> <td>ALARM</td> <td>PID SET</td> </tr> </table>	SETUP MENU	12:54P	INPUT	DO CONFIG	OUTPUT	BIAS SET	ON/OFF	DI NAME	INNER	<b>PASSWORD</b>	ALARM	PID SET	PASSWORD → SET KEY
SETUP MENU	12:54P												
INPUT	DO CONFIG												
OUTPUT	BIAS SET												
ON/OFF	DI NAME												
INNER	<b>PASSWORD</b>												
ALARM	PID SET												
<table border="1" style="width: 100%; border-collapse: collapse;"> <tr> <td style="text-align: center;">PASSWORD</td> <td style="text-align: right;">12:54P</td> </tr> <tr> <td style="font-size: 2em;">PASS: <span style="background-color: black; color: black;">          </span> 0</td> <td></td> </tr> <tr> <td>PROG OPER: ON</td> <td></td> </tr> <tr> <td>HUMI OPER: ON</td> <td></td> </tr> </table>	PASSWORD	12:54P	PASS: <span style="background-color: black; color: black;">          </span> 0		PROG OPER: ON		HUMI OPER: ON		Set the new password SET KEY → UP, DOWN, SHIFT key → SET KEY PROG OPER : ON → edit "OPER MODE" , OFF → not edit "OPER MODE" PROG OPER is not available on "RUN". HUMI OPER : ON → 2-LOOP (Temperature/Humidity) OFF → 1-LOOP (Temperature)				
PASSWORD	12:54P												
PASS: <span style="background-color: black; color: black;">          </span> 0													
PROG OPER: ON													
HUMI OPER: ON													



Default password is 0(ZERO)  
 After changing password, please confirm your new password  
 ► If you forget the password, connect Samwontech or our agency for reset service  
 All of the data that you set before will be changed to default after reset

Symbol	Parameter	Range	Display	Unit	Default	Edit
PASSWORD	PASSWORD SETTING	0 ~ 9999	Always	ABS	0	○
PROG OPER	PROG OPERATION MODE	ON,OFF	Always	ABS	ON	○
HUMI OPER	HUMIDITY OPERATION MODE	ON,OFF	Always	ABS	ON	○

4.4.10 PID SET

<table border="1" style="width: 100%; border-collapse: collapse;"> <tr> <td style="text-align: center;">SETUP MENU</td> <td style="text-align: right;">12:54P</td> </tr> <tr> <td>INPUT</td> <td>DO CONFIG</td> </tr> <tr> <td>OUTPUT</td> <td>BIAS SET</td> </tr> <tr> <td>ON/OFF</td> <td>DI NAME</td> </tr> <tr> <td>INNER</td> <td>PASSWORD</td> </tr> <tr> <td>ALARM</td> <td><b>PID SET</b></td> </tr> </table>	SETUP MENU	12:54P	INPUT	DO CONFIG	OUTPUT	BIAS SET	ON/OFF	DI NAME	INNER	PASSWORD	ALARM	<b>PID SET</b>	PID SET → SET KEY
SETUP MENU	12:54P												
INPUT	DO CONFIG												
OUTPUT	BIAS SET												
ON/OFF	DI NAME												
INNER	PASSWORD												
ALARM	<b>PID SET</b>												
<table border="1" style="width: 100%; border-collapse: collapse;"> <tr> <td style="text-align: center;">PID ZONE</td> <td style="text-align: right;">12:54P</td> </tr> <tr> <td>TEMP.RP1 :</td> <td>50.0 °C</td> </tr> <tr> <td>TEMP.RP2 :</td> <td>50.0 °C</td> </tr> <tr> <td>HUMI.RP :</td> <td>50.0 %</td> </tr> </table>	PID ZONE	12:54P	TEMP.RP1 :	50.0 °C	TEMP.RP2 :	50.0 °C	HUMI.RP :	50.0 %	TEMP.RP1, RP2 : Boundary value on temperature span for PID zone HUMI.RP : Boundary value on humidity span for PID zone				
PID ZONE	12:54P												
TEMP.RP1 :	50.0 °C												
TEMP.RP2 :	50.0 °C												
HUMI.RP :	50.0 %												

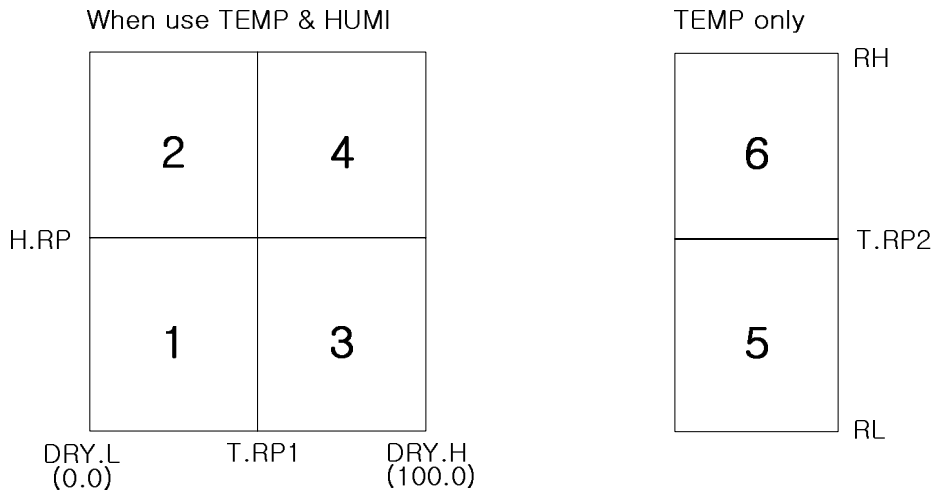

(Figure 11 : PID Group)

<table border="1" style="width: 100%; border-collapse: collapse;"> <tr> <td style="text-align: center;">PID 1</td> <td style="text-align: right;">12:54P</td> </tr> <tr> <td>T.P: 5.0%</td> <td>H.P: 5.0%</td> </tr> <tr> <td>T.I: 120S</td> <td>H.I: 120S</td> </tr> <tr> <td>T.D: 30S</td> <td>H.D: 30S</td> </tr> <tr> <td>TOH: 100.0%</td> <td>HOH: 100.0%</td> </tr> <tr> <td>TOL: 0.0%</td> <td>HOL: 0.0%</td> </tr> </table>	PID 1	12:54P	T.P: 5.0%	H.P: 5.0%	T.I: 120S	H.I: 120S	T.D: 30S	H.D: 30S	TOH: 100.0%	HOH: 100.0%	TOL: 0.0%	HOL: 0.0%	T.P/T.I/T.D/H.P/H.I/H.D : Temperature/Humidity P, I, D value for PID 1 T(H)OH, T(H)OL : High/low value for temperature/humidity for MV
PID 1	12:54P												
T.P: 5.0%	H.P: 5.0%												
T.I: 120S	H.I: 120S												
T.D: 30S	H.D: 30S												
TOH: 100.0%	HOH: 100.0%												
TOL: 0.0%	HOL: 0.0%												
⋮	⋮												
<table border="1" style="width: 100%; border-collapse: collapse;"> <tr> <td style="text-align: center;">PID 6</td> <td style="text-align: right;">12:54P</td> </tr> <tr> <td>T.P: 5.0%</td> <td></td> </tr> <tr> <td>T.I: 120S</td> <td></td> </tr> <tr> <td>T.D: 30S</td> <td></td> </tr> <tr> <td>TOH: 100.0%</td> <td></td> </tr> <tr> <td>TOL: 0.0%</td> <td></td> </tr> </table>	PID 6	12:54P	T.P: 5.0%		T.I: 120S		T.D: 30S		TOH: 100.0%		TOL: 0.0%		T.P / T.I / T.D : Temperature P, I, D value for PID 6 TOH, TOL : High/low value for temperature for MV
PID 6	12:54P												
T.P: 5.0%													
T.I: 120S													
T.D: 30S													
TOH: 100.0%													
TOL: 0.0%													

Symbol	Parameter	Range	Display	Unit	Default	Edit
TEMP.RP1	TEMP REFERENCE1	0.1 ~ 99.9 %	Always	ABS	50.0%	O
TEMP.RP2	TEMP REFERENCE2	T.EU (0.0+1digit ~100.0- 1digit)	Always	T.EU	T.EU (100%/2)	O
HUMI.RP	HUMI REFERENCE	H.EU(0.0 ~100.0)	Always	H.EU	H.EU (100%/2)	O
T.P	PROPORTIONAL BAND	0.1 ~ 999.9	Display	ABS	5.0	O
T.I	TEMP INTEGRAL	0 ~ 6000	Display	ABS	120	O
T.D	DERIVATIVE TIME	0 ~ 6000	Display	ABS	30	O
TOH	TEMP OUTPUT LIMIT HIGH	T.OL+1digit ~ 100.0	Display	ABS	100.0	O
T.OL	TEMP OUTPUT LIMIT LOW	0.0 ~ T.OH-1digit	Display	ABS	0.0	O
H.P	PROPORTIONAL BAND	0.1 ~ 999.9	Display	ABS	5.0	O
H.I	HUMI INTEGRAL	0 ~ 6000	Display	ABS	120	O
H.D	DERIVATIVE TIME	0 ~ 6000	Display	ABS	30	O
HOH	HUMI OUTPUT LIMIT HIGH	0.0 ~ 100.0	Display	ABS	100.0	O
HOL	HUMI OUTPUT LIMIT LOW	0.0 ~ 100.0	Display	ABS	0.0	O

### 4.5 TROUBLE SHOOTING

<b>TROUBLE</b>	<b>12:54P</b>	If the system, which this controller (NOVA series) adapted, has troubles (if you used DI2~DI4), the page appear also display WARN at the item state as picture You must solve the error before reusing the controller, otherwise you are reach error again. The controller is being the STOP mode automatically when error occur
ERROR 02 :	OK	
ERROR 03 :	OK	
ERROR 04 :	WARN	
<b>OCCUR TIME: 12:54P</b>		



NOTE

Ref 4.4.8 DI NAME for change TROUBLE(DI ERROR) NAME

# 5. Installation

## 5.1 Dimension & Panel Cutting Size

(Unit : mm)

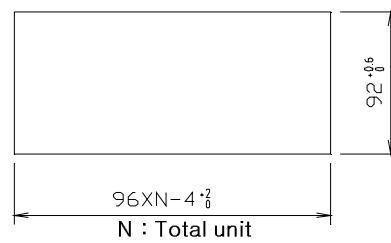
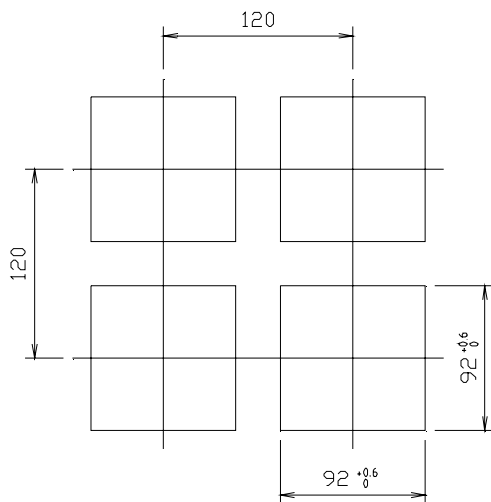
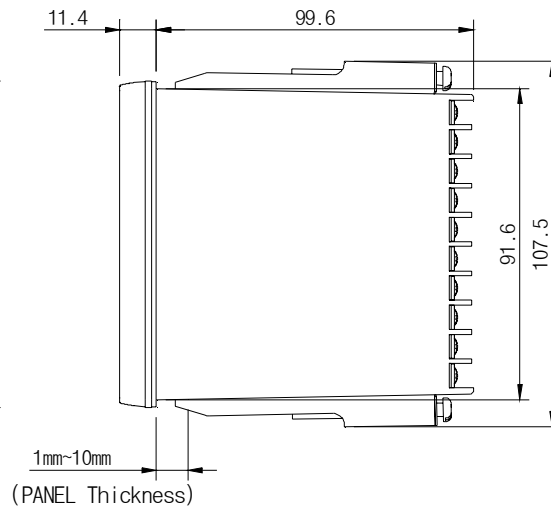
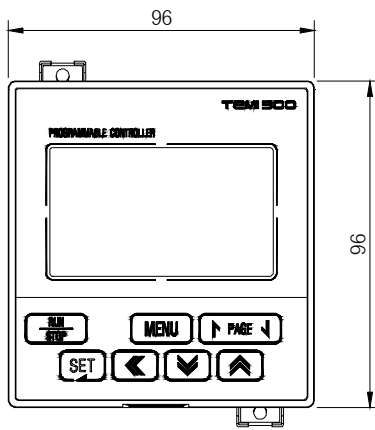
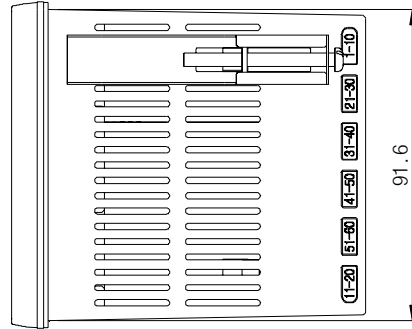



## 5.2 How to install Mount

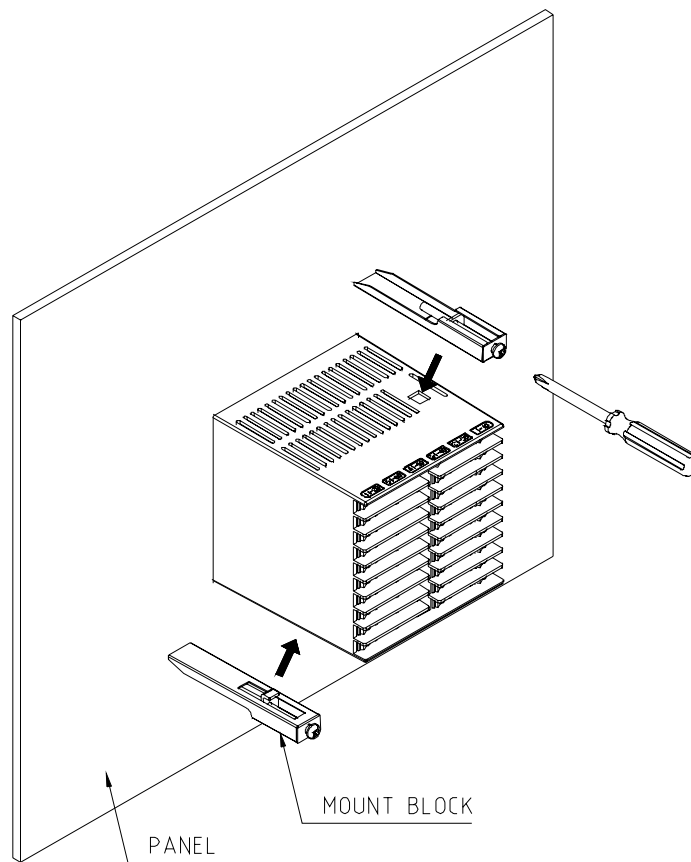

- 1) Cut the mounting panel as Section 5.1 PANEL CUTTING
- 2) Insert the unit from its back terminal board side
- 3) Attach the left and right brackets to the unit to fix the unit to the mounting panel. (Use screwdriver)



Do not tighten the mounting screw excessively, or the unit case or bracket may be damage

---

### 5.3 Power Cable Specification

Applicable power source cable : Vinyl insulation cable KSC 3304 0.9~2.0 mm<sup>2</sup>

### 5.4 Terminal Specification

Please use-tightening torque with insulating sleeve for M3.5 screws as shown in the following Figure:

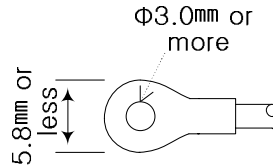

Note: When the screw is connected, its torque does not exceed 0.8 N·m.



#### CAUTION

- ▶ Before carrying out wiring, turn off the power to the controller and check that the cables to be connected are not alive with a tester or the like because there is a possibility of electric shock.
- ▶ The controller must be wired directly from circuit breaker output on inside of temperature & humidity Chamber for avoid damage of controller or chamber.



Avoid unused terminal for install, it might make damage to system or out of order.

---

### 5.5 Terminal Arrangement and External Wiring

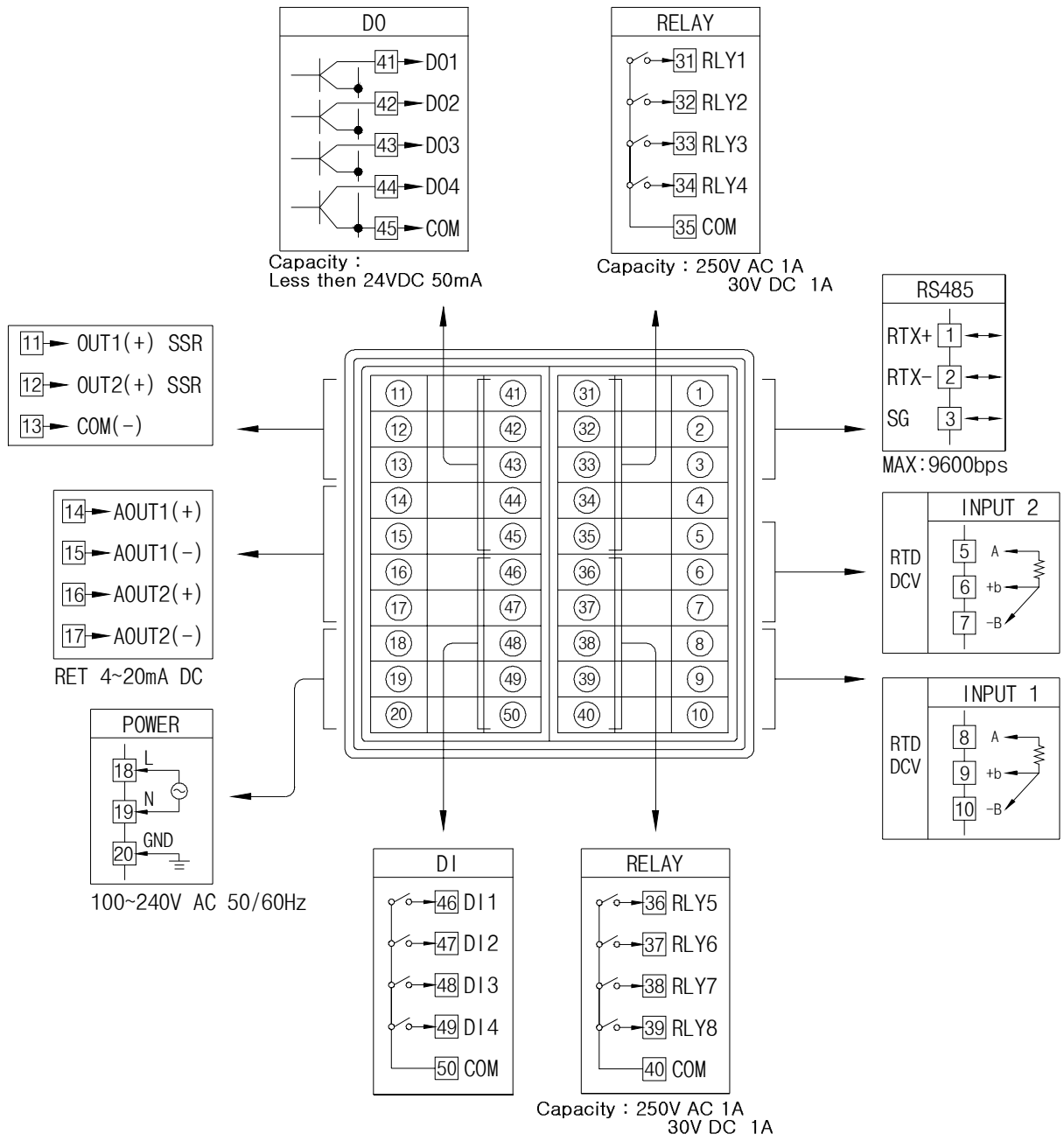

## 5.6 Grounding and Power Cable Connection

- Use a cable 2 mm<sup>2</sup> or more thick for grounding with class 3 grounding (grounding resistance a 100Ω or less) or higher. Do not extend the grounding cable over 20m.
- Ground from the ground terminal with a one-point contact.  
Do not wire between ground terminals.
- Use appropriate cables equivalent to vinyl insulation cable(KSC 3304) or more.

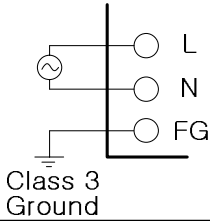

- ▶ Ground FRAME GROUND (FG) exactly
- ▶ For power source wiring, keep the L, N correctly otherwise it might make damage to system or broken the controller.



Before starting analog input wiring, be sure to turn off the system otherwise you might get an electrical shock.



- ▶ When connection, do not mix up the input polarity.
- ▶ Connecting with the wrong polarity can cause the unit to malfunction.
- ▶ For input wiring, use a shielded cable.
- ▶ Ground the shield at one point and grounding circuits as possible.
- ▶ Sensor input line must have avoid power source cable for protect noise.
- ▶ Use the cable that does not have any resistance difference and cable resistance.

## 5.7 Analog Input Connection

(A) RTD INPUT

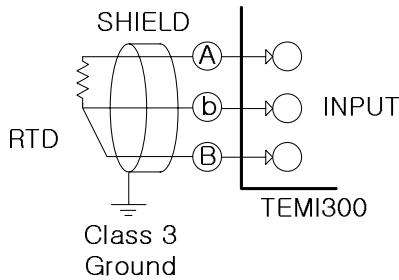

(B) DC VOLTAGE INPUT

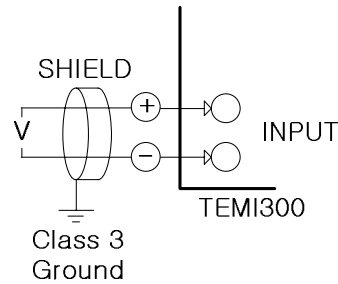

(C) DC CURRENT INPUT

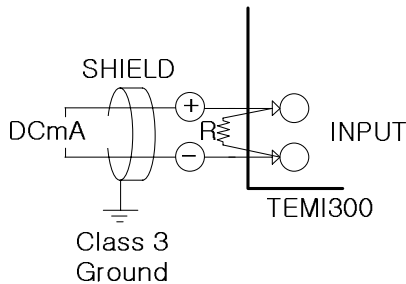

## 5-8 Analog Output Connection



Before starting analog output wiring, be sure to turn off the system or else you will get an electrical shock



- ▶ When connection, do not mix up the input polarity
- ▶ Connecting with the wrong polarity can cause the unit to malfunction
- ▶ For input wiring, use a shielded cable
- ▶ Ground the shield at one point and grounding circuits as possible

### (A) SSR

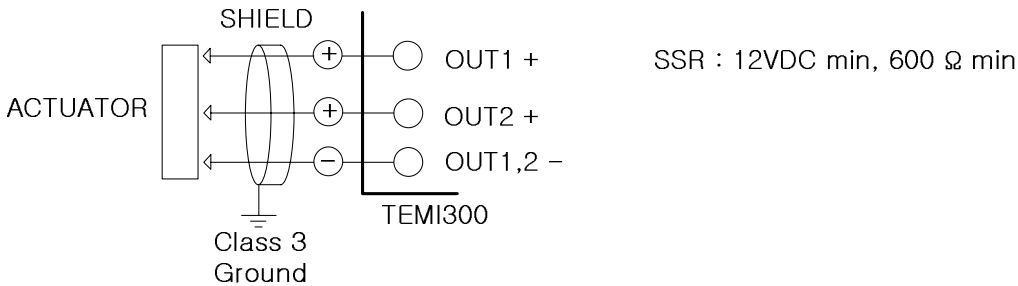

- ▶ Before starting ACTUATOR install/uninstall wiring, be sure to turn off the TEMI300 or else you will get an electrical shock.

### (B) RETRANSMISSION

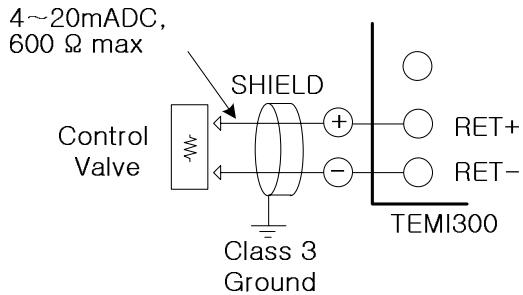

- ▶ Before starting receiver( or recorder, etc) install/uninstall wiring, be sure to turn off the TEMI 300 or else you will get an electrical shock.

### 5.9 External Contact Output Connection (RELAY)

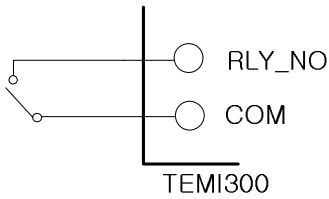

Before starting analog input wiring, be sure to turn off the system otherwise you might get an electrical shock.

### 5.10 External Contact Input Connection (DI)

- ▶ For the external contact, use a no-voltage contact (including relay contact) that can operate appropriately under the terminal voltage for a close contact (approximate.. 5V) and the current for a opened contact (approximate 1mA).
- ▶ When using an open collector, select one with the 2V or less voltage for the closed contact, and 100µA or less leakage current for the open contact.

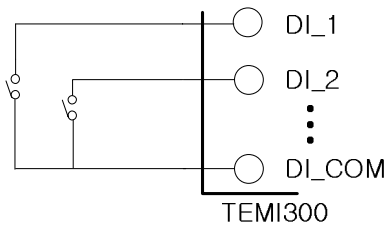

▲ RELAY contact input

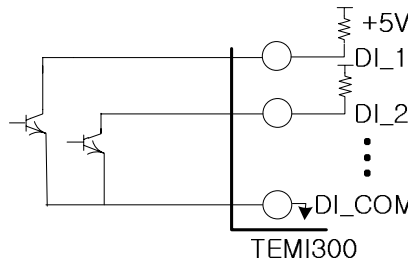

▲ TRANSISTOR contact input



Before starting analog input wiring, be sure to turn off the system otherwise you might get an electrical shock.

### 5.11 Use an Auxiliary Relay

- If you INDUCTANCE(L) load like as AUXILIARY RELAY or SOLENOIDE VALVE, it might make go to wrong or out of order relay, please make sure insert to parallel circuit with CR FILTER(AC) or DIODE(DC) by SURGE SUPPRESSOR of avoiding sparks.
- Recommend CR FILTER
  - ▶ Sung Ho Electronics : BSE104R120 25V (0.1µ+120Ω)
  - ▶ Hana Parts Co. : HN2EAC
  - ▶ Songmi Electric Co., Ltd. : CR UNIT 953, 955 etc
  - ▶ JiwoI Electric Co., Ltd. : SKV, SKVB etc
  - ▶ Shinyoung Communication Co., Ltd. : CR-CFS, CR-U etc



If contact capacity is over owns specification, use auxiliary relay for ON/OFF load.

(A) DC RELAY

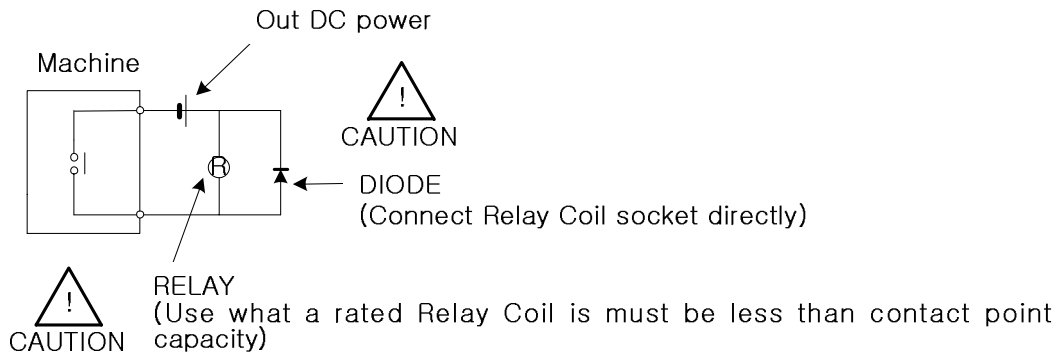

(B) AC RELAY

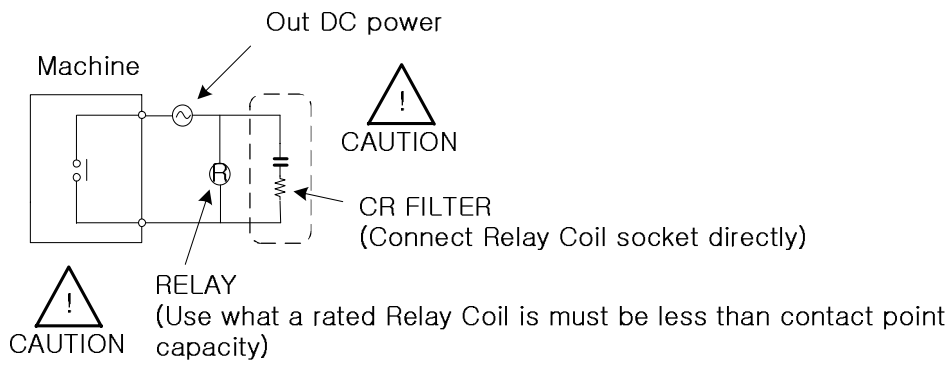

## 1. Communication Overview

TEMI300 is designed to establish a communication between upper-level computer and display via RS485 communication interface up to 31set.

As below, there are some parameters when the TEMI 300 communicates.

Parameter	Value	Description
PROTOCOL	0	Basic Protocol
	1	Basic Protocol + Check Sum
	2	MODBUS ASCII
	3	MODBUS RTU
TRANSMISSION RATE(BPS)	4	9600 bps
	3	4800 bps
	2	2400 bps
	1	1200 bps
PARITY	0	None Parity
	1	Even Parity
	2	Odd Parity
DATA LENGTH	8	8 bits
	7	7 bits
ADDRESS	1 ~ 99	Address
RESPONSE TIME	0 ~ 10	Processing time + Response*10msec

### ■ Default parameter of communication

- PROTOCOL : 1(Basic Protocol + Check Sum)
- BPS : 4(9600 bps)
- PARITY : 0(None Parity)
- DATA LENGTH : 8(8 bits)
- ADDRESS : 1
- RESPONSE : 0(Processing time + 10 msec)



## 2. wiring for Communication

TEMI 300 communication terminal arrangement is as below

### 2.1 RS485 Interface Connection with TEMI 300

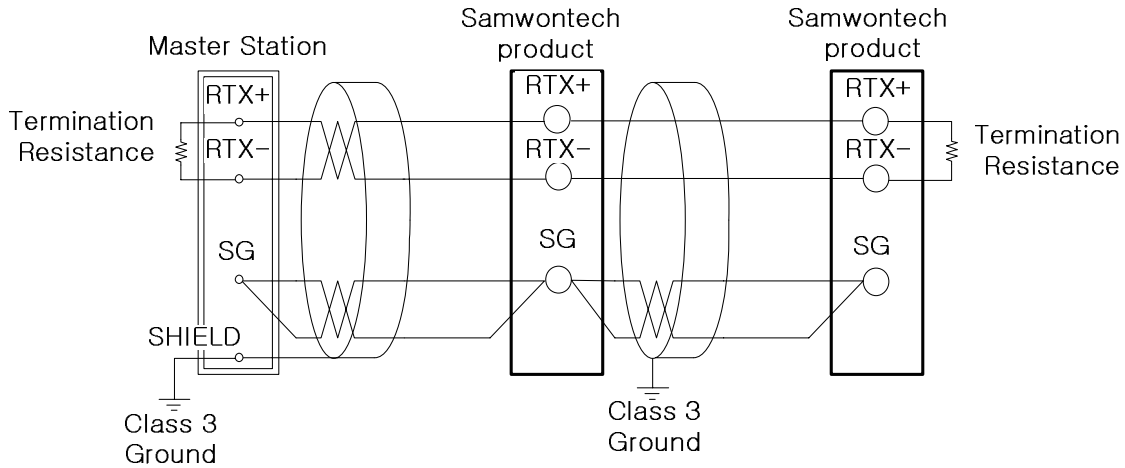

- The slave TEMI 300 could be connected up to 31set (MULTIDROP)
- Termination (200Ω 1/4W) resistance must be connected on the both part of edge



Before starting analog input wiring, be sure to turn off the system otherwise you might get an electrical shock.

### 3. Configuration of Command

#### 3.1 Consist of Command

It is basic communication command structure between upper-level computer and TEMI 300

①	②	③	④	⑤	⑥	⑦	⑧
S T X	ADDRESS	COMMAND	,	DATA by COMMAND	SUM	C R	L F

① Command start of text

This code indicates the start of a command string with 0x02

② ADDRESS

TEMI 300 communication address to identify the instruments

③ COMMAND

Specify the command from an upper device. (See 3.2~3.9)

④ ',' (Separation character)

Character for separating command and data by ','

⑤ Data

Data by Command rule

⑥ Check Sum

Display bottom 2-byte by Hexadecimal what the Sum with Ascii code from the next character of STX to the before character of SUM and only used when the PROTOCOL is type 1 + Check Sum on the TEMI 300

⑦, ⑧ CR, LF

This control code indicates the end of a command

### 3.2 Communication Commands

There are two kinds of commands, Self-information and Read/Write commands in the TEMI 300

① Self-information command

Command	Process
AMI	Model name & Version

② Read/Write Command

Command	Process
RSD	Reading D-Register orderly
RRD	Reading D-Register Random
WSD	Writing D-Register orderly
WRD	Writing D-Register Random
STD	Registration Random data of D-Register
CLD	Call D-Register of STD

Each command can read/write up to 32 D-Register and the all of the STD/CLD data will be reset when the power off, so the data should be resisted again

### 3.3 Error Response

The message when the communication error with TEMI 300

Byte	1	2	2	2	2	1	1
Command element	S T X	Address	NG	Number of word(2)	SUM	C R	L F

※ SUM is only using when the PROTOCOL is '1'

### 3.4 RSD Command

This command for reading D-Register orderly

■ Transmission format

Byte	1	2	3	1	2	1	4	2	1	1
Command element	S T X	Addr	RSD	,	Parameter number	,	D-Reg.NO.	SUM	C R	L F

■ Response

Byte	1	2	3	1	2	1	4	1	4	1	...
Command element	S T X	Addr	RSD	,	OK	,	dddd-1	,	dddd-2	,	...

1	4	1	4	2	1	1
,	dddd-(n-1)	,	dddd-(n)	SUM	C R	L F

- Parameter number : 1 ~ 32
- dddd : Indicates a character string in hexadecimal format

Ex) When reading the D-Register from Temp PV(D0001) to Temp SP(D0002)

- Transmission : [stx]01RSD,02,0001[cr][lf]
- Transmission (Include Check Sum) : [stx]01RSD,02,0001C5[cr][lf]
- ([stx] = 0x02, [cr] = 0x0d, [lf] = 0x0a)

Ex) The receiving data value are PV=50.0, SP=30.0, these data is receiving as blows,

- Transmission : [stx]01RSD,OK,01F4,012C[cr][lf]
- Transmission (Include Check Sum) : [stx]01RSD,OK,01F4,012C19[cr][lf]

※How to display and convert for receiving hexadecimal format PV data

- ① Convert decimal format : 01F4 (hexadecimal format) → 500 (decimal format)
- ② Result X 0.1 : 500 \* 0.1 → 50.0

### 3.5 RRD Command

This command for reading D-Register random

■ Transmission Format

Byte	1	2	3	1	2	1	4	1	4	1	...
Command element	S T X	Addr	RRD	,	Para meter numb er	,	D-Reg.No1	,	D-Reg.No2	,	...

1	4	1	4	2	1	1
,	D-Reg.No(n-1)	,	D-Reg.No(n)	SUM	C R	L F

■ Response

Byte	1	2	3	1	2	1	4	1	4	1	...
Command element	S T X	Addr	RRD	,	OK	,	dddd-1	,	dddd-2	,	...

1	4	1	4	2	1	1
,	dddd-(n-1)	,	dddd-(n)	SUM	C R	L F

- Parameter number : 1 ~ 32
- dddd : Indicates a character string in hexadecimal format

Ex) When reading the D-Register from PV(D0001), SP(D0002)

- Transmission : [stx]01RRD,02,0001,0002[cr][lf]
- Transmission (Include Check Sum) : [stx]01RRD,02,0001,0002B2[cr][lf]

D0001 = 50.0, D0002 = 30.0

- Transmission : [stx]01RRD,OK,01F4,012C[cr][lf]
- Transmission (Include Check Sum) : [stx]01RRD,OK,01F4,012C18[cr][lf]

### 3.6 WSD Command

This command for writing D-Register orderly

■ Transmission Format

Byte	1	2	3	1	2	1	4	1	4	1	...
Command element	S T X	Addr	WSD	,	Parameter number	,	D-Reg.No1	,	D-Reg.No2	,	...

1	4	1	4	2	1	1
,	D-Reg.No(n-1)	,	D-Reg.No(n)	SUM	C R	L F

■ Response

Byte	1	2	3	1	2	2	1	1
Command element	S T X	Addr	WSD	,	OK	SUM	C R	L F

- Parameter number : 1 ~ 32

- dddd : Indicates a character string in hexadecimal format

Ex) When reading the D-Register from Temp SP(D0102), Humi SP(D0103)

- Temp SP set : 50.0°C → Delete decimal point (500) → hexadecimal format(0x01F4)
- Humi SP set : 80.0°C → Delete decimal point (800) → hexadecimal format(0x0320)
- Transmission : [stx]01WSD,02,0102,01F4,0320[cr][lf]
- Transmission (Include Check Sum) : [stx]01WSD,02,0102,01F4,0320C4[cr][lf]

### 3.7 WRD Command

This command for writing D-Register random

■ Transmission Format

Byte	1	2	3	1	2	1	4	1	4	1	...
Command element	S T X	Addr	WRD	,	Para meter numb er	,	D-Reg.No1	,	D-Reg.No2	,	...

1	4	1	4	2	1	1
,	D-Reg.No(n-1)	,	D-Reg.No(n)	SUM	C R	L F

■ Response

Byte	1	2	3	1	2	2	1	1
Command element	S T X	Addr	WRD	,	OK	SUM	C R	L F

- Parameter number : 1 ~ 32

- dddd : Indicates a character string in hexadecimal format

Ex) When fix running, writing on Temp SP(D0102), Temp slope(D0106)

- Temp SP set : 50.0°C → Delete decimal point (500) → hexadecimal format(0x01F4)

- Temp slope set : 0.5°C → Delete decimal point (5) → hexadecimal format(0x0005)

- Transmission : [stx]01WRD,02,0102,01F4,0106,0005[cr][lf]

- Transmission (Include Check Sum) : [stx]01WRD,02,0102,01F4,0106,0005B5[cr][lf]

### 3.8 STD Command

This command is register D-register which you want to using at the TEMI 300

■ Transmission Format

Byte	1	2	3	1	2	1	4	1	4	1	...
Command element	S T X	Addr	STD	,	Para meter numb er	,	D-Reg.No1	,	D-Reg.No2	,	...

1	4	1	4	2	1	1
,	D-Reg.No(n-1)	,	D-Reg.No(n)	SUM	C R	L F

■ Response

Byte ⇄	1	2	3	1	2	2	1	1
Command element	S T X	Addr	STD	,	OK	SUM	C R	L F

- Parameter number : 1 ~ 32

Ex) For Regist PV(D0001), SP(D0002)

- Transmission : [stx]01STD,02,0001,0002[cr][lf]
- Transmission (Include Check Sum) : [stx]01STD,02,0001,0002B5[cr][lf]



### 3.9 CLD Command

This command is reading D-register, which was resisted by STD Command at the TEMI 300

■ Transmission Format

Byte	1	2	3	2	1	1
Command element	S T X	Addr	CLD	SUM	C R	L F

■ Response

Byte	1	2	3	1	2	1	4	1	4	1	...
Command element	S T X	Addr	CLD	,	OK	,	dddd-1	,	dddd-2	,	...

1	4	1	4	2	1	1
,	dddd-(n-1)	,	dddd-(n)	SUM	C R	L F

- Parameter number : 1 ~ 32

- dddd : Indicates a character string in hexadecimal format

Ex) When the reading the D-Register that regist on STD Command

- Transmission : [stx]01CLD[cr][lf]
- Transmission (Include Check Sum) : [stx]01CLD34[cr][lf]

## 4. D-REGISTER

D-Register is group of data which can using with communication all of TEMI 300s condition. Each group has 100 registers and these are classified as follows:

D-Register Range	Group	Description	Read	Write
D0001 ~ D0099	PROCESS	BASIC PROCESS DISPLAY	○	×
D0100 ~ D0199	FUNCTION	OPERATION INFO DISPLAY	○	○
D0200 ~ D0299	RESERVATION	TIME & RESERVATION	○	△
D0300 ~ D0399	IS	INNER SIGNAL	○	○
D0400 ~ D0499	ALARM	ALARM	○	○
D0500 ~ D0599	TEMP_PID	TEMP P.I.D	○	○
D0600 ~ D0699	HUMI_PID	HUMI P.I.D	○	○
D0700 ~ D0799	COMM	COMMUNICATION	○	×
D0800 ~ D0899	OUTPUT	CONTROL OUTPUT	○	○
D0900 ~ D0999	IINPUT	INPUT	○	○
D1000 ~ D1099	PROGRAM	PROGRAM PATTERN	○	○
D1100 ~ D1199	PROG_INFO1	SEGMENT TEMP SP	○	○
D1200 ~ D1299	PROG_INFO2	SEGMENT HUMI SP	○	○
D1300 ~ D1399	PROG_INFO3	SEGMENT TIME SET	○	○
D1400 ~ D1499	PROG_INFO4	SEGMENT TIME SIGNAL1	○	○
D1500 ~ D1599	PROG_INFO5	SEGMENT TIME SIGNAL2	○	○
D1600 ~ D1699	PROG_INFO6	SEGMENT WAIT	○	○
D1700 ~ D1799	ON/OFF	ON/OFF SIGNAL	○	○

Each D-Registers are consisted hexadecimal 4charater(2-Byte)

## 4.1 PROCESS

Process group has basic data. It has Bit Map (Display data by Bit) as follow;

Bit	NOW_STS (D0010)	IS_STS (D0012)	TS_STS (D0013)	AL_STS (D0014)	UO_STS (D0016)
0	RESET	INNER SIGNAL 1	TIME SIGNAL 1	ALARM 1	RELAY 1
1	FIX_RUN	INNER SIGNAL 2	TIME SIGNAL 2	ALARM 2	RELAY 2
2	PROG_RUN	INNER SIGNAL 3		ALARM 3	RELAY 3
3	PROG_HOLD	INNER SIGNAL 4		ALARM 4	RELAY 4
4	PROG_WAIT	INNER SIGNAL 5			RELAY 5
5	TEMP AT	INNER SIGNAL 6			RELAY 6
6	HUMI AT				RELAY 7
7					RELAY 8
8					RELAY 9
9					RELAY 10
10					RELAY 11
11					RELAY 12
12					
13					
14					
15					

It is consist D-Register which has usable data except above Bit Map INFO

■ Share running D-Register

D-Register	Symbol	Description
D0001	TEMP_NPV	PRESENT TEMP PV
D0002	TEMP_NSP	PRESENT TEMP SP
D0003	WET_NPV	PRESENT WEB VERB TEMP PV
D0004	WET_NSP	PRESENT WEB VERB TEMP SP
D0005	HUMI_NPV	PRESENT HUMI PV
D0006	HUMI_NSP	PRESENT HUMI SP
D0007	TEMP_MVOUT	TEMP MV OUTPUT
D0008	HUMI_MVOUT	HUMI MV OUTPUT
D0009	C_PIDNO	PRESENT RUNNING P.I.D NO.

■ FIX running D-Register

D-Register	Symbol	Description
D0020	PROC_TIME_H	FIX RUNNING PROCESS_TIME(HOUR)
D0021	PROC_TIME_M	FIX RUNNING PROCESS_TIME(MIN)

■ Share running D-Register

D-Register	Symbol	Description
D0025	RUN_PTNO	PRESENT RUNNING PROGRAM PATTERN NO.
D0026	RUN_SEGNO	PRESENT RUNNING SEGMENT NO.
D0027	REMAIN_TIME_H	PRESENT RUNNING SEGMENT REMAIN TIME (HOUR)
D0028	REMAIN_TIME_M	PRESENT RUNNING SEGMENT REMAIN TIME (MIN)
D0029	WAIT_TIME_H	WAIT TIME(HOUR)
D0030	WAIT_TIME_M	WAIT TIME(MIN)
D0031	NOW_PT_RPT	PRESENT RUNNING PATTERN REPEAT NO. OF TIME
D0032	TOTAL_PT_RPT	SET PATTERN REPEAT NO. OF TIME
D0035	PREV_TEMP_TSP	PREVIOUS SEGMENT TEMP TSP (TARGET SET POINT)
D0036	NOW_TEMP_TSP	PRESENT SEGMENT TEMP TSP (TARGET SET POINT)
D0037	PREV_HUMI_TSP	PREVIOUS SEGMENT HUMI TSP (TARGET SET POINT)
D0038	NOW_HUMI_TSP	PRESENT SEGMENT HUMI TSP (TARGET SET POINT)
D0039	NOW_SEG_TIME	PRESENT SEGMENT SET TIME

## 4.2 FUNCTION

FUNCTION is consisted D-Register for operation

### ■ PROGRAM Running D-Register

D-Register	Symbol	Description
D0100	SET_PTNO	Program pattern number for running
D0122	TEMP_WAIT_ZONE	Temp wait zone
D0123	HUMI_WAIT_ZONE	Humi wait zone
D0124	WAIT_TIME	Wait time

### ■ FIX running D-Register

D-Register	Symbol	Description
D0102	FIX_TEMP_SP	SET TEMP SP ON FIX RUNNING
D0103	FIX_HUMI_SP	SET HUMI SP ON FIX RUNNING
D0106	TEMP_SLOPE	SET TEMP SLOPE SP ON FIX RUNNING
D0107	HUMI_SLOPE	SET HUMI SLOPE SP ON FIX RUNNING
D0110	FIX_OPTM_SELL	ON/OFF FOR FIX OP TIME(0 : OFF, 1 : ON)
D0111	FIX_OPTM_H	FIX OP TIME (HOUR)
D0112	FIX_OPTM_M	FIX OP TIME (MIN)

### ■ AT(AUTO TUNING) D-Register

D-Register	Symbol	Description
D0113	TEMP_TUNE	TEMP AT
D0114	HUMI_TUNE	HUMI AT

### ■ PID Setting D-Register

D-Register	Symbol	Description
D0108	FUZZY	FUZZY FUNCTION
D0115	TEMP_RHY	TEMP REFERENCE HYSTERESIS
D0116	TEMP_RP1	TEMP REFERENCE 1
D0117	TEMP_RP2	TEMP REFERENCE 2
D0118	HUMI_RP	HUMI REFERENCE
D0120	HUMI_RHY	HUMI REFERENCE HYSTERESIS

■ Operation D-Register

D-Register	Symbol	State	Value	Description
D0101	STATUS_MODE	RUN	1	PROG/FIX RUN
		HOLD	2	HOLD ON/OFF
		STEP	3	SEGMENT STEP
		STOP	4	PROG/FIX STOP
D0104	OPMODE	PROG	0	PROG MODE
		FIX	1	FIX MODE
D0105	PWRMODE	STOP	0	STOP MODE
		COLD	1	COLD MODE
		HOT	2	HOT MODE

For PROG RUN's (or FIX RUN) through communication,

TEMI 300 must be STOP(PROG STOP/FIX STOP)

Ex) TEMI 300 should be PROG STOP(D0104 = 0001, D0101 = 0004)

for switching FIX RUN TO PROG RUN

### 4.3 RESERVATION

RESERVATION group is consisted confirm time, setting & reservation time D-Register

■ Setting Time D-Register

D-Register	Symbol	Description	Read	Write
D0201	NOW_YEAR	PRESENT TIME (YEAR)	○	×
D0202	NOW_MONTH	PRESENT TIME (MONTH)	○	×
D0203	NOW_DAY	PRESENT TIME (DAY)	○	×
D0204	NOW_HOUR	PRESENT TIME (HOUR)	○	×
D0205	NOW_MIN	PRESENT TIME (MIN)	○	×
D0206	RUN_YEAR	RESERVE TIME (YEAR)	○	○
D0207	RUN_MONTH	RESERVE TIME (MONTH)	○	○
D0208	RUN_DAY	RESERVE TIME (DAY)	○	○
D0209	RUN_HOUR	RESERVE TIME (HOUR)	○	○
D0210	RUN_MIN	RESERVE TIME (MIN)	○	○
D0211	SET_YEAR	PRESENT TIME (YEAR)	×	○
D0212	SET_MONTH	PRESENT TIME (MONTH)	×	○
D0213	SET_DAY	PRESENT TIME (DAY)	×	○
D0214	SET_HOUR	PRESENT TIME (HOUR)	×	○
D0215	SET_MIN	PRESENT TIME (MIN)	×	○

■ Reservation ON/OFF

D-Register	Symbol	State	Value	Description
D0200	RESERVE	OFF	0	Reserve Off
		ON	1	Reserve On

## 4.4 IS/ALARM

IS & ALARM group is consisted Inner D-Register for Signal & Alarm setting

### ■ Setting IS D-Register

D-Register	Symbol	Description
D0305	IS1_BAND	IS1 RANGE DIRECTION
D0306	IS1_KIND	IS1 RUNNING ITEM
D0307	IS1_HIGH	IS1 RANGE HIGH
D0308	IS1_LOW	IS1 RANGE LOW
D0309	IS1_DELAY_TM	IS1 DELAY TIME
⋮	⋮	⋮
D0330	IS6_BAND	IS6 RANGE DIRECTION
D0331	IS6_KIND	IS6 RUNNING ITEM
D0332	IS6_HIGH	IS6 RANGE HIGH
D0333	IS6_LOW	IS6 RANGE LOW
D0334	IS6_DELAY_TM	IS6 DELAY TIME

### ■ Setting ALARM D-Register

D-Register	Symbol	Description
D0400	AL1_ITEM	ALARM 1 ADAPT POINT
...	...	...
D0403	AL4_ITEM	ALARM 4 ADAPT POINT
D0405	AL1_KIND	ALARM 1 ITEM
...	...	...
D0408	AL4_KIND	ALARM 4 ITEM
D0410	AL1_POINT	ALARM 1 POINT
...	...	...
D0413	AL4_POINT	ALARM 4 POINT
D0415	AL1_HYS	ALARM 1 HYSTERESIS
...	...	...
D0418	AL4_HYS	ALARM 4 HYSTERESIS
D0420	AL1_DELAY_TM	ALARM 1 DELAY TIME
...	...	...
D0423	AL4_DELAY_TM	ALARM 4 DELAY TIME



## 4.5 PID

PID GROUP is consisted D-Register for setting PID

■ Setting PID D-Register

D-Register	Symbol	Description
D0500	TEMP_PB1	PROPORTIONAL OPERATION TIME FOR TEMP PID1 CONTROL
D0501	TEMP_TI1	INTEGRATION TIME FOR TEMP PID1 CONTROL
D0502	TEMP_TD1	DERIVATION TIME FOR TEMP PID1 CONTROL
D0503	TEMP_OH1	THE HIGH RANGE OF TEMP PID 1
D0504	TEMP_OL1	THE LOW RANGE OF TEMP PID 1
D0505	TEMP_MR1	MANUAL SET VALUE APPLY TO TEMP PID1
⋮	⋮	⋮
D0530	TEMP_PB6	PROPORTIONAL OPERATION TIME FOR TEMP PID6 CONTROL
D0531	TEMP_TI6	INTEGRATION TIME FOR TEMP PID 6 CONTROL
D0532	TEMP_TD6	DERIVATION TIME FOR TEMP PID 6 CONTROL
D0533	TEMP_OH6	THE HIGH RANGE OF TEMP PID 6
D0534	TEMP_OL6	THE LOW RANGE OF TEMP PID 6
D0535	TEMP_MR6	MANUAL SET VALUE APPLY TO TEMP PID 6
D0500	HUMI_PB1	PROPORTIONAL OPERATION TIME FOR TEMP PID 1 CONTROL
D0601	HUMI_TI1	INTEGRATION TIME FOR TEMP PID 1 CONTROL
D0602	HUMI_TD1	DERIVATION TIME FOR TEMP PID 1 CONTROL
D0603	HUMI_OH1	THE HIGH RANGE OF TEMP PID 1
D0604	HUMI_OL1	THE LOW RANGE OF TEMP PID 1
D0605	HUMI_MR1	MANUAL SET VALUE APPLY TO TEMP PID 1
⋮	⋮	⋮
D0630	HUMI_PB6	PROPORTIONAL OPERATION TIME FOR TEMP PID 6 CONTROL
D0631	HUMI_TI6	INTEGRATION TIME FOR TEMP PID 6 CONTROL
D0632	HUMI_TD6	DERIVATION TIME FOR TEMP PID 6 CONTROL
D0633	HUMI_OH6	THE HIGH RANGE OF TEMP PID 6
D0634	HUMI_OL6	THE LOW RANGE OF TEMP PID 6
D0635	HUMI_MR6	MANUAL SET VALUE APPLY TO TEMP PID 6

## 4.6 OUTPUT

OUTPUT GROUP is consisted D-Register for setting Control Output

### ■ Setting OUTPUT D-Register

D-Register	Symbol	Description
D0800	TEMP_OT	TEMP OUTPUT TYPE
D0801	TEMP_DR	TEMP DIRECTION
D0802	TEMP_CT	TEMP CYCLE
D0803	TEMP_ARW	TEMP ARW
D0806	TEMP_ATGAIN	TEMP AT GAIN
D0807	TEMP_ATGAIN	HUMI AT GAIN
D0810	HUMI_OT	HUMI OUTPUT TYPE
D0811	HUMI_DR	HUMI DIRECTION
D0812	HUMI_CT	HUMI CYCLE
D0813	HUMI_ARW	HUMI ARW
D0816	TEMP_RET_KIND	TEMP RETRANSMISSION TYPE
D0817	TEMP_RET_RL	TEMP RETRANSMISSION LOW RANGE
D0818	TEMP_RET_RH	TEMP RETRANSMISSION HIGH RANGE
D0821	HUMI_RET_KIND	HUMI OUTPUT TYPE
D0822	HUMI_RET_RL	HUMI RETRANSMISSION LOW RANGE
D0823	HUMI_RET_RH	HUMI RETRANSMISSION HIGH RANGE
D0840	DOCON_IS1	INNER SIGNAL1 CONTACT OUTPUT
...	...	...
D0845	DOCON_IS6	INNER SIGNAL6 CONTACT OUTPUT
D0846	DOCON_TS1	TIME SIGNAL1 CONTACT OUTPUT
D0847	DOCON_TS2	TIME SIGNAL2 CONTACT OUTPUT
D0848	DOCON_AL1	ALARM SIGNAL1 CONTACT OUTPUT
...	...	...
D0851	DOCON_AL4	ALARM SIGNAL4 CONTACT OUTPUT
D0852	DOCON_TRUN	TEMP RUN CONTACT OUTPUT
D0853	DOCON_HRUN	HUMI RUN CONTACT OUTPUT
D0854	DOCON_T1	T1 SIGNAL1 CONTACT OUTPUT
...	...	...
D0857	DOCON_T4	T4 SIGNAL4 CONTACT OUTPUT

D-Register	Symbol	Description
D0858	DOCON_H1	H1 SIGNAL CONTACT OUTPUT
D0859	DOCON_T1TM	T1 SIGNAL TIME
...	...	...
D0862	DOCON_T4TM	T4 SIGNAL TIME
D0863	DOCON_H1TM	H1 SIGNAL TIME
D0864	DOCON_TUP	TEMP UP SIGNAL CONTACT OUTPUT
D0865	DOCON_TSK	TEMP SOAK SIGNAL CONTACT OUTPUT
D0866	DOCON_TDN	TEMP DOWN SIGNAL CONTACT OUTPUT
D0867	DOCON_TUP_P	TEMP UP SIGNAL
D0868	DOCON_TSK_P	TEMP SOAK SIGNAL TIME
D0869	DOCON_TDN_P	TEMP DOWN SIGNAL
D0870	DOCON_HUP	HUMI UP SIGNAL CONTACT OUTPUT
D0871	DOCON_HSK	HUMI SOAK SIGNAL CONTACT OUTPUT
D0872	DOCON_HDN	HUMI DOWN SIGNAL CONTACT OUTPUT
D0873	DOCON_HUP_P	HUMI UP SIGNAL
D0874	DOCON_HSK_P	HUMI SOAK SIGNAL TIME
D0875	DOCON_HDN_P	HUMI DOWN SIGNAL
D0876	DOCON_DRAIN	DRAIIN SIGNAL CONTACT OUTPUT
D0877	DOCON_ERR	ERROR SIGNAL CONTACT OUTPUT
D0878	DOCON_PTEND	PTEND SIGNAL CONTACT OUTPUT
D0879	DOCON_1REF	FIRST REFERENCE SIGNAL CONTACT OUTPUT
D0880	DOCON_2REF	SECOND REFERENCE SIGNAL CONTACT OUTPUT
D0881	DOCON_DRAIN_P	DRAIIN SIGNAL TIME
D0882	DOCON_ERR_P	ERROR SIGNAL TIME
D0883	DOCON_PTEND_P	PTEND SIGNAL TIME
D0884	DOCON_1REF_P	FIRST REFERENCE SIGNAL TIME
D0885	DOCON_2REF_P	SECOND REFERENCE SIGNAL TIME

## 4.7 INPUT

INPUT GROUP is consisted D-Register for setting Input

### ■ Setting INPUT D-Register

D-Register	Symbol	Description
D0900	TEMP_IN	TEMP INPUT TYPE
D0901	TEMP_RH	TEMP HIGH RANGE
D0902	TEMP_RL	TEMP LOW RANGE
D0904	TEMP_FILTER	TEMP FILTER
D0905	TEMP_SH	TEMP HIGH SCALE
D0906	TEMP_SL	TEMP LOW SCALE
D0908	HUMI_SH	HUMI HIGH SCALE
D0909	HUMI_SL	HUMI LOW SCALE
D0910	HUMI_IN	HUMI INPUT TYPE
D0911	HUMI_RH	HUMI HIGH RANGE
D0912	HUMI_RL	HUMI LOW RANGE
D0914	HUMI_FILTER	HUMI FILTER
D0940	DP_RL	TEMP REFERENCE BIAS RL
D0941	DP_P1	TEMP REFERENCE BIAS POINT1
D0942	DP_P2	TEMP REFERENCE BIAS POINT2
D0943	DP_RH	TEMP REFERENCE BIAS RH
D0944	DD_RL	TEMP BIAS VALUE OF RL
D0945	DD_P1	TEMP BIAS VALUE OF POINT1
D0946	DD_P2	TEMP BIAS VALUE OF POINT2
D0947	DD_RH	TEMP BIAS VALUE OF RH
D0950	WP_RL	WET TEMP REFERENCE BIAS RL
D0951	WP_RH	WET TEMP REFERENCE BIAS RH
D0952	WD_RL	WET TEMP BIAS VALUE OF RL
D0953	WD_RH	WET TEMP BIAS VALUE OF RH
D0960	RP_RL	HUMIDITY REFERENCE BIAS RL
D0961	RP_RH	HUMIDITY REFERENCE BIAS RH
D0962	RD_RL	HUMIDITY BIAS VALUE OF RL
D0963	RD_RH	HUMIDITY BIAS VALUE OF RH

## 4.8 PROGRAM

PROGRAM GROUP is consisted D-Register for setting Program Pattern

### ■ Setting PROGRAM PATTERN setting D-Register

D-Register	Symbol	Description
D1000	PT_SS1	PATTERN 1 START SEGMENT NO.
D1001	PT_ES1	PATTERN 1 END SEGMENT NO.
D1002	PT_RPT1	PATTERN 1 REPEAT NO. OF TIME
D1003	PT_JP1	PATTERN NO AFTER RUNNING PATTERN 1
⋮	⋮	⋮
D1090	PT_SS10	PATTERN 10 START SEGMENT NO.
D1091	PT_ES10	PATTERN 10 END SEGMENT NO.
D1092	PT_RPT10	PATTERN 10 REPEAT NO. OF TIME
D1093	PT_JP10	PATTERN NO AFTER RUNNING PATTERN 10
D1100	SEG_TSP1	PATTERN 1 TEMP SP
...	...	...
D1199	SEG_TSP100	PATTERN 100 TEMP SP
D1200	SEG_HSP1	PATTERN 1 HUMI SP
...	...	...
D1299	SEG_HSP100	PATTERN 100 HUMI SP
D1300	SEG_TM1	SEGMENT 1 TIME
...	...	...
D1399	SEG_TM100	SEGMENT 100 TIME
D1400	SEG_TS11	SEGMENT 1 TIME SIGNAL 1
...	...	...
D1499	SEG_TS1100	SEGMENT 100 TIME SIGNAL 1
D1500	SEG_TS21	SEGMENT 1 TIME SIGNAL 2
...	...	...
D1599	SEG_TS2100	SEGMENT 100 TIME SIGNAL 2
D1600	SEG_WT1	SEGMENT 1 WAIT
...	...	...
D1699	SEG_WT100	SEGMENT 100 WAIT

## 4.9 ON/OFF

ON/OFF GROUP is consisted D-Register for setting ON/OFF SIGNAL

### ■ Setting ON/OFF SIGNAL D-Register

D-Register	Symbol	Description
D1700	ONF_LOWSP_T1	LOW SP_T1
D1701	ONF_MIDSP_T1	MIDDLE SP_T1
D1702	ONF_HIGHSP_T1	HIGH SP_T1
D1703	ONF_DIFH_T1	HIGH DIFFERENCE_T1
D1704	ONF_DIFL_T1	LOW DIFFERENCE_T1
⋮	⋮	⋮
D1720	ONF_LOWSP_T3	LOW SP_T3
D1721	ONF_MIDSP_T3	MIDDLE SP_T3
D1722	ONF_HIGHSP_T3	HIGH SP_T3
D1723	ONF_DIFH_T3	HIGH DIFFERENCE_T3
D1724	ONF_DIFL_T3	LOW DIFFERENCE_T3
D1730	ONF_LOWSP_H1	LOW SP_H1
D1731	ONF_MIDSP_H1	MIDDLE SP_H1
D1732	ONF_HIGHSP_H1	HIGH SP_H1
D1733	ONF_DIFH_H1	HIGH DIFFERENCE_H1
D1734	ONF_DIFL_H1	LOW DIFFERENCE_H1

## D-Register 0000~0599

NO	PROCESS	FUNCTION	RESERVATION	IS	ALARM	TEMP_PID
	0	100	200	300	400	500
0		SET_PTNO	RESERVE		AL1_ITEM	TEMP_PB1
1	TEMP_NPV	STATUS_MODE	NOW_YEAR		AL2_ITEM	TEMP_TI1
2	TEMP_NSP	FIX_TEMP_SP	NOW_MONTH		AL3_ITEM	TEMP_TD1
3	WET_NPV	FIX_HUMI_SP	NOW_DAY		AL4_ITEM	TEMP_OH1
4	WET_NSP	OP_MODE	NOW_HOUR			TEMP_OL1
5	HUMI_NPV	PWR_MODE	NOW_MIN	IS1_BAND	AL1_KIND	TEMP_MR1
6	HUMI_NSP	TEMP_SLOPE	RUN_YEAR	IS1_KIND	AL2_KIND	TEMP_PB2
7	TEMP_MVOUT	HUMI_SLOPE	RUN_MONTH	IS1_HIGH	AL3_KIND	TEMP_TI2
8	HUMI_MVOUT	FUZZY	RUN_DAY	IS1_LOW	AL4_KIND	TEMP_TD2
9	C_PIDNO		RUN_HOUR	IS1_DELAY_TM		TEMP_OH2
10	NOW_STS	FIX_OPTM_SELL	RUN_MIN	IS2_BAND	AL1_POINT	TEMP_OL2
11		FIX_OPTM_H	SET_YEAR	IS2_KIND	AL2_POINT	TEMP_MR2
12	IS_STS	FIX_OPTM_M	SET_MONTH	IS2_HIGH	AL3_POINT	TEMP_PB3
13	TS_STS	TEMP_TUNE	SET_DAY	IS2_LOW	AL4_POINT	TEMP_TI3
14	AL_STS	HUMI_TUNE	SET_HOUR	IS2_DELAY_TM		TEMP_TD3
15	SYS_ERR_STS	TEMP_RHY	SET_MIN	IS3_BAND	AL1_HYS	TEMP_OH3
16	UO_STS	TEMP_RP1		IS3_KIND	AL2_HYS	TEMP_OL3
17		TEMP_RP2		IS3_HIGH	AL3_HYS	TEMP_MR3
18	DI_DATA	HUMI_RP		IS3_LOW	AL4_HYS	TEMP_PB4
19	ADERR_STS			IS3_DELAY_TM		TEMP_TI4
20	PROC_TIME_H	HUMI_RHY		IS4_BAND	AL1_DELAY_TM	TEMP_TD4
21	PROC_TIME_M			IS4_KIND	AL2_DELAY_TM	TEMP_OH4
22		TEMP_WAIT_ZONE		IS4_HIGH	AL3_DELAY_TM	TEMP_OL4
23		HUMI_WAIT_ZONE		IS4_LOW	AL4_DELAY_TM	TEMP_MR4
24		WAIT_TIME		IS4_DELAY_TM		TEMP_PB5
25	RUN_PTNO			IS5_BAND		TEMP_TI5
26	RUN_SEGNO			IS5_KIND		TEMP_TD5
27	REMAIN_TIME_H			IS5_HIGH		TEMP_OH5
28	REMAIN_TIME_M			IS5_LOW		TEMP_OL5
29	WAIT_TIME_H			IS5_DELAY_TM		TEMP_MR5
30	WAIT_TIME_M			IS6_BAND		TEMP_PB6
31	NOW_PT_RPT			IS6_KIND		TEMP_TI6
32	TOTAL_PT_RPT			IS6_HIGH		TEMP_TD6
33				IS6_LOW		TEMP_OH6

NO	PROCESS	FUNCTION	RESERVATION	IS	ALARM	TEMP_PID
	0	100	200	300	400	500
34				IS6_DELAY_TM		TEMP_OL6
35	PREV_TEMP_TSP					TEMP_MR6
36	NOW_TEMP_TSP					
37	PREV_HUMI_TSP					
38	NOW_HUMI_TSP					
39	NOW_SEG_TIME					
40						
41						
42						
43						
44						
45						
46						
47						
48						
49						
50						
51						
52						
53						
54						
55						
56						
57						
58						
59						
60						
61						
62						
63						
64						
65						
66						
67						
68						



NO	PROCESS	FUNCTION	RESERVATION	IS	ALARM	TEMP_PID
	0	100	200	300	400	500
69						
70						
71						
72						
73						
74						
75						
76						
77						
78						
79						
80						
81						
82						
83						
84						
85						
86						
87						
88						
89						
90						
91						
92						
93						
94						
95						
96						
97						
98						
99						

## D-Register 0600~1199

NO	HUMI_PID	COMM	OUTPUT	INPUT	PROGRAM	PROG_INFO1
	600	700	800	900	1000	1100
0	HUMI_PB1	PROTOCOL	TEMP_OT	TEMP_IN	PT_SS1	SEG_TSP1
1	HUMI_TI1	BAUD_RATE	TEMP_DR	TEMP_RH	PT_ES1	SEG_TSP2
2	HUMI_TD1	PARITY	TEMP_CT	TEMP_RL	PT_RPT1	SEG_TSP3
3	HUMI_OH1	STOP_BIT	TEMP_ARW	TEMP_BIAS	PT_JP1	SEG_TSP4
4	HUMI_OL1	DATA_LENGTH		TEMP_SH		SEG_TSP5
5	HUMI_MR1	ADDRESS		TEMP_SL		SEG_TSP6
6	HUMI_PB2	RESPONSE	TEMP_ATGAIN	TEMP_FILTER		SEG_TSP7
7	HUMI_TI2		HUMI_ATGAIN			SEG_TSP8
8	HUMI_TD2			HUMI_IN		SEG_TSP9
9	HUMI_OH2			HUMI_RH		SEG_TSP10
10	HUMI_OL2		HUMI_OT	HUMI_RL	PT_SS2	SEG_TSP11
11	HUMI_MR2		HUMI_DR	HUMI_BIAS	PT_ES2	SEG_TSP12
12	HUMI_PB3		HUMI_CT	HUMI_SH	PT_RPT2	SEG_TSP13
13	HUMI_TI3		HUMI_ARW	HUMI_SL	PT_JP2	SEG_TSP14
14	HUMI_TD3			HUMI_FILTER		SEG_TSP15
15	HUMI_OH3			TEMP_LIMIT_H		SEG_TSP16
16	HUMI_OL3		TEMP_RET_KIND	TEMP_LIMIT_L		SEG_TSP17
17	HUMI_MR3		TEMP_RET_RL			SEG_TSP18
18	HUMI_PB4		TEMP_RET_RH			SEG_TSP19
19	HUMI_TI4					SEG_TSP20
20	HUMI_TD4				PT_SS3	SEG_TSP21
21	HUMI_OH4		HUMI_RET_KIND		PT_ES3	SEG_TSP22
22	HUMI_OL4		HUMI_RET_RH		PT_RPT3	SEG_TSP23
23	HUMI_MR4		HUMI_RET_RL		PT_JP3	SEG_TSP24
24	HUMI_PB5					SEG_TSP25
25	HUMI_TI5					SEG_TSP26
26	HUMI_TD5					SEG_TSP27
27	HUMI_OH5					SEG_TSP28
28	HUMI_OL5					SEG_TSP29
29	HUMI_MR5					SEG_TSP30
30	HUMI_PB6				PT_SS4	SEG_TSP31
31	HUMI_TI6				PT_ES4	SEG_TSP32
32	HUMI_TD6				PT_RPT4	SEG_TSP33
33	HUMI_OH6				PT_JP4	SEG_TSP34

NO	HUMI_PID	COMM	OUTPUT	INPUT	PROGRAM	PROG_INFO1
	600	700	800	900	1000	1100
34	HUMI_OL6					SEG_TSP35
35	HUMI_MR6					SEG_TSP36
36						SEG_TSP37
37						SEG_TSP38
38						SEG_TSP39
39			COCON_IS1			SEG_TSP40
40			COCON_IS2	DP_RL	PT_SS5	SEG_TSP41
41			COCON_IS3	DP_P1	PT_ES5	SEGT_TSP42
42			COCON_IS4	DP_P2	PT_RPT5	SEG_TSP43
43			COCON_IS5	DP_RH	PT_JP5	SEG_TSP44
44			COCON_IS6	DD_RL		SEG_TSP45
45			COCON_TS1	DD_P1		SEG_TSP46
46			COCON_TS2	DD_P2		SEG_TSP47
47			COCON_TS3	DD_RH		SEG_TSP48
48			COCON_AL1			SEG_TSP49
49			COCON_AL2			SEG_TSP50
50			COCON_AL3	WP_RL	PT_SS6	SEG_TSP51
51			COCON_AL4	WP_P1	PT_ES6	SEG_TSP52
52			COCON_TRUN	WP_P2	PT_RPT6	SEG_TSP53
53			COCON_HRUN	WP_RH	PT_JP6	SEG_TSP54
54			COCON_T1	WD_RL		SEG_TSP55
55			COCON_T2	WD_P1		SEG_TSP56
56			COCON_T3	WD_P2		SEG_TSP57
57			COCON_T4	WD_RH		SEG_TSP58
58			COCON_H1			SEG_TSP59
59			COCON_T1TM			SEG_TSP60
60			COCON_T2TM	RP_RL	PT_SS7	SEG_TSP61
61			COCON_T3TM	RP_P1	PT_ES7	SEG_TSP62
62			COCON_T4TM	RP_P2	PT_RPT7	SEG_TSP63
63			COCON_H1TM	RP_RH	PT_JP7	SEG_TSP64
64			COCON_TUP	RD_RL		SEG_TSP65
65			COCON_TSK	RD_P1		SEG_TSP66
66			COCON_TDN	RD_P2		SEG_TSP67
67			COCON_TUP_P	RD_RH		SEG_TSP68
68			COCON_TSK_P			SEG_TSP69

NO	HUMI_PID	COMM	OUTPUT	INPUT	PROGRAM	PROG_INFO1
	600	700	800	900	1000	1100
69			DOCON_TDN_P			SEG_TSP70
70			DOCON_HUP		PT_SS8	SEG_TSP71
71			DOCON_HSK		PT_ES8	SEG_TSP72
72			DOCON_HDN		PT_RPT8	SEG_TSP73
73			DOCON_HUP_P		PT_JP8	SEG_TSP74
74			DOCON_HSK_P			SEG_TSP75
75			DOCON_HDN_P			SEG_TSP76
76			DOCON_DRAIN			SEG_TSP77
77			DOCON_ERR			SEG_TSP78
78			DOCON_PTEND			SEG_TSP79
79			DOCON_1REF			SEG_TSP80
80			DOCON_2REF		PT_SS9	SEG_TSP81
81			DOCON_DRAIN_P		PT_ES9	SEG_TSP82
82			DOCON_ERR_P		PT_RPT9	SEG_TSP83
83			DOCON_PTEND_P		PT_JP9	SEG_TSP84
84			DOCON_1REF_P			SEG_TSP85
85			DOCON_2REF_P			SEG_TSP86
86						SEG_TSP87
87						SEG_TSP88
88						SEG_TSP89
89						SEG_TSP90
90					PT_SS10	SEG_TSP91
91					PT_ES10	SEG_TSP92
92					PT_RPT10	SEG_TSP93
93					PT_JP10	SEG_TSP94
94						SEG_TSP95
95						SEG_TSP96
96						SEG_TSP97
97						SEG_TSP98
98						SEG_TSP99
99						SEG_TSP100

## D-Register 1200~1799

NO	PROG_INFO2	PROG_INFO3	PROG_INFO4	PROG_INFO5	PROG_INFO6	ON/OFF
	1200	1300	1400	1500	1600	1700
0	SEG_HSP1	SEG_TM1	SEG_TS11	SEG_TS21	SEG_WT1	ONF_LOWSP_T1
1	SEG_HSP2	SEG_TM2	SEG_TS12	SEG_TS22	SEG_WT2	ONF_MIDSP_T1
2	SEG_HSP3	SEG_TM3	SEG_TS13	SEG_TS23	SEG_WT3	ONF_HIGHSP_T1
3	SEG_HSP4	SEG_TM4	SEG_TS14	SEG_TS24	SEG_WT4	ONF_DIFH_T1
4	SEG_HSP5	SEG_TM5	SEG_TS15	SEG_TS25	SEG_WT5	ONF_DIFL_T1
5	SEG_HSP6	SEG_TM6	SEG_TS16	SEG_TS26	SEG_WT6	
6	SEG_HSP7	SEG_TM7	SEG_TS17	SEG_TS27	SEG_WT7	
7	SEG_HSP8	SEG_TM8	SEG_TS18	SEG_TS28	SEG_WT8	
8	SEG_HSP9	SEG_TM9	SEG_TS19	SEG_TS29	SEG_WT9	
9	SEG_HSP10	SEG_TM10	SEG_TS110	SEG_TS210	SEG_WT10	
10	SEG_HSP11	SEG_TM11	SEG_TS111	SEG_TS211	SEG_WT11	ONF_LOWSP_T2
11	SEG_HSP12	SEG_TM12	SEG_TS112	SEG_TS212	SEG_WT12	ONF_MIDSP_T2
12	SEG_HSP13	SEG_TM13	SEG_TS113	SEG_TS213	SEG_WT13	ONF_HIGHSP_T2
13	SEG_HSP14	SEG_TM14	SEG_TS114	SEG_TS214	SEG_WT14	ONF_DIFH_T2
14	SEG_HSP15	SEG_TM15	SEG_TS115	SEG_TS215	SEG_WT15	ONF_DIFL_T2
15	SEG_HSP16	SEG_TM16	SEG_TS116	SEG_TS216	SEG_WT16	
16	SEG_HSP17	SEG_TM17	SEG_TS117	SEG_TS217	SEG_WT17	
17	SEG_HSP18	SEG_TM18	SEG_TS118	SEG_TS218	SEG_WT18	
18	SEG_HSP19	SEG_TM19	SEG_TS119	SEG_TS219	SEG_WT19	
19	SEG_HSP20	SEG_TM20	SEG_TS120	SEG_TS220	SEG_WT20	
20	SEG_HSP21	SEG_TM21	SEG_TS121	SEG_TS221	SEG_WT21	ONF_LOWSP_T3
21	SEG_HSP22	SEG_TM22	SEG_TS122	SEG_TS222	SEG_WT22	ONF_MIDSP_T3
22	SEG_HSP23	SEG_TM23	SEG_TS123	SEG_TS223	SEG_WT23	ONF_HIGHSP_T3
23	SEG_HSP24	SEG_TM24	SEG_TS124	SEG_TS224	SEG_WT24	ONF_DIFH_T3
24	SEG_HSP25	SEG_TM25	SEG_TS125	SEG_TS225	SEG_WT25	ONF_DIFL_T3
25	SEG_HSP26	SEG_TM26	SEG_TS126	SEG_TS226	SEG_WT26	
26	SEG_HSP27	SEG_TM27	SEG_TS127	SEG_TS227	SEG_WT27	
27	SEG_HSP28	SEG_TM28	SEG_TS128	SEG_TS228	SEG_WT28	
28	SEG_HSP29	SEG_TM29	SEG_TS129	SEG_TS229	SEG_WT29	
29	SEG_HSP30	SEG_TM30	SEG_TS130	SEG_TS230	SEG_WT30	
30	SEG_HSP31	SEG_TM31	SEG_TS131	SEG_TS231	SEG_WT31	ONF_LOWSP_H1
31	SEG_HSP32	SEG_TM32	SEG_TS132	SEG_TS232	SEG_WT32	ONF_MIDSP_H1
32	SEG_HSP33	SEG_TM33	SEG_TS133	SEG_TS233	SEG_WT33	ONF_HIGHSP_H1
33	SEG_HSP34	SEG_TM34	SEG_TS134	SEG_TS234	SEG_WT34	ONF_DIFH_H1

NO	PROG_INFO2	PROG_INFO3	PROG_INFO4	PROG_INFO5	PROG_INFO6	
	1200	1300	1400	1500	1600	1700
34	SEG_HSP35	SEG_TM35	SEG_TS135	SEG_TS235	SEG_WT35	ONF_DIFL_H1
35	SEG_HSP36	SEG_TM36	SEG_TS136	SEG_TS236	SEG_WT36	
36	SEG_HSP37	SEG_TM37	SEG_TS137	SEG_TS237	SEG_WT37	
37	SEG_HSP38	SEG_TM38	SEG_TS138	SEG_TS238	SEG_WT38	
38	SEG_HSP39	SEG_TM39	SEG_TS139	SEG_TS239	SEG_WT39	
39	SEG_HSP40	SEG_TM40	SEG_TS140	SEG_TS240	SEG_WT40	
40	SEG_HSP41	SEG_TM41	SEG_TS141	SEG_TS241	SEG_WT41	
41	SEG_HSP42	SEG_TM42	SEG_TS142	SEG_TS242	SEG_WT42	
42	SEG_HSP43	SEG_TM43	SEG_TS143	SEG_TS243	SEG_WT43	
43	SEG_HSP44	SEG_TM44	SEG_TS144	SEG_TS244	SEG_WT44	
44	SEG_HSP45	SEG_TM45	SEG_TS145	SEG_TS245	SEG_WT45	
45	SEG_HSP46	SEG_TM46	SEG_TS146	SEG_TS246	SEG_WT46	
46	SEG_HSP47	SEG_TM47	SEG_TS147	SEG_TS247	SEG_WT47	
47	SEG_HSP48	SEG_TM48	SEG_TS148	SEG_TS248	SEG_WT48	
48	SEG_HSP49	SEG_TM49	SEG_TS149	SEG_TS249	SEG_WT49	
49	SEG_HSP50	SEG_TM50	SEG_TS150	SEG_TS250	SEG_WT50	
50	SEG_HSP51	SEG_TM51	SEG_TS151	SEG_TS251	SEG_WT51	
51	SEG_HSP52	SEG_TM52	SEG_TS152	SEG_TS252	SEG_WT52	
52	SEG_HSP53	SEG_TM53	SEG_TS153	SEG_TS253	SEG_WT53	
53	SEG_HSP54	SEG_TM54	SEG_TS154	SEG_TS254	SEG_WT54	
54	SEG_HSP55	SEG_TM55	SEG_TS155	SEG_TS255	SEG_WT55	
55	SEG_HSP56	SEG_TM56	SEG_TS156	SEG_TS256	SEG_WT56	
56	SEG_HSP57	SEG_TM57	SEG_TS157	SEG_TS257	SEG_WT57	
57	SEG_HSP58	SEG_TM58	SEG_TS158	SEG_TS258	SEG_WT58	
58	SEG_HSP59	SEG_TM59	SEG_TS159	SEG_TS259	SEG_WT59	
59	SEG_HSP60	SEG_TM60	SEG_TS160	SEG_TS260	SEG_WT60	
60	SEG_HSP61	SEG_TM61	SEG_TS161	SEG_TS261	SEG_WT61	
61	SEG_HSP62	SEG_TM62	SEG_TS162	SEG_TS262	SEG_WT62	
62	SEG_HSP63	SEG_TM63	SEG_TS163	SEG_TS263	SEG_WT63	
63	SEG_HSP64	SEG_TM64	SEG_TS164	SEG_TS264	SEG_WT64	
64	SEG_HSP65	SEG_TM65	SEG_TS165	SEG_TS265	SEG_WT65	
65	SEG_HSP66	SEG_TM66	SEG_TS166	SEG_TS266	SEG_WT66	
66	SEG_HSP67	SEG_TM67	SEG_TS167	SEG_TS267	SEG_WT67	
67	SEG_HSP68	SEG_TM68	SEG_TS168	SEG_TS268	SEG_WT68	
68	SEG_HSP69	SEG_TM69	SEG_TS169	SEG_TS269	SEG_WT69	

NO	PROG_INFO2	PROG_INFO3	PROG_INFO4	PROG_INFO5	PROG_INFO6	
	1200	1300	1400	1500	1600	1700
69	SEG_HSP70	SEG_TM70	SEG_TS170	SEG_TS270	SEG_WT70	
70	SEG_HSP71	SEG_TM71	SEG_TS171	SEG_TS271	SEG_WT71	
71	SEG_HSP72	SEG_TM72	SEG_TS172	SEG_TS272	SEG_WT72	
72	SEG_HSP73	SEG_TM73	SEG_TS173	SEG_TS273	SEG_WT73	
73	SEG_HSP74	SEG_TM74	SEG_TS174	SEG_TS274	SEG_WT74	
74	SEG_HSP75	SEG_TM75	SEG_TS175	SEG_TS275	SEG_WT75	
75	SEG_HSP76	SEG_TM76	SEG_TS176	SEG_TS276	SEG_WT76	
76	SEG_HSP77	SEG_TM77	SEG_TS177	SEG_TS277	SEG_WT77	
77	SEG_HSP78	SEG_TM78	SEG_TS178	SEG_TS278	SEG_WT78	
78	SEG_HSP79	SEG_TM79	SEG_TS179	SEG_TS279	SEG_WT79	
79	SEG_HSP80	SEG_TM80	SEG_TS180	SEG_TS280	SEG_WT80	
80	SEG_HSP81	SEG_TM81	SEG_TS181	SEG_TS281	SEG_WT81	
81	SEG_HSP82	SEG_TM82	SEG_TS182	SEG_TS282	SEG_WT82	
82	SEG_HSP83	SEG_TM83	SEG_TS183	SEG_TS283	SEG_WT83	
83	SEG_HSP84	SEG_TM84	SEG_TS184	SEG_TS284	SEG_WT84	
84	SEG_HSP85	SEG_TM85	SEG_TS185	SEG_TS285	SEG_WT85	
85	SEG_HSP86	SEG_TM86	SEG_TS186	SEG_TS286	SEG_WT86	
86	SEG_HSP87	SEG_TM87	SEG_TS187	SEG_TS287	SEG_WT87	
87	SEG_HSP88	SEG_TM88	SEG_TS188	SEG_TS288	SEG_WT88	
88	SEG_HSP89	SEG_TM89	SEG_TS189	SEG_TS289	SEG_WT89	
89	SEG_HSP90	SEG_TM90	SEG_TS190	SEG_TS290	SEG_WT90	
90	SEG_HSP91	SEG_TM91	SEG_TS191	SEG_TS291	SEG_WT91	
91	SEG_HSP92	SEG_TM92	SEG_TS192	SEG_TS292	SEG_WT92	
92	SEG_HSP93	SEG_TM93	SEG_TS193	SEG_TS293	SEG_WT93	
93	SEG_HSP94	SEG_TM94	SEG_TS194	SEG_TS294	SEG_WT94	
94	SEG_HSP95	SEG_TM95	SEG_TS195	SEG_TS295	SEG_WT95	
95	SEG_HSP96	SEG_TM96	SEG_TS196	SEG_TS296	SEG_WT96	
96	SEG_HSP97	SEG_TM97	SEG_TS197	SEG_TS297	SEG_WT97	
97	SEG_HSP98	SEG_TM98	SEG_TS198	SEG_TS298	SEG_WT98	
98	SEG_HSP99	SEG_TM99	SEG_TS199	SEG_TS299	SEG_WT99	
99	SEG_HSP100	SEG_TM100	SEG_TS1100	SEG_TS2100	SEG_WT100	



---

SAMWONTECH CO., LTD.

202-703, Buchon Techno-park,  
Yakdae-dong, Wonmi-gu, Buchon,  
Gyeonggi-do, Korea 420-733  
TEL: +82-32-326-9120, 9121  
FAX: +82-32-326-9119  
[http:// www.samwontech.com](http://www.samwontech.com)  
E-mail: [webmaster@samwontech.com](mailto:webmaster@samwontech.com)

Further information contact Samwontech