



- Bar display of product pass line
- Operates by signal comparison
- Hot scale in Field of View ignored
- Dirty lens & steam has no effect
- No motor driven rotating mirror
- 1 - 250 mSec. response time, adjustable
- Continuous & remote self-test
- Relay and Opto-isolated outputs
- NPN / PNP Switch Selectable Transistor Output (with 24 VDC connection only)
- 110 VAC & 24 VDC connection in one unit
- Robust IP66 aluminum housing with unique combined air purge & cooling facility

## General Description

The Pathfinder Scanner utilizes the latest microprocessor technology to ensure precise reliable detection.

Whereas old style HMD's purely detect the hot product above pre-set thresholds, the PATHFINDER Scanner operates by microprocessor comparison of the background and hot product signal. Neither static hot scale or steam in the field of view causes false triggering. Furthermore, lens contamination will not raise its trip level.

While static analog HMD's utilize single diode detection and Rotary Scanners incorporate rotating mirrors, the Pathfinder Scanner utilizes a digitally scanned Germanium Diode Array. This new technology removes the maintenance associated with Rotary Scanners yet provides the high reliability and accuracy associated with Scanners.

Microprocessor technology provides exceptionally fast and accurate detection of Rod or Strip leading/trailing edge where wide variations of IR signal are present. Response times are digitally adjusted by locking timers. To assist in alignment, product path is duplicated by an LED Bar Display. Which is also used to indicate adjustments to precise values.

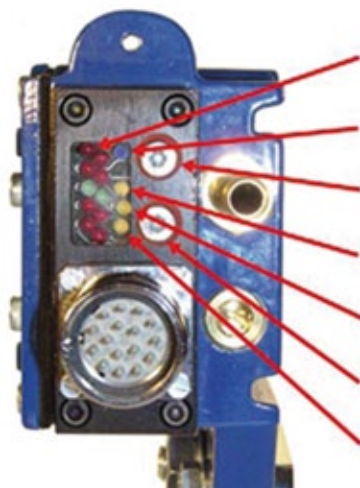

- Red LED's - Hot product and setting levels
- Green LED - Power On & fault
- Upper setting switch
- Yellow LED - Delay time
- Yellow LED - Control margin set
- Lower setting switch
- Yellow LED - Amplification

## Rear Bar Display

Red LED's indicate location of hot product Scanner is in Operating mode or pre-set levels when in Adjustment mode.

Yellow LED's are on in self - test mode. Top and bottom yellow LED's mimic outputs - except when adjusting a setting or when in self - test mode.



## Housing Specifications

Housing: Aluminum AL6, Oven baked blue paint  
 Housing Rating: IEC IP66, DIN, 89011  
 Weight w/o Cable: 1.9 Kg  
 Connector: IP65 Plug/Socket  
 Cable Length: 1.5 M Standard up 10 M available  
 Cooling: Air Cooled & Air Purged /  
 Water Cooled & Air Purged

## Air & Water Specification

Air Pressure: 1 cu ft./min at 5 PSI for normal conditions  
 5 cu ft./min at 15 PSI for severe conditions  
 Water Pressure: 5 to 10 PSI, 40 PSI Maximum  
 Water Volume: Regulate between 0.2 - 0.3 liters/min.  
 Water Temp.: For Ambient Temperature up to 70°C use ambient water below 20°C  
 For Ambient Temperature up to 80°C use water chilled to 5°C

## Dimensions

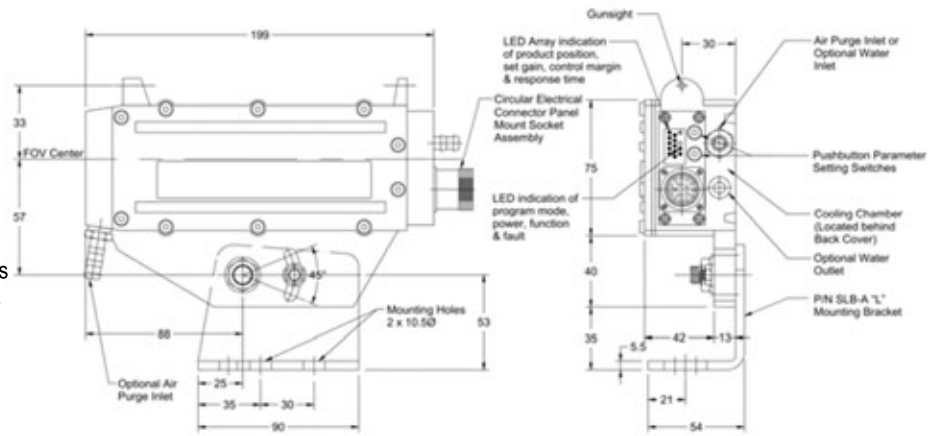

## General Specification

Typical Detection	10mm Rod at 350°C from 2 meters and 50mm Bar at 350°C from 4 meters.	Supply Voltage	110 VAC $\pm$ 15% 50/60 Hz and 24 VDC +10%, -15%
Sensing Elements	Electronically Scanned Germanium Diodes	Power Consumption	5 VA
Scan Rate	1,200 Scans/Sec.	Operating Temperature	-10°C to +50°C without air cooling, to 60°C with air cooling & to 70°C with water cooling
Min Product Temp.	300°C	Remote Self Check	Remotely Energized - Continuous Test
Product Position Display	10 LED Bar Display	Continuous Self Check	Opto-isolated Outputs (+) & (-)
Scanning Angle:	Standard: 1° x 15° Optional: 2° x 22°, 3° x 35°;	Output (1)	Reed Relay Output (N/O) 240 VAC, 1A, 20W - 4 msec. response
Detection Technique	Differential comparison between background and hot product.	Output (2)	Opto-isolated Output 300 V, 150 mA, 20mW - 2 msec. response
Response Time:	1- 250 msec. digitally adjustable locking timers	Output (3)	NPN & PNP Outputs 400 mA, 45 V, 2A peak

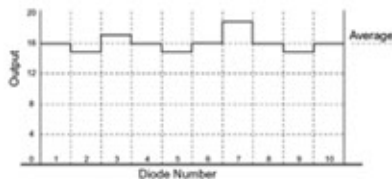

Background IR Signal

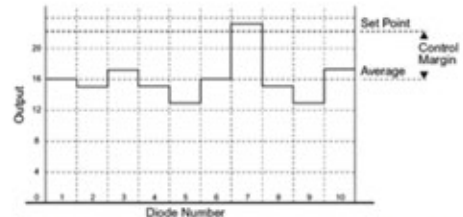
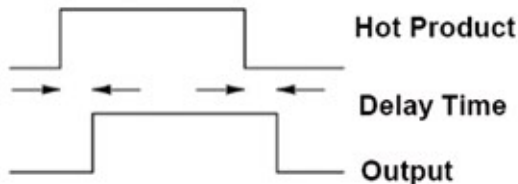

Chart illustrating signal from passing hot product

### Chart illustrating signal from typical hot background

The hot product is detected by reference to an appropriate site-adjusted control margin (stored in Non-Volatile memory) that ensures sufficient gap between background IR signal and the IR radiating from the product.

This chart illustrates the control margin. Where the background IR is uniform then the control margin can be set to a lower figure. Any hot product passing needs to give a signal that exceeds the set point.



### Delay Timer Function

Outputs delayed from the detection of leading and trailing edge by 10 digitally adjustable preset delay times from 1msec. to 250msec.

## Moduloc System Engineering Ltd. & Co.



Kexin Building No. 212, Changjiang Road, Yantai Development Zone,  
 Yantai, Shandong, China P. R.  
 phone: +86-535-2161058  
 e-mail: info@mse-intl.com

Zip code: 264006  
 fax: +86-535-2161090  
 web: www.mse-intl.com

