



大井

自動加壓系統

ISO 9001

IC 系列 電腦變頻恆壓泵浦
變頻恆壓交互並列泵浦
X 系列 壓差式自動加壓泵浦
壓差式交互並列泵浦



大井泵浦工業股份有限公司

綜合說明	頁次
產品用途	3
適用液體	3
使用條件	3
產品說明	3
型式說明	3
訂購說明	3
安裝注意	3

IC 系列 電腦變頻恆壓泵浦	頁次
特性曲線 - 單台	4
特性曲線 - 交互並列	4
規格表 - 單台	5
規格表 - 交互並列	7
外型尺寸 - 單台 2T / 4T / 8T / 12T	9
外型尺寸 - 單台 25T / 50T	10
外型尺寸 - 交互並列	11

X 系列 壓差式自動加壓機	頁次
特性曲線 - 單台	12
特性曲線 - 交互並列	12
規格表 - 單台	13
規格表 - 交互並列	15
外型尺寸 - 單台 2T / 4T	17
外型尺寸 - 單台 8T / 12T / 25T / 50T	18
外型尺寸 - 交互並列	19

產品用途

公寓、住宅、別墅給水、工廠供水、供水系統、飲水系統、RO水處理、超級市場、汽車旅館、SPA。

適用液體

不含雜質之清水、乾淨稀薄非腐蝕性之中性液體

使用條件

環境溫度：Max. +40°C

液體溫度：+2°C~+40°C

入口壓力：

IC系列：須小於恆壓設定值

X系列：須小於壓力開關(ON)設定值

產品說明

IC系列：

用水時馬達平緩啟動，變頻器依壓力感應器回饋感測用水壓力，進而控制馬達運轉頻率，無段改變馬達轉速，使用水壓力穩定維持在壓力設定值。

恆壓穩壓

使用時壓力均不會高於壓力設定值，用水量超過恆壓範圍仍保持穩壓供水。

無水斷電

水源無水時泵浦會自動斷電，並自行嚐試啟動，直至正常供水為止。

止水停機

停止用水時，微電腦自動偵測回傳並控制馬達減速停機。

測漏補償

管路洩漏、滴水，微電腦自動偵測並連轉泵浦補償壓力至設定值。

壓差切換

遇壓力傳送器功能異常時，可切換至壓差功能，避免無水可用。(TPH 2T/4T—IC 標準型無此項功能)

X系列：

使用水時，管壓降至壓力開關ON值時，泵浦自行啟動增壓送水；停止用水時，管壓達壓力開關OFF值時，泵浦自動關機。

交互並列系列：

並列運轉：使用時單台啟動，隨使用水量增加，單台運轉無法滿足設定之壓力及使用水量時，第二台自行啟動併入運轉補償，隨水量遞減，單台可以滿足設定之壓力及使用水量時，第二台自動停機，

交互運轉：啟動順序可依設定之時間交替運轉。

型式說明

範例

泵系列TPH

額定流量[m³/h]

額定揚程[kg/cm²]

不銹鋼系列

IC: 電腦變頻系列

X: 壓差式系列

豪華型

交互並列台數

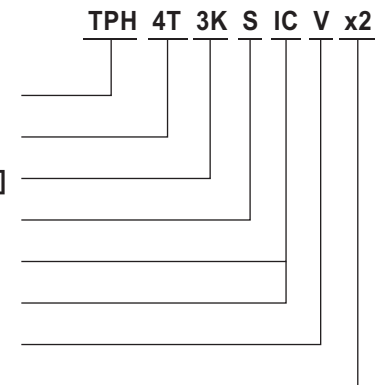

訂購說明

1. 各機種可指定出入口徑。
2. 可指定出入口為法蘭式。
3. 交互並列系列可指定入口為合流管。
4. 可指定壓力桶容量及材質。
5. 一般配置之壓力桶以烤漆壓力桶為主，不銹鋼壓力桶須另外指定。
6. 可指定於出口管路中添加考克。
7. 100HP以下馬力機種可接受定製。
8. 壓差式機種可接受50Hz定製。
9. IC系列可指定變頻器馬力。
10. 以上指定，價格另報。

安裝注意

- 出口管路請使用金屬管，可防止管壓過高或液體溫度異常，導致管路破裂。
- 入口管路勿加裝透氣管，以防止泵浦吸入空氣，導致泵浦動作異常。
- 須防止蓄水桶入水時水面所產生之氣泡被泵浦吸入，導致泵浦動作異常。

馬達

保護等級: IP54

絕緣等級: F.

特性曲線 - 單台

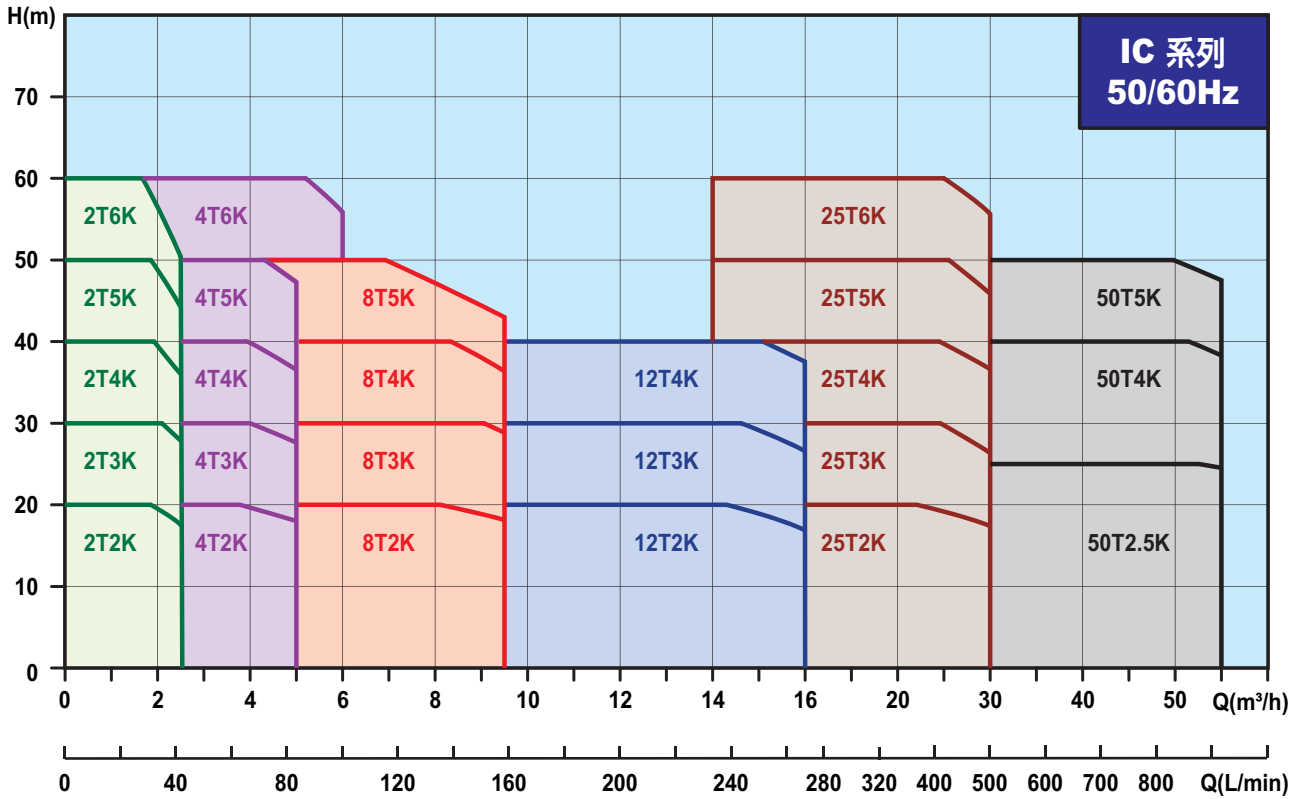

特性曲線 - 雙台交互並列

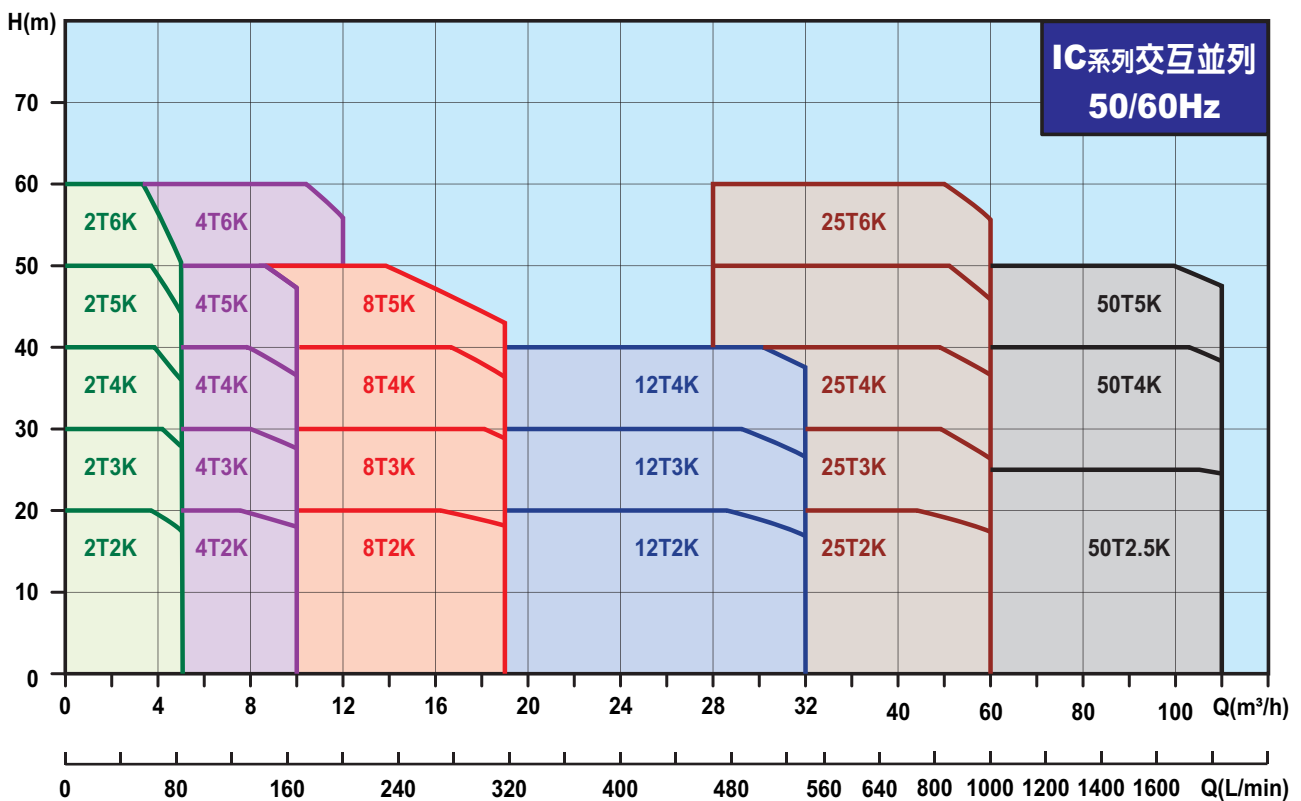

規格表 - 單台 (50/60Hz)

編號	型式	變頻器馬力 (HP)	電壓 (V)	恆壓設定值 (kg/cm ²)	入口徑 (in.)	出口徑 (in.)	額定揚程 (M)	額定水量 (L/min)
A001	TPH2T2KIC	½	1Ø 220V / 3Ø 220V	2.0	1	1	20	35
A002			3Ø 380V					
A003	TPH2T2KSIC		1Ø 220V / 3Ø 220V					
A004			3Ø 380V					
A005	TPH2T3KIC	1	1Ø 220V / 3Ø 220V	3.0	1	1	30	35
A006			3Ø 380V					
A007	TPH2T3KSIC		1Ø 220V / 3Ø 220V					
A008			3Ø 380V					
A009	TPH2T4KIC	1	1Ø 220V / 3Ø 220V	4.0	1	1	40	35
A010			3Ø 380V					
A011	TPH2T4KSIC		1Ø 220V / 3Ø 220V					
A012			3Ø 380V					
A013	TPH2T5KIC	1	1Ø 220V / 3Ø 220V	5.0	1	1	50	35
A014			3Ø 380V					
A015	TPH2T5KSIC		1Ø 220V / 3Ø 220V					
A016			3Ø 380V					
A017	TPH2T6KIC	1	1Ø 220V / 3Ø 220V	6.0	1	1	60	35
A018			3Ø 380V					
A019	TPH2T6KSIC		1Ø 220V / 3Ø 220V					
A020			3Ø 380V					
A021	TPH4T2KIC	1	1Ø 220V / 3Ø 220V	2.0	1½	1½	20	70
A022			3Ø 380V					
A023	TPH4T2KSIC		1Ø 220V / 3Ø 220V					
A024			3Ø 380V					
A025	TPH4T3KIC	1	1Ø 220V / 3Ø 220V	3.0	1½	1½	30	70
A026			3Ø 380V					
A027	TPH4T3KSIC		1Ø 220V / 3Ø 220V					
A028			3Ø 380V					
A029	TPH4T4KIC	2	1Ø 220V / 3Ø 220V	4.0	1½	1½	40	70
A030			3Ø 380V					
A031	TPH4T4KSIC		1Ø 220V / 3Ø 220V					
A032			3Ø 380V					
A033	TPH4T5KIC	2	1Ø 220V / 3Ø 220V	5.0	1½	1½	50	70
A034			3Ø 380V					
A035	TPH4T5KSIC		1Ø 220V / 3Ø 220V					
A036			3Ø 380V					
A037	TPH4T6KIC	2	1Ø 220V / 3Ø 220V	6.0	1½	1½	60	70
A038			3Ø 380V					
A039	TPH4T6KSIC		1Ø 220V / 3Ø 220V					
A040			3Ø 380V					
A041	TPH 8T2KIC	1	1Ø 220V / 3Ø 220V	2.0	2	2	20	135
A042			3Ø 380V					
A043	TPH8T2KSIC		1Ø 220V / 3Ø 220V					
A044			3Ø 380V					
A045	TPH8T3KIC	2	1Ø 220V / 3Ø 220V	3.0	2	2	30	135
A046			3Ø 380V					
A047	TPH8T3KSIC		1Ø 220V / 3Ø 220V					
A048			3Ø 380V					
A049	TPH8T4KIC	3	1Ø 220V / 3Ø 220V	4.0	2	2	40	135
A050			3Ø 380V					
A051	TPH8T4KSIC		1Ø 220V / 3Ø 220V					
A052			3Ø 380V					
A053	TPH8T5KIC	5	1Ø 220V / 3Ø 220V	5.0	2	2	50	115
A054			3Ø 380V					
A055	TPH8T5KSIC		1Ø 220V / 3Ø 220V					
A056			3Ø 380V					

規格表 - 單台 (50/60Hz)

編號	型式	變頻器 馬力 (HP)	電 壓 (V)	恆 壓 設定值 (kg/cm ²)	入口徑 (in.)	出口徑 (in.)	額定揚程 (M)	額定水量 (L/min)
A057	TPH12T2KIC	2	1Ø 220V / 3Ø 220V	2.0	2	2	20	200
A058			3Ø 380V					
A059	TPH12T2KSIC		1Ø 220V / 3Ø 220V					
A060			3Ø 380V					
A061	TPH12T3KIC	3	1Ø 220V / 3Ø 220V	3.0	2	2	30	200
A062			3Ø 380V					
A063	TPH12T3KSIC		1Ø 220V / 3Ø 220V					
A064			3Ø 380V					
A065	TPH12T4KIC	5	1Ø 220V / 3Ø 220V	4.0	2	2	40	200
A066			3Ø 380V					
A067	TPH12T4KSIC		1Ø 220V / 3Ø 220V					
A068			3Ø 380V					
A069	TPH25T2KIC	5	3Ø 220V	2.0	3	3	20	415
A070			3Ø 380V					
A071	TPH25T2KSIC		3Ø 220V					
A072			3Ø 380V					
A073	TPH25T3KIC	5	3Ø 220V	3.0	3	3	30	415
A074			3Ø 380V					
A075	TPH25T3KSIC		3Ø 220V					
A076			3Ø 380V					
A077	TPH25T4KIC	7½	3Ø 220V	4.0	3	3	40	415
A078			3Ø 380V					
A079	TPH25T4KSIC		3Ø 220V					
A080			3Ø 380V					
A081	TPH25T5KIC	10	3Ø 220V	5.0	3	3	50	415
A082			3Ø 380V					
A083	TPH25T5KSIC		3Ø 220V					
A084			3Ø 380V					
A085	TPH25T6KIC	10	3Ø 220V	6.0	3	3	60	415
A086			3Ø 380V					
A087	TPH25T6KSIC		3Ø 220V					
A088			3Ø 380V					
A089	TPH50T2.5KIC	7½	3Ø 220V	2.5	4	4	25	830
A090			3Ø 380V					
A091	TPH50T2.5KSIC		3Ø 220V					
A092			3Ø 380V					
A093	TPH50T4KIC	10	3Ø 220V	4.0	4	4	40	830
A094			3Ø 380V					
A095	TPH50T4KSIC		3Ø 220V					
A096			3Ø 380V					
A097	TPH50T5KIC	15	3Ø 220V	5.0	4	4	50	830
A098			3Ø 380V					
A099	TPH50T5KSIC		3Ø 220V					
A100			3Ø 380V					

規格表 - 交互並列 (50/60Hz)

編號	型式	變頻器馬力 (HP)	電壓 (V)	恆壓設定值 (kg/cm ²)	入口徑 (in.)	出口徑 (in.)	額定揚程 (M)	額定水量 (L/min)
B001	TPH2T2KIC x2	½ x2台	1Ø 220V / 3Ø 220V	2.0	1	1½	20	70
B002			3Ø 380V					
B003	1Ø 220V / 3Ø 220V							
B004	3Ø 380V							
B005	TPH2T3KIC x2	1 x2台	1Ø 220V / 3Ø 220V	3.0	1	1½	30	70
B006			3Ø 380V					
B007	1Ø 220V / 3Ø 220V							
B008	3Ø 380V							
B009	TPH2T4KIC x2	1 x2台	1Ø 220V / 3Ø 220V	4.0	1	1½	40	70
B010			3Ø 380V					
B011	1Ø 220V / 3Ø 220V							
B012	3Ø 380V							
B013	TPH2T5KIC x2	1 x2台	1Ø 220V / 3Ø 220V	5.0	1	1½	50	70
B014			3Ø 380V					
B015	1Ø 220V / 3Ø 220V							
B016	3Ø 380V							
B017	TPH2T6KIC x2	1 x2台	1Ø 220V / 3Ø 220V	6.0	1	1½	60	70
B018			3Ø 380V					
B019	1Ø 220V / 3Ø 220V							
B020	3Ø 380V							
B021	TPH4T2KIC x2	1 x2台	1Ø 220V / 3Ø 220V	2.0	1½	2	20	135
B022			3Ø 380V					
B023	1Ø 220V / 3Ø 220V							
B024	3Ø 380V							
B025	TPH4T3KIC x2	1 x2台	1Ø 220V / 3Ø 220V	3.0	1½	2	30	135
B026			3Ø 380V					
B027	1Ø 220V / 3Ø 220V							
B028	3Ø 380V							
B029	TPH4T4KIC x2	2 x2台	1Ø 220V / 3Ø 220V	4.0	1½	2	40	135
B030			3Ø 380V					
B031	1Ø 220V / 3Ø 220V							
B032	3Ø 380V							
B033	TPH4T5KIC x2	2 x2台	1Ø 220V / 3Ø 220V	5.0	1½	2	50	135
B034			3Ø 380V					
B035	1Ø 220V / 3Ø 220V							
B036	3Ø 380V							
B037	TPH4T6KIC x2	2 x2台	1Ø 220V / 3Ø 220V	6.0	1½	2	60	135
B038			3Ø 380V					
B039	1Ø 220V / 3Ø 220V							
B040	3Ø 380V							
B041	TPH 8T2KIC x2	1 x2台	1Ø 220V / 3Ø 220V	2.0	2	3	20	270
B042			3Ø 380V					
B043	1Ø 220V / 3Ø 220V							
B044	3Ø 380V							
B045	TPH8T3KIC x2	2 x2台	1Ø 220V / 3Ø 220V	3.0	2	3	30	270
B046			3Ø 380V					
B047	1Ø 220V / 3Ø 220V							
B048	3Ø 380V							
B049	TPH8T4KIC x2	3 x2台	1Ø 220V / 3Ø 220V	4.0	2	3	40	270
B050			3Ø 380V					
B051	1Ø 220V / 3Ø 220V							
B052	3Ø 380V							
B053	TPH8T5KIC x2	5 x2台	1Ø 220V / 3Ø 220V	5.0	2	3	50	230
B054			3Ø 380V					
B055	1Ø 220V / 3Ø 220V							
B056	3Ø 380V							

規格表 - 交互並列 (50/60Hz)

編號	型式	變頻器馬力 (HP)	電壓 (V)	恆壓設定值 (kg/cm ²)	入口徑 (in.)	出口徑 (in.)	額定揚程 (M)	額定水量 (L/min)
B057	TPH12T2KIC x2	2 x2台	1Ø 220V / 3Ø 220V	2.0	2	3	20	400
B058			3Ø 380V					
B059	1Ø 220V / 3Ø 220V							
B060	3Ø 380V							
B061	TPH12T3KIC x2	3 x2台	1Ø 220V / 3Ø 220V	3.0	2	3	30	400
B062			3Ø 380V					
B063	1Ø 220V / 3Ø 220V							
B064	3Ø 380V							
B065	TPH12T4KIC x2	5 x2台	1Ø 220V / 3Ø 220V	4.0	2	3	40	400
B066			3Ø 380V					
B067	1Ø 220V / 3Ø 220V							
B068	3Ø 380V							
B069	TPH25T2KIC x2	5 x2台	3Ø 220V	2.0	3	4	20	830
B070			3Ø 380V					
B071	TPH25T2KSIC x2		3Ø 220V					
B072			3Ø 380V					
B073	TPH25T3KIC x2	5 x2台	3Ø 220V	3.0	3	4	30	830
B074			3Ø 380V					
B075	TPH25T3KSIC x2		3Ø 220V					
B076			3Ø 380V					
B077	TPH25T4KIC x2	7½ x2台	3Ø 220V	4.0	3	4	40	830
B078			3Ø 380V					
B079	TPH25T4KSIC x2		3Ø 220V					
B080			3Ø 380V					
B081	TPH25T5KIC x2	10 x2台	3Ø 220V	5.0	3	4	50	830
B082			3Ø 380V					
B083	TPH25T5KSIC x2		3Ø 220V					
B084			3Ø 380V					
B085	TPH25T6KIC x2	10 x2台	3Ø 220V	6.0	3	4	60	830
B086			3Ø 380V					
B087	TPH25T6KSIC x2		3Ø 220V					
B088			3Ø 380V					
B089	TPH50T2.5KIC x2	7½ x2台	3Ø 220V	2.5	4	6	25	1660
B090			3Ø 380V					
B091	TPH50T2.5KSIC x2		3Ø 220V					
B092			3Ø 380V					
B093	TPH50T4KIC x2	10 x2台	3Ø 220V	4.0	4	6	40	1660
B094			3Ø 380V					
B095	TPH50T4KSIC x2		3Ø 220V					
B096			3Ø 380V					
B097	TPH50T5KIC x2	15 x2台	3Ø 220V	5.0	4	6	50	1660
B098			3Ø 380V					
B099	TPH50T5KSIC x2		3Ø 220V					
B100			3Ø 380V					

外型尺寸 2T/4T/8T/12T (mm)

● 圖1. TPH2T / 4T - IC

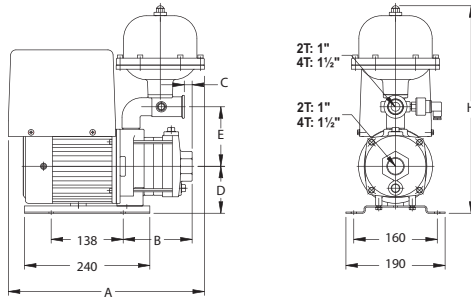

● 圖2. TPH2T - ICV

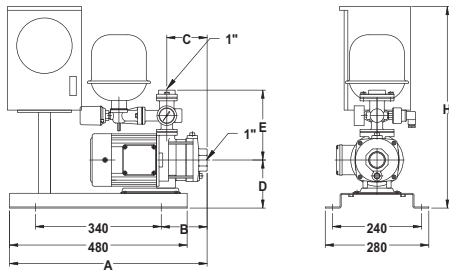

● 圖3. TPH4T2KICV / TPH4T3KICV

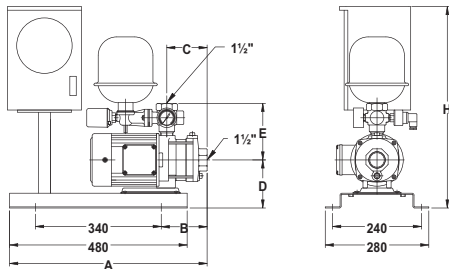

● 圖4. TPH4T4KICV ~ TPH4T6KICV

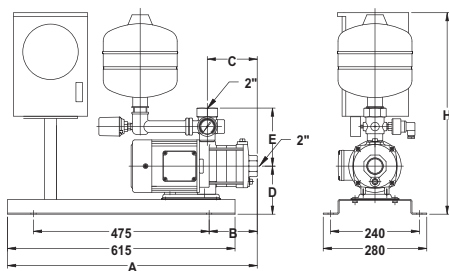

● 圖5. TPH8T / 12T - IC

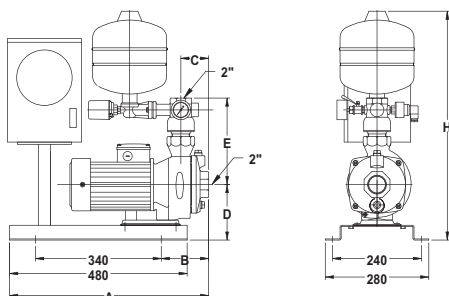

● 圖6. TPH 8T5KIC / TPH 12T4KIC (3Ø)

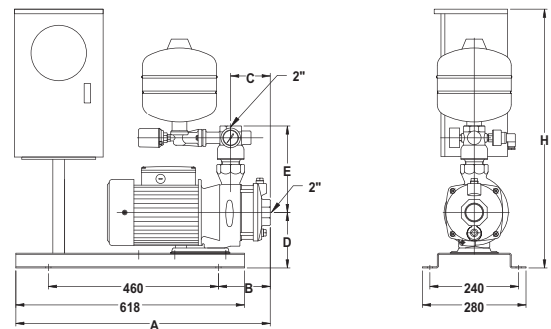

● 圖7. TPH 8T5KIC / TPH 12T4KIC (1Ø220V 5HP)

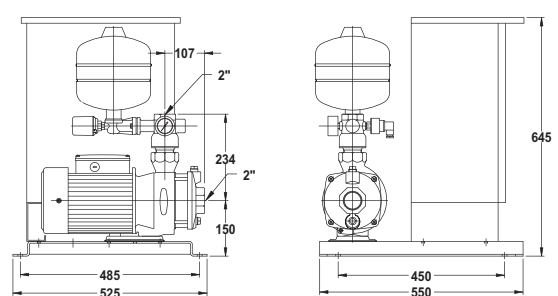

型式	A	B	C	D	E	H	壓力桶 (L)	例圖
TPH2T2KIC	376	114	-3	90	114	398	2	1
TPH2T3KIC	376	132	15	90	114	398	2	1
TPH2T4KIC	376	150	33	90	114	468	2	1
TPH2T5KIC	399	168	51	90	114	468	2	1
TPH2T6KIC	417	186	69	90	114	468	2	1
TPH2T2KICV	524	114	99	130	155	545	2.5	2
TPH2T3KICV	542	132	117	130	155	545	2.5	2
TPH2T4KICV	560	150	135	130	155	545	5	2
TPH2T5KICV	578	168	153	130	155	545	5	2
TPH2T6KICV	596	186	171	130	155	545	5	2
TPH4T2KIC	383	123	-2	90	125	415	2	1
TPH4T3KIC	394	150	26	90	125	415	2	1
TPH4T4KIC	408	177	53	90	125	485	2	1
TPH4T5KIC	435	204	80	90	125	485	2	1
TPH4T6KIC	462	231	107	90	125	485	2	1
TPH4T2KICV	533	123	108	130	155	545	2.5	3
TPH4T3KICV	560	150	135	130	155	545	2.5	3
TPH4T4KICV	702	157	162	130	155	545	5	4
TPH4T5KICV	729	184	189	130	155	545	5	4
TPH4T6KICV	753	211	216	130	155	545	5	4
TPH8T2KIC	538	128	75	150	235	620	5	5
TPH8T3KIC	570	160	107	150	235	620	5	5
TPH8T4KIC	570	160	107	150	235	620	5	5
TPH8T5KIC 3Ø	740	192	139	150	235	700	5	6
TPH12T2KIC	538	128	75	150	235	620	5	5
TPH12T3KIC	570	160	107	150	235	620	5	5
TPH12T4KIC 3Ø	708	160	107	150	235	700	5	6

外型尺寸 25T/ 50T (mm)

● 圖1. TPH 25T2KIC / TPH 25T3KIC

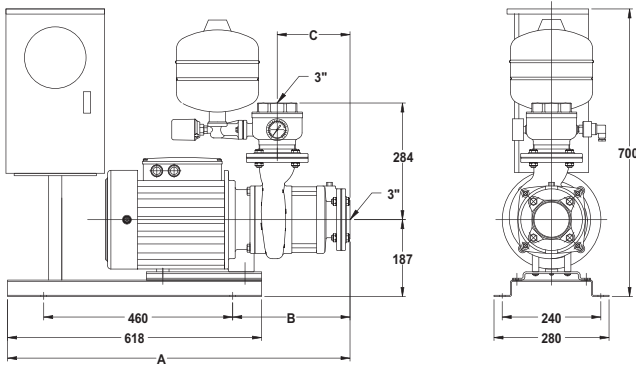

● 圖2. TPH 25T4KIC ~ TPH25T6KIC

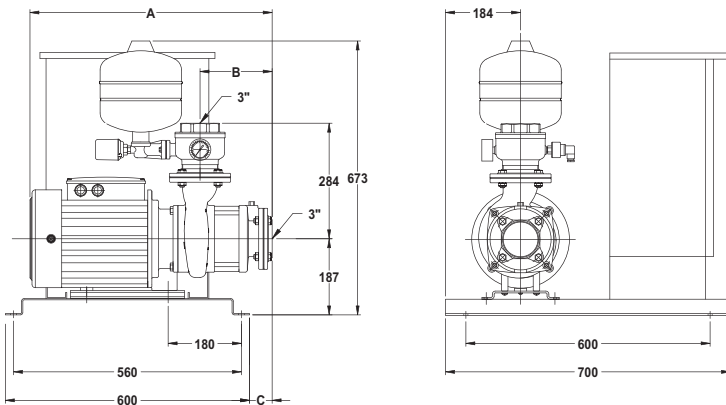

● 圖3. TPH 50T - IC

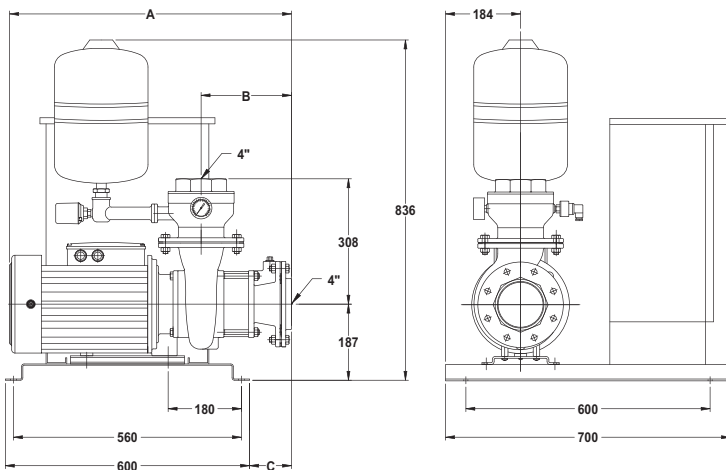

型式	A	B	C	壓力桶 (L)	例圖
TPH25T2KIC	776	228	120	5	1
TPH25T3KIC	836	288	180	5	1
TPH25T4KIC	598	108	58	5	2
TPH25T5KIC	708	240	118	5	2
TPH25T6KIC	708	240	118	5	2
TPH50T2.5KIC	583	162	43	12	3
TPH50T4KIC	693	222	103	12	3
TPH50T6KIC	743	222	103	12	3

外型尺寸 (mm)

● 圖1. TPH 2T / 4T – IC x2

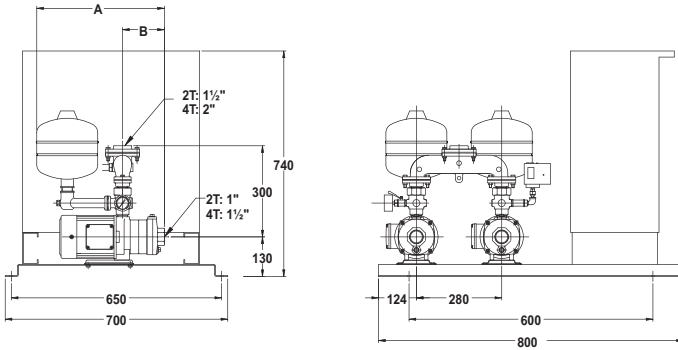

● 圖2. TPH 8T / 12T – IC x2

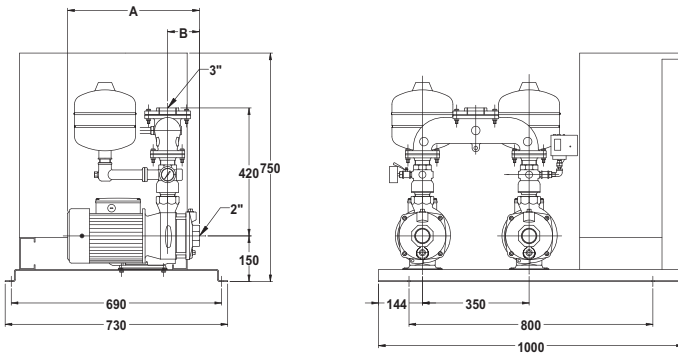

● 圖3. TPH 25T – IC x2

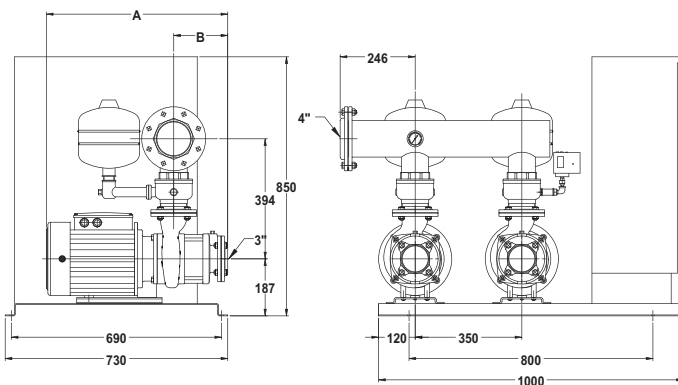

● 圖4. TPH 50T – IC x2

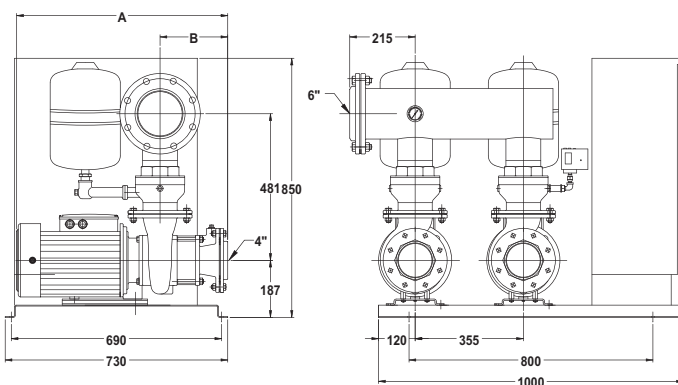

型式	A	B	壓力桶 (L)	例圖
TPH2T2KIC x2	395	99	2.5 x2	1
TPH2T3KIC x2	413	117	2.5 x2	1
TPH2T4KIC x2	431	135	5 x2	1
TPH2T5KIC x2	449	153	5 x2	1
TPH2T6KIC x2	467	171	5 x2	1
TPH4T2KIC x2	404	108	2.5 x2	1
TPH4T3KIC x2	431	135	2.5 x2	1
TPH4T4KIC x2	458	162	5 x2	1
TPH4T5KIC x2	485	189	5 x2	1
TPH4T6KIC x2	512	216	5 x2	1
TPH8T2KIC x2	395	75	12 x2	2
TPH8T3KIC x2	427	107	12 x2	2
TPH8T4KIC x2	435	107	12 x2	2
TPH8T5KIC x2	467	139	12 x2	2
TPH12T2KIC x2	395	75	12 x2	2
TPH12T3KIC x2	435	107	12 x2	2
TPH12T4KIC x2	435	107	12 x2	2
TPH25T2KIC x2	537.5	120	12 x2	3
TPH25T3KIC x2	597.5	180	12 x2	3
TPH25T4KIC x2	597.5	180	12 x2	3
TPH25T5KIC x2	707.5	240	12 x2	3
TPH25T6KIC x2	707.5	240	12 x2	3
TPH50T2.5KIC x2	583	162	12 x2	4
TPH50T4KIC x2	693	222	12 x2	4
TPH50T5KIC x2	743	222	12 x2	4

特性曲線 - 單台

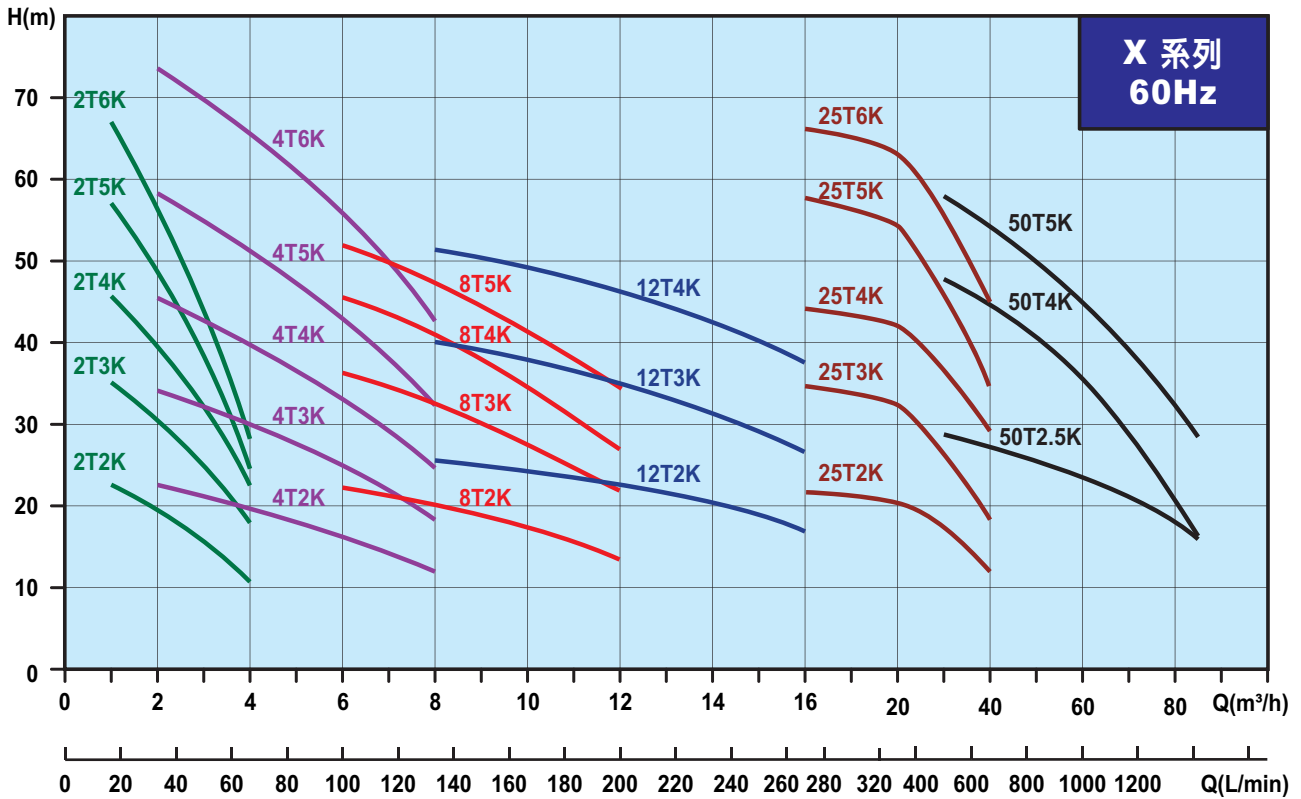

特性曲線 - 雙台交互並列

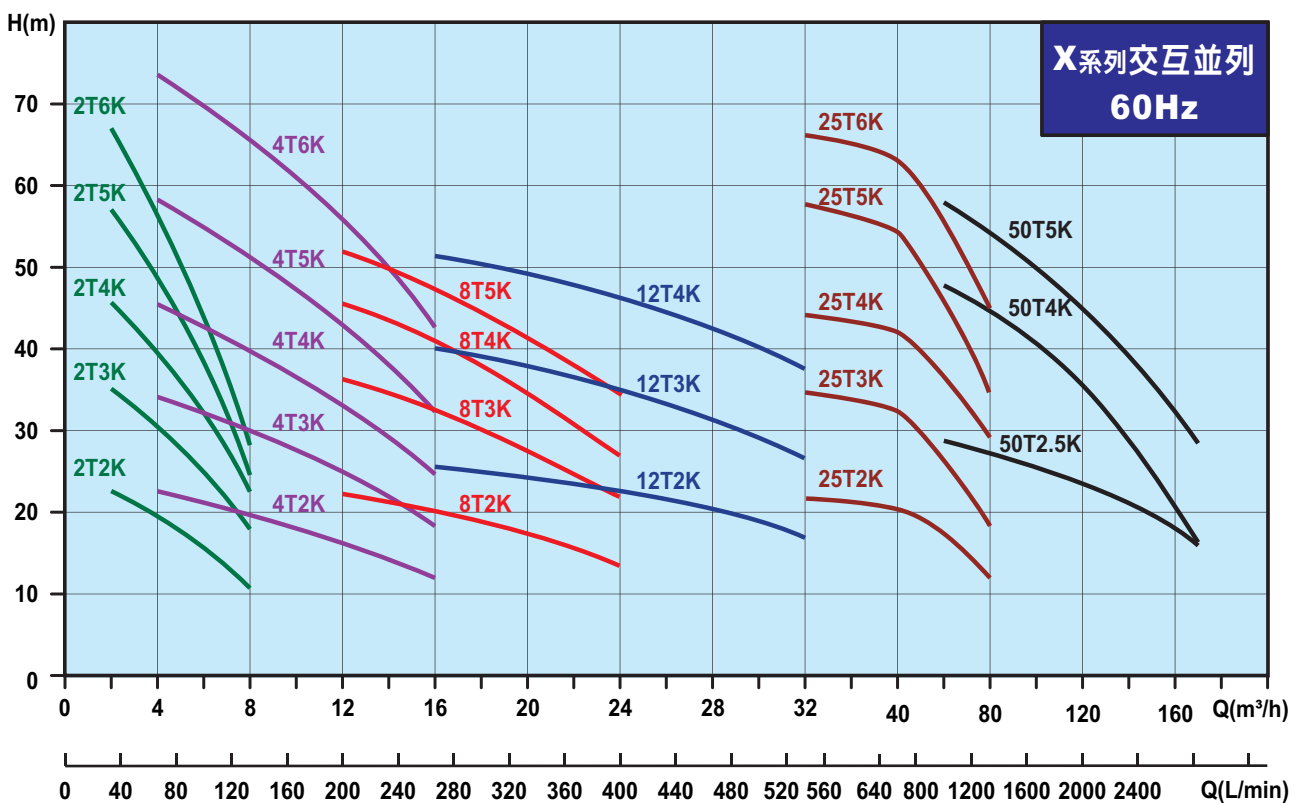

規格表 - 單台 (60Hz)

編號	型式	馬力 (HP)	電壓 (V)	壓力開關 (kg/cm ²)		入口徑 (in.)	出口徑 (in.)	最大揚程 (M)	最大水量 (L/min)
				ON	OFF				
C001	TPH2T2KX	½	1Ø 220V	1.5	2.5	1	1	26	75
C002			3Ø 220V / 380V						
C003	TPH2T2KSX		1Ø 220V						
C004			3Ø 220V / 380V						
C005	TPH2T3KX	1	1Ø 220V	2.5	3.5	1	1	40	75
C006			3Ø 220V / 380V						
C007	TPH2T3KSX		1Ø 220V						
C008			3Ø 220V / 380V						
C009	TPH2T4KX	1	1Ø 220V	3.5	4.5	1	1	53	75
C010			3Ø 220V / 380V						
C011	TPH2T4KSX		1Ø 220V						
C012			3Ø 220V / 380V						
C013	TPH2T5KX	1	1Ø 220V	4.5	5.5	1	1	68	75
C014			3Ø 220V / 380V						
C015	TPH2T5KSX		1Ø 220V						
C016			3Ø 220V / 380V						
C017	TPH2T6KX	1.3	1Ø 220V	5.5	6.5	1	1	80	75
C018			3Ø 220V / 380V						
C019	TPH2T6KSX		1Ø 220V						
C020			3Ø 220V / 380V						
C021	TPH4T2KX	1	1Ø 220V	1.5	2.5	1½	1½	26	185
C022			3Ø 220V / 380V						
C023	TPH4T2KSX		1Ø 220V						
C024			3Ø 220V / 380V						
C025	TPH4T3KX	1.3	1Ø 220V	2.5	3.5	1½	1½	40	185
C026			3Ø 220V / 380V						
C027	TPH4T3KSX		1Ø 220V						
C028			3Ø 220V / 380V						
C029	TPH4T4KX	2	1Ø 220V	3.5	4.5	1½	1½	53	185
C030			3Ø 220V / 380V						
C031	TPH4T4KSX		1Ø 220V						
C032			3Ø 220V / 380V						
C033	TPH4T5KX	2	1Ø 220V	4.5	5.5	1½	1½	64	185
C034			3Ø 220V / 380V						
C035	TPH4T5KSX		1Ø 220V						
C036			3Ø 220V / 380V						
C037	TPH4T6KX	2	1Ø 220V	5.5	6.5	1½	1½	80	190
C038			3Ø 220V / 380V						
C039	TPH4T6KSX		1Ø 220V						
C040			3Ø 220V / 380V						
C041	TPH 8T2KX	2	1Ø 220V	1.5	2.5	2	2	32	320
C042			3Ø 220V / 380V						
C043	TPH8T2KSX		1Ø 220V						
C044			3Ø 220V / 380V						
C045	TPH8T3KX	2	1Ø 220V	3	4	2	2	43	320
C046			3Ø 220V / 380V						
C047	TPH8T3KSX		1Ø 220V						
C048			3Ø 220V / 380V						
C049	TPH8T4KX	3	3Ø 220V / 380V	4	5	2	2	53	320
C050			TPH8T4KSX						
C051	TPH8T5KX	5	3Ø 220V / 380V	4.5	5.5	2	2	60	320
C052	TPH8T5KSX		3Ø 220V / 380V						

規格表 - 單台 (60Hz)

編號	型式	馬力 (HP)	電壓 (V)	壓力開關 (kg/cm ²)		入口徑 (in.)	出口徑 (in.)	最大揚程 (M)	最大水量 (L/min)
				ON	OFF				
C052	TPH12T2KX	2	1Ø 220V	1.5	2.5	2	2	29	300
C053			3Ø 220V / 380V						
C054	TPH12T2KSX		1Ø 220V						
C055			3Ø 220V / 380V						
C056	TPH12T3KX	3	3Ø 220V / 380V	3	4	2	2	43	320
C057	TPH12T3KSX		3Ø 220V / 380V						
C058	TPH12T4KX	5	3Ø 220V / 380V	4	5	2	2	56	320
C059	TPH12T4KSX		3Ø 220V / 380V						
C060	TPH25T2KX	5	3Ø 220V / 380V	1.5	2.5	3	3	25	830
C061	TPH25T2KSX		3Ø 220V / 380V						
C062	TPH25T3KX	5	3Ø 220V / 380V	3	4	3	3	41	830
C063	TPH25T3KSX		3Ø 220V / 380V						
C064	TPH25T4KX	7½	3Ø 220V / 380V	3.5	4.5	3	3	50	860
C065	TPH25T4KSX		3Ø 220V / 380V						
C066	TPH25T5KX	10	3Ø 220V / 380V	5	6	3	3	68	850
C067	TPH25T5KSX		3Ø 220V / 380V						
C068	TPH25T6KX	10	3Ø 220V / 380V	6	7	3	3	75	860
C069	TPH25T6KSX		3Ø 220V / 380V						
C070	TPH50T2.5KX	7½	3Ø 220V / 380V	2.0	3.0	4	4	33	1550
C071	TPH50T2.5KSX		3Ø 220V / 380V						
C072	TPH50T4KX	10	3Ø 220V / 380V	4	5	4	4	54	1500
C073	TPH50T4KSX		3Ø 220V / 380V						
C074	TPH50T5KX	15	3Ø 220V / 380V	5	6	4	4	67	1550
C075	TPH50T5KSX		3Ø 220V / 380V						

規格表 - 交互並列 (60Hz)

編號	型式	馬力 (HP)	電壓 (V)	壓力開關 (kg/cm ²)		入口徑 (in.)	出口徑 (in.)	最大揚程 (M)	最大水量 (L/min)
				ON	OFF				
D001	TPH2T2KX x2	½ x2台	1Ø 220V / 3Ø 220V	1.5	2.5	1	1½	26	150
D002			3Ø 380V						
D003	TPH2T2KSX x2		1Ø 220V / 3Ø 220V						
D004			3Ø 380V						
D005	TPH2T3KX x2	1 x2台	1Ø 220V / 3Ø 220V	2.5	3.5	1	1½	40	150
D006			3Ø 380V						
D007	TPH2T3KSX x2		1Ø 220V / 3Ø 220V						
D008			3Ø 380V						
D009	TPH2T4KX x2	1 x2台	1Ø 220V / 3Ø 220V	3.5	4.5	1	1½	53	150
D010			3Ø 380V						
D011	TPH2T4KSX x2		1Ø 220V / 3Ø 220V						
D012			3Ø 380V						
D013	TPH2T5KX x2	1 x2台	1Ø 220V / 3Ø 220V	4.5	5.5	1	1½	68	150
D014			3Ø 380V						
D015	TPH2T5KSX x2		1Ø 220V / 3Ø 220V						
D016			3Ø 380V						
D017	TPH2T6KX x2	1.3 x2台	1Ø 220V / 3Ø 220V	5.5	6.5	1	1½	80	150
D018			3Ø 380V						
D019	TPH2T6KSX x2		1Ø 220V / 3Ø 220V						
D020			3Ø 380V						
D021	TPH4T2KX x2	1 x2台	1Ø 220V / 3Ø 220V	1.5	2.5	1½	2	26	370
D022			3Ø 380V						
D023	TPH4T2KSX x2		1Ø 220V / 3Ø 220V						
D024			3Ø 380V						
D025	TPH4T3KX x2	1.3 x2台	1Ø 220V / 3Ø 220V	2.5	3.5	1½	2	40	370
D026			3Ø 380V						
D027	TPH4T3KSX x2		1Ø 220V / 3Ø 220V						
D028			3Ø 380V						
D029	TPH4T4KX x2	2 x2台	1Ø 220V / 3Ø 220V	3.5	4.5	1½	2	53	370
D030			3Ø 380V						
D031	TPH4T4KSX x2		1Ø 220V / 3Ø 220V						
D032			3Ø 380V						
D033	TPH4T5KX x2	2 x2台	1Ø 220V / 3Ø 220V	4.5	5.5	1½	2	64	370
D034			3Ø 380V						
D035	TPH4T5KSX x2		1Ø 220V / 3Ø 220V						
D036			3Ø 380V						
D037	TPH4T6KX x2	2 x2台	1Ø 220V / 3Ø 220V	5.5	6.5	1½	2	80	380
D038			3Ø 380V						
D039	TPH4T6KSX x2		1Ø 220V / 3Ø 220V						
D040			3Ø 380V						
D041	TPH 8T2KX x2	2 x2台	1Ø 220V / 3Ø 220V	1.5	2.5	2	3	32	640
D042			3Ø 380V						
D043	TPH8T2KSX x2		1Ø 220V / 3Ø 220V						
D044			3Ø 380V						
D045	TPH8T3KX x2	2 x2台	1Ø 220V / 3Ø 220V	3	4	2	3	43	640
D046			3Ø 380V						
D047	TPH8T3KSX x2		1Ø 220V / 3Ø 220V						
D048			3Ø 380V						
D049	TPH8T4KX x2	3 x2台	3Ø 220V	4	5	2	3	53	640
D050			3Ø 380V						
D051	TPH8T4KSX x2		3Ø 220V						
D052			3Ø 380V						
D053	TPH8T5KX x2	5 x2台	3Ø 220V	4.5	5.5	2	3	60	640
D054			3Ø 380V						
D055	TPH8T5KSX x2		3Ø 220V						
D056			3Ø 380V						

規格表 - 交互並列 (60Hz)

編號	型式	馬力 (HP)	電壓 (V)	壓力開關 (kg/cm ²)		入口徑 (in.)	出口徑 (in.)	最大揚程 (M)	最大水量 (L/min)
				ON	OFF				
D057	TPH12T2KX x2	2 x2台	1Ø 220V / 3Ø 220V	1.5	2.5	2	3	29	600
D058			3Ø 380V						
D059	TPH12T2KSX x2		1Ø 220V / 3Ø 220V						
D060			3Ø 380V						
D061	TPH12T3KX x2	3 x2台	3Ø 220V	3	4	2	3	43	640
D062			3Ø 380V						
D063	TPH12T3KSX x2		3Ø 220V						
D064			3Ø 380V						
D065	TPH12T4KX x2	5 x2台	3Ø 220V	4	5	2	3	56	640
D066			3Ø 380V						
D067	TPH12T4KSX x2		3Ø 220V						
D068			3Ø 380V						
D069	TPH25T2KX x2	5 x2台	3Ø 220V	1.5	2.5	3	4	25	1660
D070			3Ø 380V						
D071	TPH25T2KSX x2		3Ø 220V						
D072			3Ø 380V						
D073	TPH25T3KX x2	5 x2台	3Ø 220V	3	4	3	4	41	1660
D074			3Ø 380V						
D075	TPH25T3KSX x2		3Ø 220V						
D076			3Ø 380V						
D077	TPH25T4KX x2	7½ x2台	3Ø 220V	3.5	4.5	3	4	50	1720
D078			3Ø 380V						
D079	TPH25T4KSX x2		3Ø 220V						
D080			3Ø 380V						
D081	TPH25T5KX x2	10 x2台	3Ø 220V	5	6	3	4	68	1700
D082			3Ø 380V						
D083	TPH25T5KSX x2		3Ø 220V						
D084			3Ø 380V						
D085	TPH25T6KX x2	10 x2台	3Ø 220V	6	7	3	4	75	1720
D086			3Ø 380V						
D087	TPH25T6KSX x2		3Ø 220V						
D088			3Ø 380V						
D089	TPH50T2.5KX x2	7½ x2台	3Ø 220V	2.0	3.0	4	6	33	3100
D090			3Ø 380V						
D091	TPH50T2.5KSX x2		3Ø 220V						
D092			3Ø 380V						
D093	TPH50T4KX x2	10 x2台	3Ø 220V	4	5	4	6	54	3000
D094			3Ø 380V						
D095	TPH50T4KSX x2		3Ø 220V						
D096			3Ø 380V						
D097	TPH50T5KX x2	15 x2台	3Ø 220V	5	6	4	6	67	3100
D098			3Ø 380V						
D099	TPH50T5KSX x2		3Ø 220V						
D100			3Ø 380V						

外型尺寸 TPH2T /4T X (mm)

● 圖1. TPH 2T - X

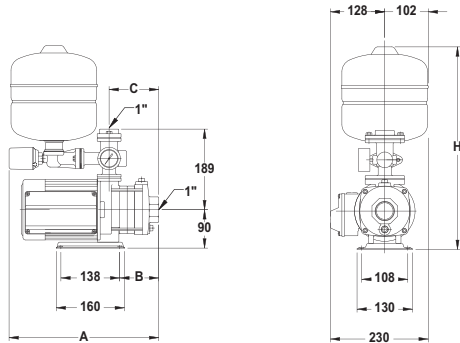

● 圖2. TPH 2T - X (3Ø)

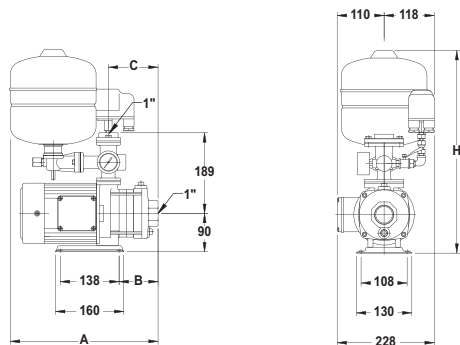

● 圖3. TPH 2T4KX ~ 6KX (3Ø)

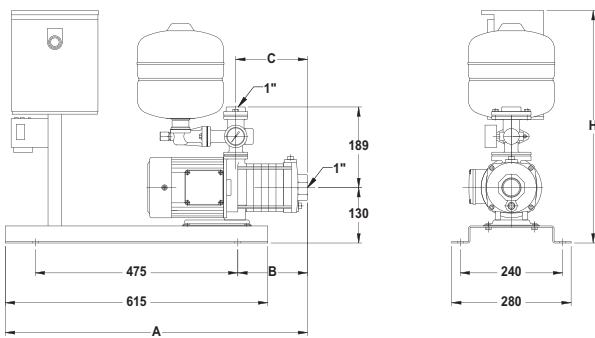

● 圖4. TPH 4T - X

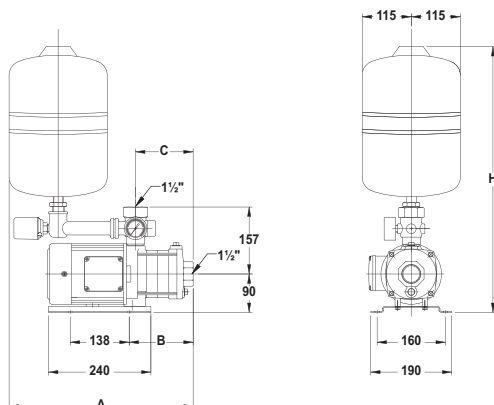

● 圖5. TPH 4T - X (3Ø)

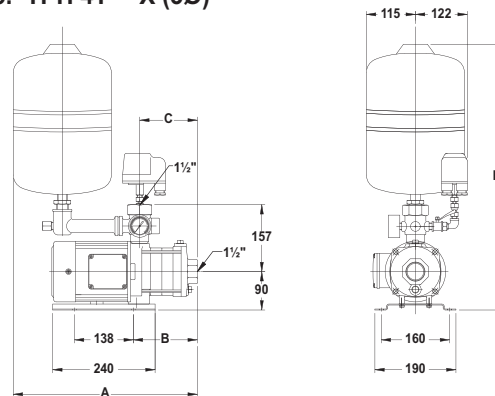

● 圖6. TPH 4T4KX ~ 6KX (3Ø)

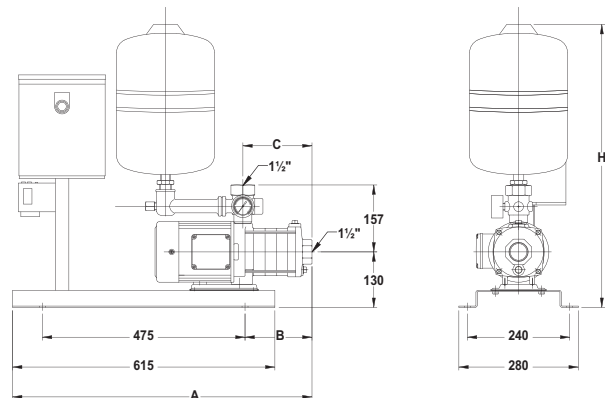

型式	A	B	C	H	壓力桶 (L)	例圖
TPH2T2KX 1Ø	334	74	99	433	3.5	1
TPH2T3KX 1Ø	351	92	117	475	5	2
TPH2T4KX 1Ø	369	110	135	475	5	2
TPH2T5KX 1Ø	399	128	153	475	5	3
TPH2T6KX 1Ø	417	146	171	475	5	3
TPH4T2KX 1Ø	393	123	108	443	3.5	4
TPH4T3KX 1Ø	432	150	135	624	12	5
TPH4T4KX 1Ø	459	177	162	624	12	5
TPH4T5KX 1Ø	486	204	189	624	12	6
TPH4T6KX 1Ø	503	231	216	624	12	6
TPH4T2KX 3Ø	390	123	108	443	3.5	5
TPH4T3KX 3Ø	432	150	135	624	12	5
TPH4T4KX 3Ø	702	157	162	664	12	5
TPH4T5KX 3Ø	729	184	189	664	12	6
TPH4T6KX 3Ø	756	211	216	664	12	6

外型尺寸 8T/ 12T/ 25T/ 50T (mm)

● 圖1. TPH 8T / 12T - X

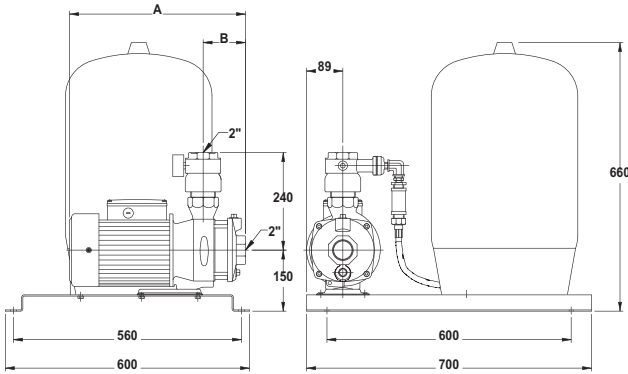

● 圖2. TPH 8T / 12T - X

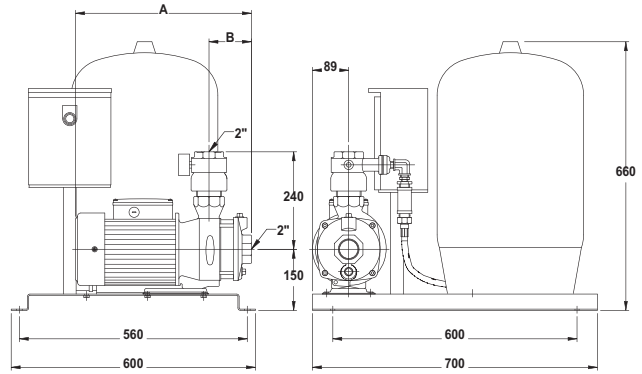

● 圖3. TPH 25T - X

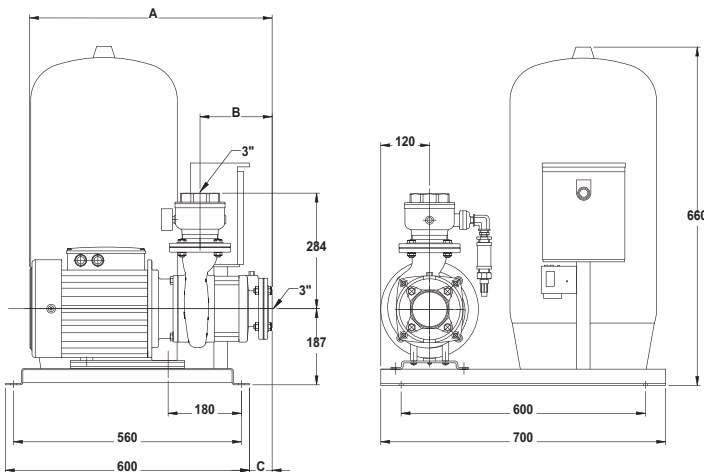

● 圖4. TPH 50T - X

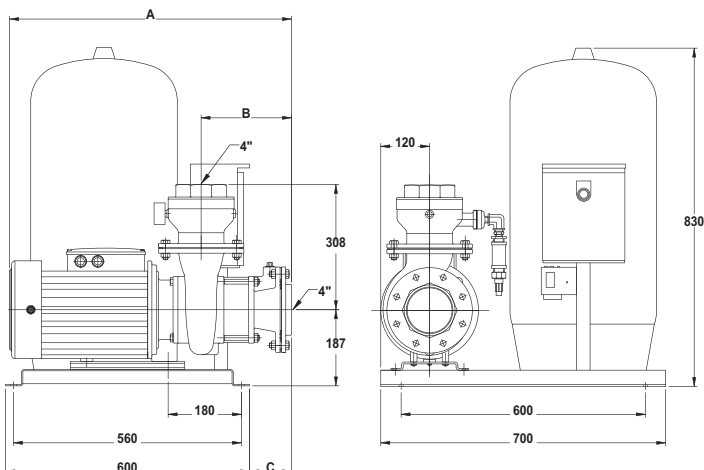

型式	A	B	C	壓力桶 (L)	例圖
TPH8T2KX	370	75	-	50	1
TPH8T3KX	407	107	-	50	1
TPH8T4KX	435	107	-	50	2
TPH8T5KX	467	139	-	50	2
TPH12T2KX	375	75	-	50	1
TPH12T3KX	435	107	-	50	2
TPH12T4KX	435	107	-	50	2
TPH25T2KX	538	120	-2	50	3
TPH25T3KX	598	180	58	50	3
TPH25T4KX	598	180	58	50	3
TPH25T5KX	708	240	118	50	3
TPH25T6KX	708	240	118	50	3
TPH50T2.5KX	583	162	43	80	4
TPH50T4KX	693	222	103	80	4
TPH50T6KX	743	222	103	80	4

外型尺寸 (mm)

• TPH 2T / 4T - X x2台

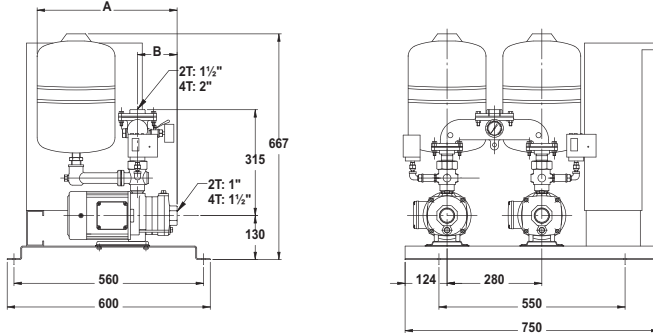

• TPH 8T / 12T - X x2台

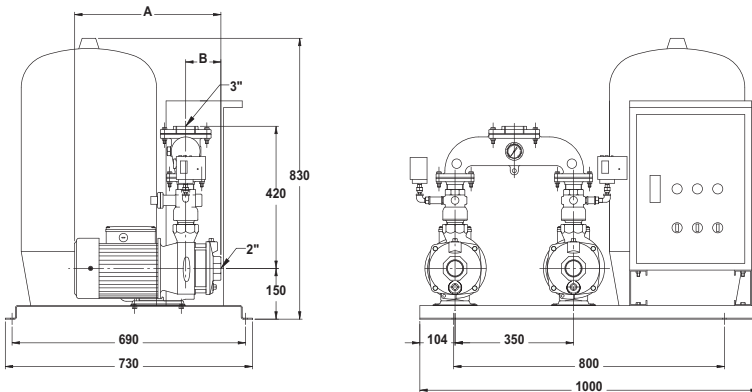

• TPH 25T - X x2台

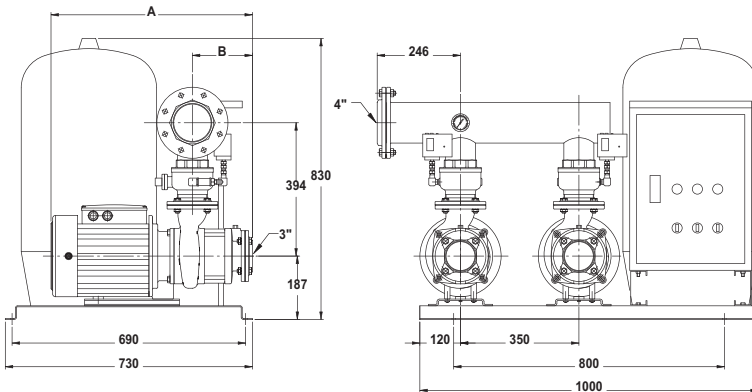

• TPH 50T - X x2台

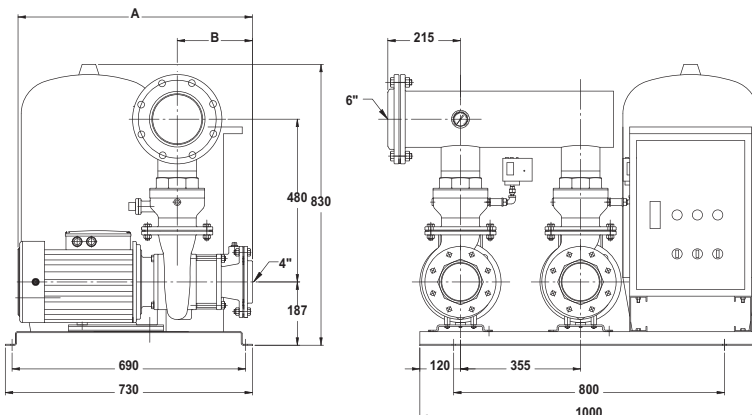

型式	A	B	壓力桶 (L)	例圖
TPH2T2KX x2	395	99	3.5 x2只	1
TPH2T3KX x2	413	117	5 x2只	1
TPH2T4KX x2	431	135	5 x2只	1
TPH2T5KX x2	449	153	5 x2只	1
TPH2T6KX x2	467	171	5 x2只	1
TPH4T2KX x2	404	108	3.5 x2只	1
TPH4T3KX x2	431	135	12 x2只	1
TPH4T4KX x2	458	162	12 x2只	1
TPH4T5KX x2	485	189	12 x2只	1
TPH4T6KX x2	512	216	12 x2只	1
TPH8T2KX x2	370	75	80	2
TPH8T3KX x2	407	107	80	2
TPH8T4KX x2	435	107	80	2
TPH8T5KX x2	467	139	80	2
TPH12T2KX x2	375	75	80	2
TPH12T3KX x2	435	107	80	2
TPH12T4KX x2	435	107	80	2
TPH25T2KX x2	537.5	120	80	3
TPH25T3KX x2	597.5	180	80	3
TPH25T4KX x2	597.5	180	80	3
TPH25T5KX x2	707.5	240	80	3
TPH25T6KX x2	707.5	240	80	3
TPH50T2.5KX x2	583	162	80	4
TPH50T4KX x2	693	222	80	4
TPH50T5KX x2	743	222	80	4



大井泵浦工業股份有限公司