

Service instructions

100mm Paperless chart recorder

INTRODUCTION

This document describes the disassembly of the 'front end' of a 100 mm paperless chart recorder, down as far as display backlight replacement. Removal of the main 'micro' board and backlight inverter board are included, but for replacement/retrofit instructions for input/output boards, power supply units and the serial communications and USB option boards, the document HA028908U100 should be referred to.

SAFETY PRECAUTIONS

Ensure that the recorder is isolated from supply voltage for at least 15 minutes before starting to work on it. This period will allow the high voltages associated with the inverter board to dissipate safely, and will also allow the power supply unit to cool down. The user should be aware however, that areas of high temperatures might still exist even after this period has elapsed.

STATIC ELECTRICITY

CAUTION



These procedures involve the handling of components which are susceptible to damage caused by the discharge of static electricity. All relevant personnel must be aware of static handling procedures. It is recommended that a static safe container be available into which any circuit board, removed from the recorder, may be placed.

DUST INGRESS

When replacing the display or backlighting, it is essential to keep the front face of the display and the rear face of the touch screen as clean as possible. The use of polythene, or latex gloves is recommended when handling the display unit. If possible, the replacement procedure should be carried out in a clean area.

Particles of dust not only appear unsightly, but may also affect the performance of the touch screen, in extreme circumstances, causing a continuous 'press' to be perceived by the recorder,

	 <p>invensys EUROTHERM EUROTHERM LIMITED</p> <p>Faraday Close, Durrington, Worthing, West Sussex, BN13 3PL Telephone: +44 (0)1903 268500 Facsimile: +44 (0)1903 265982 e-mail: info.uk@eurotherm.com Website: http://www.eurotherm.co.uk</p>
--	--

TOP COVER REMOVAL

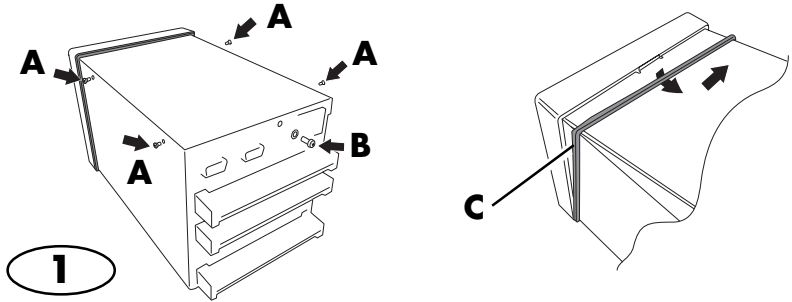

With the recorder removed from the panel, remove the top plate, by removing the four Torx-headed screws 'A' and the pan-head Pozidriv screw 'B', and then lifting the cover up and out from under the gasket (C).

CARD CAGE REMOVAL

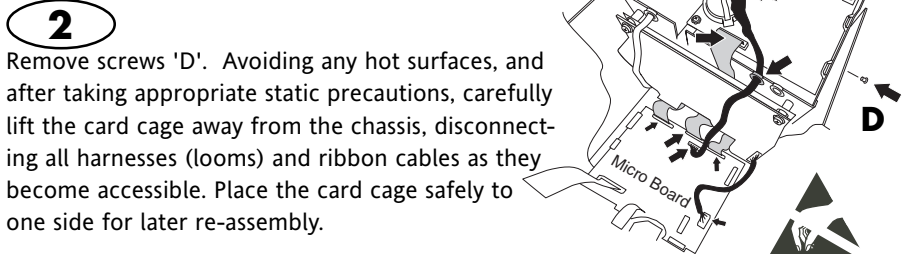

Remove screws 'D'. Avoiding any hot surfaces, and after taking appropriate static precautions, carefully lift the card cage away from the chassis, disconnecting all harnesses (looms) and ribbon cables as they become accessible. Place the card cage safely to one side for later re-assembly.

MAIN BOARD REMOVAL

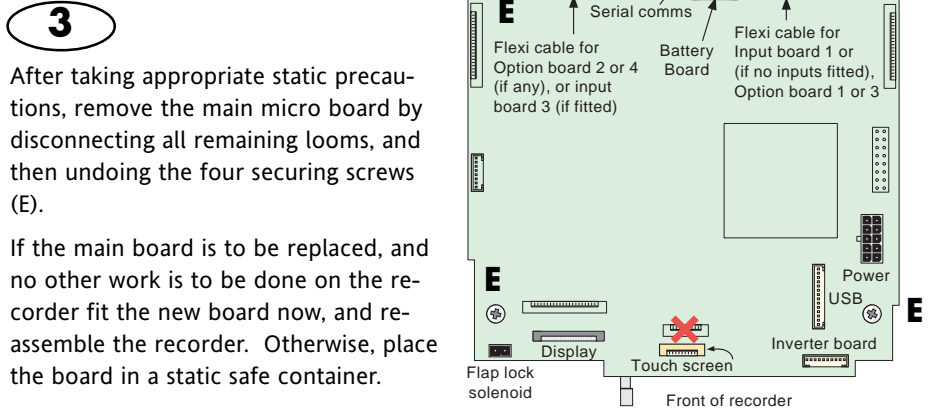

After taking appropriate static precautions, remove the main micro board by disconnecting all remaining looms, and then undoing the four securing screws (E).
If the main board is to be replaced, and no other work is to be done on the recorder fit the new board now, and re-assemble the recorder. Otherwise, place the board in a static safe container.

Note: If the type of memory device is to be changed (from Flash to SD card or vice-versa), a new media plate must be fitted - see page 4

TRANSMITTER POWER SUPPLY WIRING

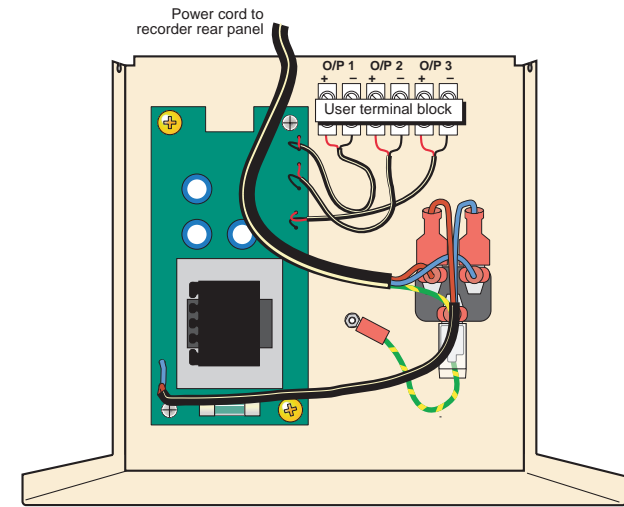

Fit circuit board fuse according to the intended supply voltage
Fuse type = Type 'T'

Supply voltage	Fuse rating	Part Number
115V ac	100 mA	CH050012
230V ac	63mA	CH050630

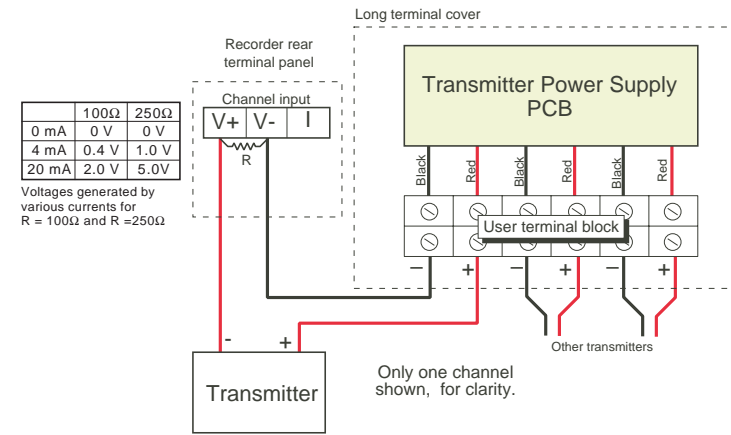

R (minimum spec) = 1.4W, ± 1%. 100Ω or 250Ω as required (see table)

TRANSMITTER POWER SUPPLY

The retrofitting of the transmitter power supply is carried out from the rear of the recorder.

CAUTION

The Transmitter Power Supply option may not be used with low voltage or dc supplies.

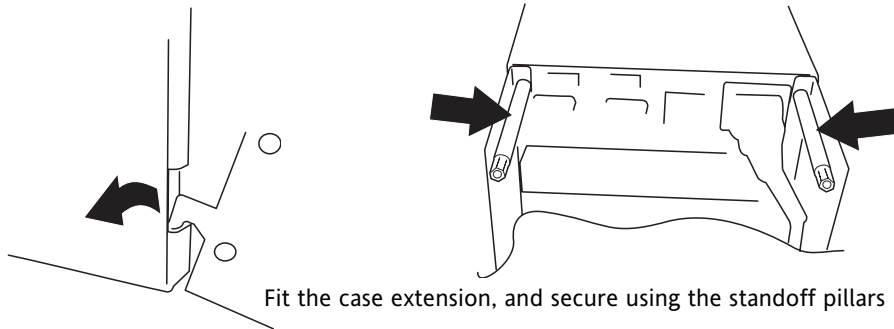

Fit the rear cover, and wire the power supplies as shown below.

Connect the supply voltage cable between the long terminal cover and the recorder rear panel, and use a tie-wrap to secure it to the lance in the side plate.

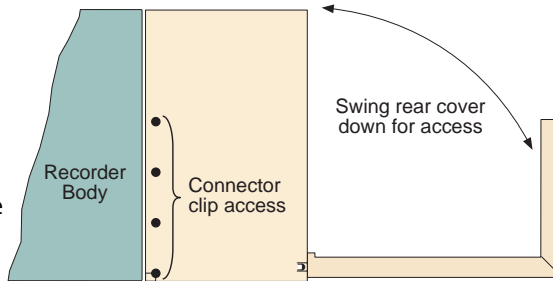

If required, connectors can be removed by inserting a suitable screwdriver through the relevant apertures, to compress the connector side catches.

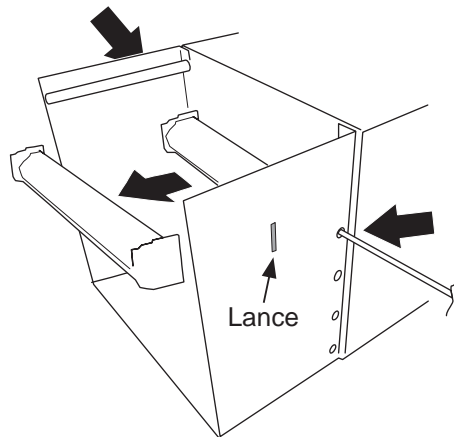

DISPLAY HOUSING REMOVAL

4

Undo the four Torx-headed screws (F), and carefully lift the display housing away from the chassis.

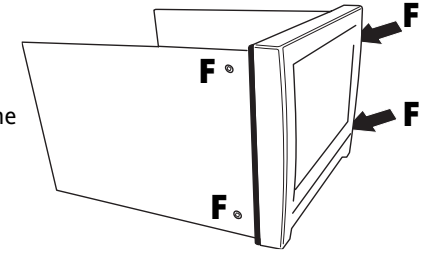

INVERTER BOARD REMOVAL

The inverter board is removed only if:

- The inverter board is to be replaced and/or
- The display unit is to be replaced.

Otherwise, go to 'Backlight replacement' (step 7).

5

Disconnect the two Backlight connectors (G)

Remove the inverter board (secured by screws 'I'). Place the board in a static safe area for later use in re-assembly, or replace the board, and re-assemble the recorder.

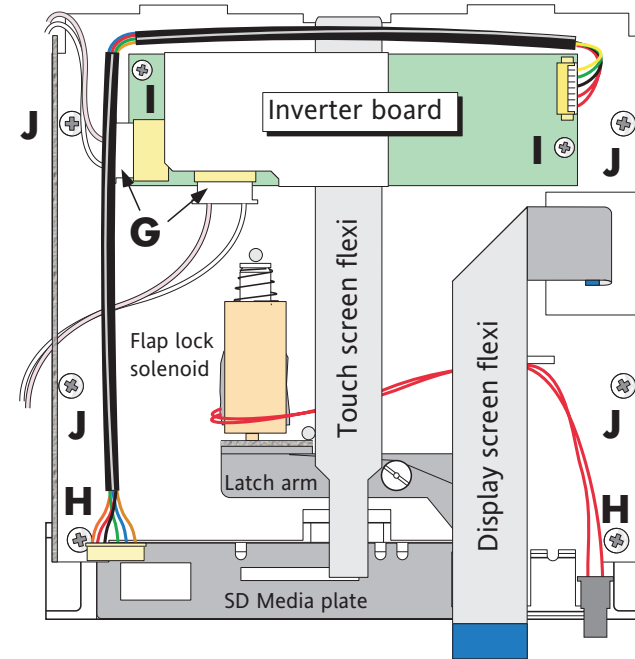

Stylus holder not shown, for clarity

DISPLAY REPLACEMENT

6

Peel the touch screen flexi cable away from the screen plate (double-sided, sticky pad). Undo the two securing screws (H).

Whilst taking care not to damage any of the harnesses or flexible cables, ease the screen plate/display assembly out of the housing. (If a flap lock is fitted, then disengage it before attempting to lift the assembly away from the fascia.)

The Display can now be removed (screws J), a new one fitted, and the recorder re-assembled.

After re-assembly, carry out the Touch screen calibration procedure as described in Annex B of the user guide.

Note: when re-assembling the recorder, it is essential that any shakeproof washers fitted under the screws 'J' are refitted. Otherwise, the display screen may not be properly secured.

MEDIA PLATE

This item is designed to help the user to guide the flash or SD card into its connector on the main micro board. Fitted at the bottom of the display housing, and retained by the screen plate, this flexible strip also has cutouts for the USB port and for the lock catch (if fitted) and also contains areas which allow the status LEDs to be viewed.

The variants are shown below, as viewed from the inside of the recorder.

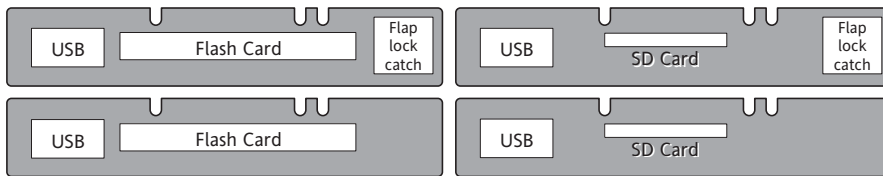

BACKLIGHT REPLACEMENT

7

It is recommended that this procedure be carried out in a clean environment, and that the person carrying out the procedure wear polythene or latex gloves.

If not previously done, remove the display housing from the chassis as described in step 4, above. Remove screws 'H' and disconnect the backlight connectors 'G'.

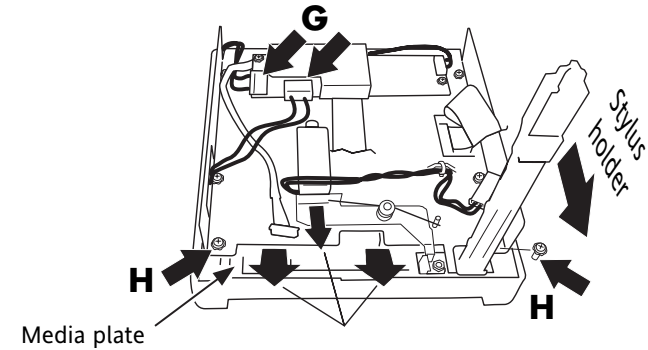

Lift the display unit out of the housing. (If a flap lock is fitted, then disengage it whilst lifting the display unit away from the display housing.) The stylus holder can be removed for convenience (or replacement).

Observe the routing of the backlight harnesses.

At the left edge of the display unit, locate the two backlighting units, and carefully ease them out of their slots, as shown. The new units can now be slid into position, and the recorder re-assembled.

When reassembling, please ensure that the harness to the upper backlight follows the routing shown (i.e. it does not pass through the screen plate side aperture as the lower harness does).

After re-assembly, carry out the Touch screen calibration procedure as described in Annex B of the user guide.

