

GAST 4080 旋片式真空泵,压缩机

为什么选择我?

我们是旋片式压缩机与真空泵,具有显著的优势,可以提供流畅且几乎没有脉冲的气流,并不需要气缸,我们结构紧密,安装简单,震动与噪音小,便于维修,并且低电流启动,占用空间很小.



优点

- 无油式25" HG,45CFM,15PSI
- 双功能18" HG,25CFM,9PSI
- 结构坚固
- 维护成本低

应用

点钞机,曝气设备,呼吸机,纹理喷涂设备,循环治疗设备,磁带驱动空气轴承,天气预报设备,水槽曝气,曝气池,塑料焊接设备,通风设备,家庭污水冲氧处理,呼吸机,电镀槽搅拌,废油燃烧器

规格型号

| 型号 | 电机参数 | 转速RPM | | 功率 | | 重量 |
|----------------|------------------|-------|------|----|------|--------|
| | | 60Hz | 50Hz | HP | KW | |
| 无油式 | | | | | | |
| 4080-P101 | 不包含 | 1725 | 1425 | 5 | 3.70 | 41.9Kg |
| 4080-V102 | 不包含 | 1725 | 1425 | 3 | 2.20 | 41.9Kg |
| 4080-D103 | 不包含 | 1725 | 1425 | 5 | 3.70 | 39.6Kg |
| 双功能 | | | | | | |
| 4080-P127-T339 | 208~230/460;60-3 | 1725 | ---- | 5 | 3.70 | 57.2Kg |
| 4080-V128-T338 | 208~230/460;60-3 | 1725 | ---- | 3 | 2.20 | 57.2Kg |
| 4080-D129-T339 | 208~230/460;60-3 | 1725 | ---- | 5 | 3.70 | 60.8Kg |





产品尺寸(mm,英寸)

产品性能(公制,英制)

真空泵

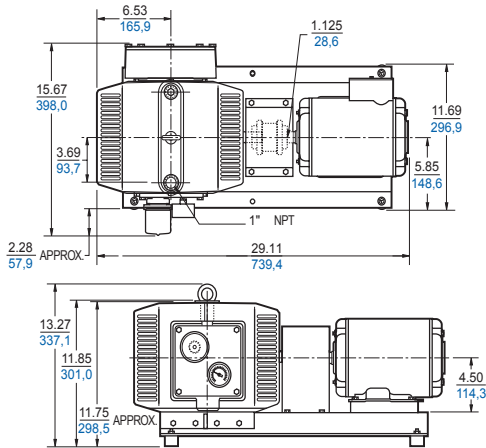

压缩机

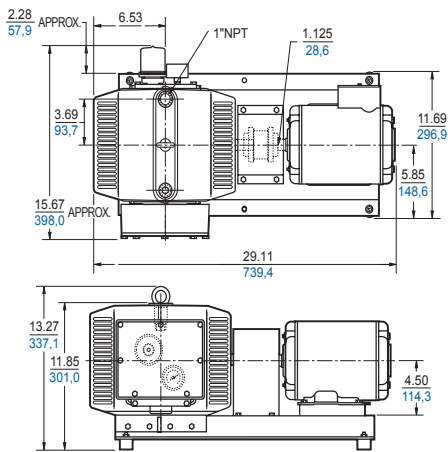

双功能

