

Power Supply Units Sensor Control Units



- PS series
- IP series
- P2F (sensor control unit)



● Power supply unit for sensors

- PS series high-capacity, slim
- IP series UL Standard-compliant (E-94173)

■ Type

Model	Power supply	Operation mode	Output mode	Timer feature	Power supplied to sensor
PS3N	AC 100~240V ±10% 50 / 60Hz	AND logic operation	Relay contact output	Not provided	12 VDC, 200 mA max.
PS3N-SR			Triac output		
PS3F		AND logic operation CLOCK AND logic operation	Relay contact / open collector	Provided	
PS3F-SR			Triac / open collectors		
IP1F	AC 100 · 110 / 200 · 220V ±10% 50 / 60Hz	Reverse operation Timer function selectable	Relay contact/ voltage output	Provided	12 VDC, 100 mA max.
IMP1F					12 VDC, 150 mA max.
IP1N		Reverse operation		Not provided	12 VDC, 100 mA max.

IP series

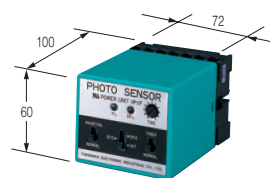

PS series

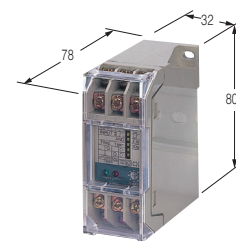

(With terminals and panel cover)

Rating/Performance/Specification (PS series)

Model	PS3N	PS3N-SR	PS3F	PS3F-SR
Power supply	12 – 24 VDC ±10% 50/60 Hz			
Power consumption	10W max.			
Input	NPN open collector input (*1) Input mode: L mode		NPN open collector input (*1) Input mode: H/L switching Minimum input duration: 20 us (*2)	
Operation mode	AND logic operation		AND/CLOCK AND logic operation (On-delay, off-delay, one-shot, timer disabled) Timer : 0.1-1s, 1-10s	
Output mode	<ul style="list-style-type: none"> Relay contact output 1c Rating: 2A (250V AC) max. resistance load 	<ul style="list-style-type: none"> Triac output 1a Photocoupler-insulated zero-cross system Load voltage: 75-250 VAC Load current: 2 Arms Residual ON voltage :1.5 Vrms 	<ul style="list-style-type: none"> Relay contact output 1c Rating: 2A (250V AC) max. resistance load NPN open collector output Rating: 100mA (30V DC) max. Residual ON voltage: 1 V max. 	<ul style="list-style-type: none"> Triac output 1a Photocoupler-insulated zero-cross system Load voltage: 75-250 VAC Load current: 2 Arms Residual ON voltage :1.5 Vrms NPN open collector output Rating: 100mA (30V DC) max. Residual ON voltage : 1 V max.
Power supplied to sensor	12V DC ±10% 200 mA max. (short circuit protection circuit provided) (*3)			
Response time	5 ms max.	12 ms max.	<ul style="list-style-type: none"> Relay output: 5 ms max. NPN open collector output Activation: 20 μs max Deactivation: 50 μs max. 	<ul style="list-style-type: none"> Triac output: 12 ms max. NPN open collector output Activation: 20 μs max Deactivation: 50 μs max.
Indicator	POWER: power indicator (green LED) OUTPUT: operation indicator (red LED)			
Volume (VR)	—		TIME: delay timer adjustment selectable between 0.1-1 s and 1-10 s	
Switch (SW)	—		INPUT 1: input mode H/L selector switch INPUT 2 AND- f AND/CLOCK AND selector switch TIME: delay time range selector switch 1s: between 0.1 and 1 s 10s: between 1 and 10 s TIMER: timer function selector switch (Two switches combined to select between on-delay, off-delay, one-shot and timer disabled)	
Case material	ABS resin			
Connection	Terminal block (with M3.5 screws, terminal block width 8.1 mm)			
Mounting	DIN rail (35 mm) or screw mounting.			
Mass	120 g max.		150 g max	

Environmental Specification

Ambient temperature	-10 - +55 °C *3 (non-freezing)
Storage temperature	-40 - +70 °C (non-freezing, non-condensing)
Ambient humidity	35-85%RH (non-condensing)
Protective structure	IP40
Vibration	10-55 Hz / 1.5 mm amplitude / 2 hours each in 3 direction
Dielectric withstanding	1,500 VAC for 1 minute (*4)
Shock	1000 m/s ² / 2 times each in 3 directions
Insulation resistance	500 VDC, 20 MΩ or higher (*4)

(*1) For voltage input, use voltage of 3 V max. for L mode and 8 V min. (30 V max.) for H mode.

(*2) Minimum input duration for one-shot (OST) output to be triggered.

(*3) When the ambient temperature rises above 40 °C, refer to and follow the Derating table.

(*4) Between individual inputs and outputs for case, between input and output for power supply and between input and output for relay contact or triac output. The internal circuit 0 V (0 V of power supply for sensor) and the power supply for the control unit are connected through a capacitor (0.001 μF).

Derating table

When the ambient temperature exceeds 40 °C, the output current value decreases as shown in the figure on the right. Line (A) indicates a range in which adjacent installation is permitted.

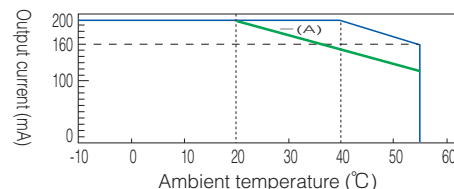

Output Circuit and Connection

- Triac output (PS3N-SR, PS3F-SR)

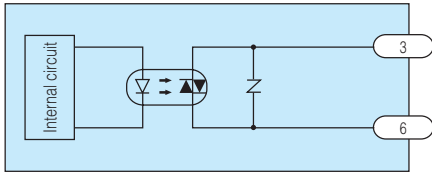

- Relay output (PS3N, PS3F)

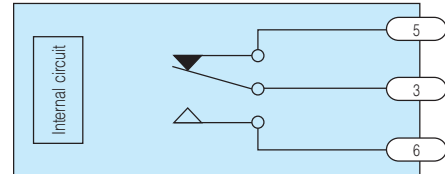

- Open collector output (PS3F, PS3F-SR)

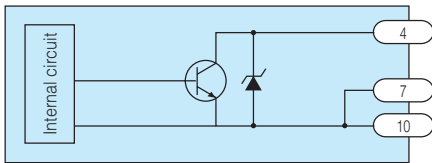

Connection Examples

PS3N

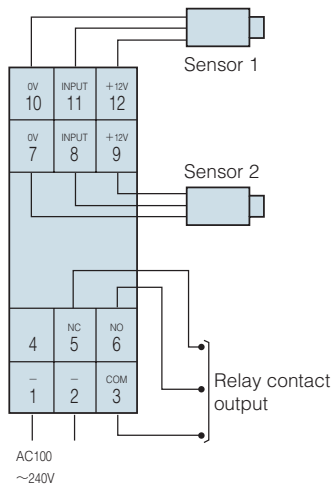

PS3N-SR

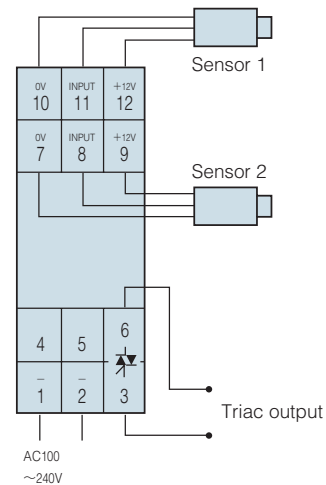

A shorting bar is provided between Terminals (7) and (8).
When using two sensors for AND logic operation, remove the shorting bar.
When not using two sensors, short-circuit Terminals (7) and (8).

PS3F

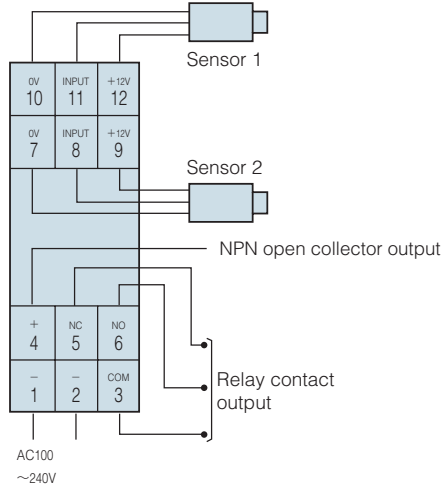

PS3F-SR

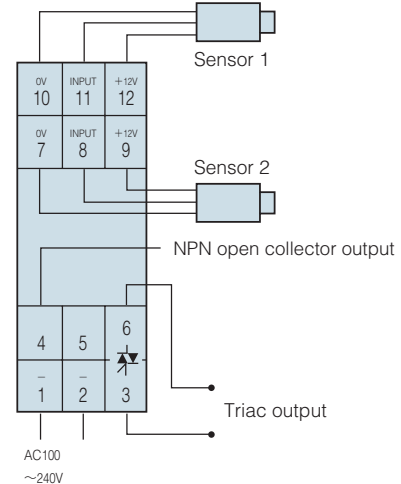

Panel Description

PS3F
PS3N-SR

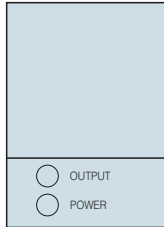

OUTPUT: operation indicator (red)
POWER: power indicator (green)

PS3F
PS3F-SR

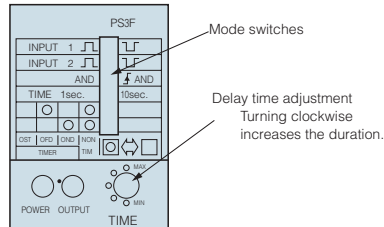

OUTPUT: operation indicator (red)
POWER: power indicator (green)

Mode Switches

- This switch selects between sensor signal input modes.
 : output activated when sensor input signal turns H.
 : output activated when sensor input signal turns L.

Note) When not using the second sensor (INPUT 2), set the **INPUT 2** switch at .

- This switch is for enabling logic operation with two sensors.
 Note) When not using two sensors, set the switch at AND.

Setting at **AND** enables AND logic output with two sensors.

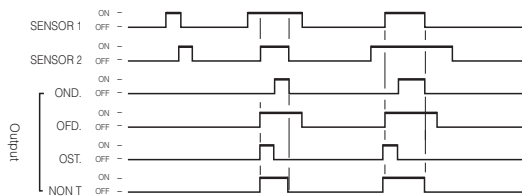

Setting at AND enables judgment of the input state of Sensor 1 signal at the moment of input of Sensor 2 signal, which is output. Generally, the output is in a one-shot (OST) signal.

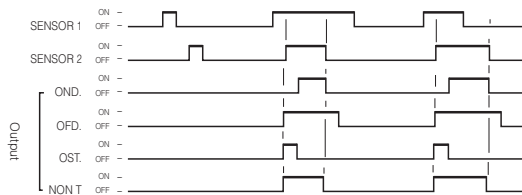

- This switch is for selecting between delay time ranges.

 - 1s** Setting at 1 s allows duration setting between 0.1 and 1 s.
 - 10s** Setting at 1 s allows duration setting between 1 and 10 s.

- This selector switch is for specifying the timer function. Select the function according to the application.

Timer Operation

When the basic ON-OFF operation is not sufficient for intended output signals, timer functions are available to apply output signals.

- On-delay: cancels short detection signals.

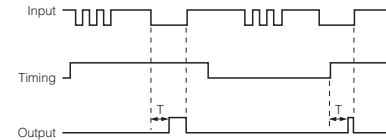

- Off-delay: extends output signals by a certain period.

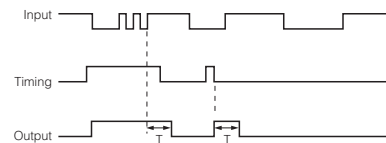

- One-shot: output signals of a certain width starting at the moment of detection.

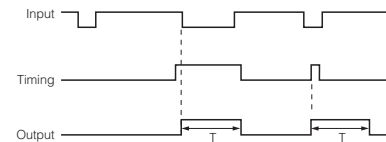

- Basic operation

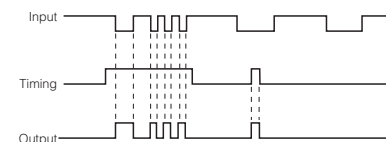

Dimensions (in mm)

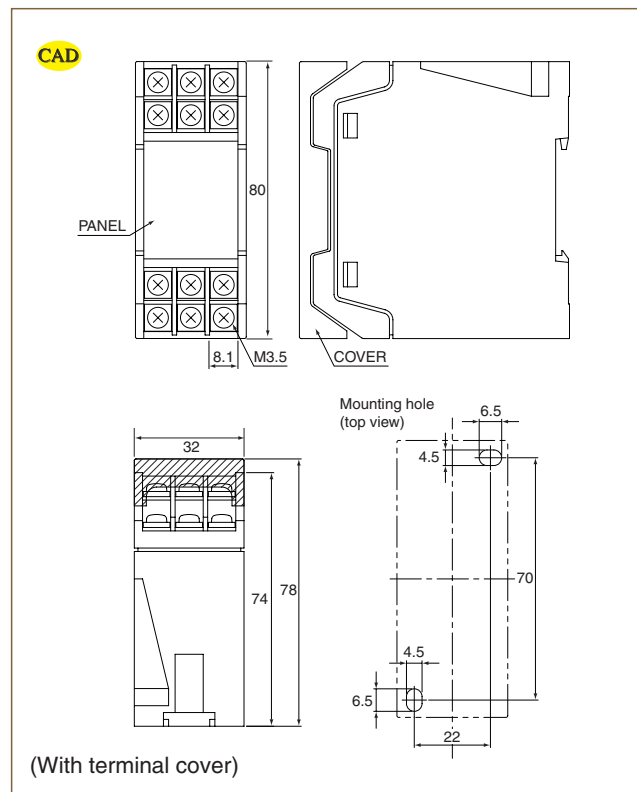



- UL Standard certified (E-94173) IP1N/IP1F
- Compact size
- IP1F: Integrated multifunctional timer (0.1-10 s variable, on-delay/off-delay/one-shot)

Rating/Performance/Specification (IP series)

Model	IP1F	IMP1F	IP1N
Power supply	AC100V · 110 / 200V · 220V ±10% 50 / 60Hz		
Power consumption	5 VA max.		
Operation mode	ON-OFF	Timer switching (On-delay, off-delay, one-shot,) timer disabled Delay time: 0.1-10 s	ON-OFF
Output mode	Relay contact output 1c Rating : 5A (250VAC) resistance load Voltage output Rating : output impedance 1 KΩ (12VDC)		
Power supplied to sensor	12VDC ±5% 100mA max. (150 mA max. for IMP1F)		
External gating	Contact input/voltage input [H: 6V min., L: 1V min.]		
Response time	Sensor input:	relay contact output 25 ms max. Voltage output 0.5 ms max.	
	External gating input:	Voltage output 5 ms max.	
Indicator	P.L. : power indicator (green LED) OP.L : power indicator (red LED)		
Volume (VR)	TIME: Delay time adjustment provided (0.1-10 s variable)		—
Switch (SW)	Operation mode selector switch ON.D On-delay OF.D Off-delay OST One-shot Input operation reverse switch: INVERTING : input reversed NORMAL : same as input Timer enabled/disabled switch TIMER : timer enabled NORMAL : timer disabled	Input operation reverse switch INVERTING : input reversed NORMAL : same as input	
Case material	Polycarbonate		
Connection	Plug-in terminal block (3.5 mm screws)		
Mass	400 g max.		
Notes	Terminal block (TB14) provided		

Environmental Specification

Ambient temperature	-10 - +55 °C (non-freezing)
Ambient humidity	35-85%RH (non-condensing)
Protective structure	IP20
Vibration	10-55 Hz / 1.5 mm amplitude / 2 hours each in 3 direction
Shock	1000 m/s ² / 2 times each in 3 directions
Dielectric withstanding	1,500 VAC for 1 minute
Insulation resistance	500 VDC, 20 MΩ or higher

Input Circuit

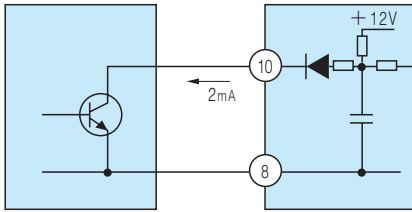

- Setting the input operation reverse switch to **NORMAL** activates the output relay when the input signal is activated (ON). Setting the switch to **INVERTING** activates the relay when the input signals is deactivated (OFF).

Output Circuit

Relay output

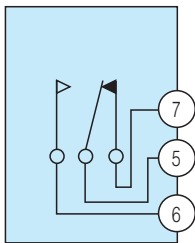

Voltage output

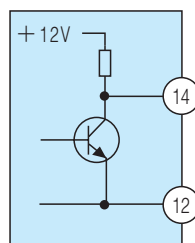

External Gating

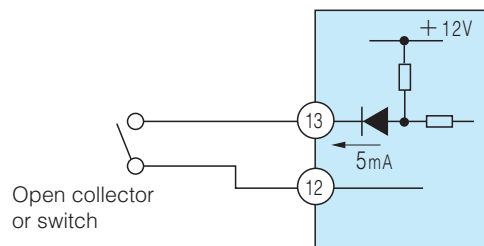

- Closing (12) and (13) disables the internal circuit.
- When not using external gating, leave them open.

Panel Description

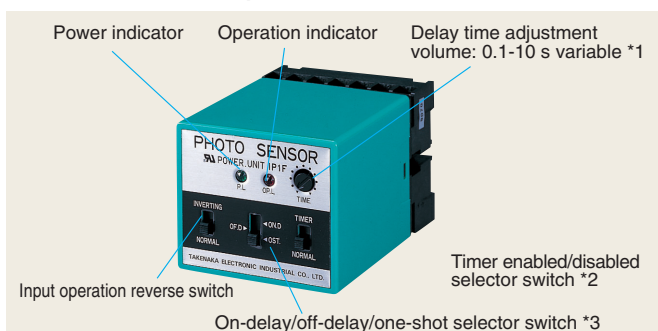

*1, *2 and *3 are not provided for IP1N.

Connection

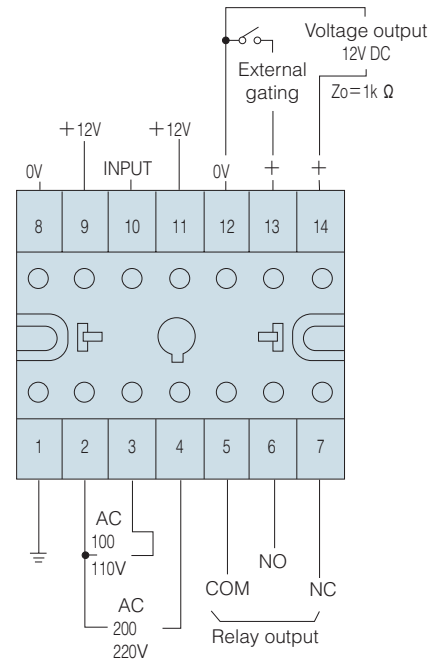

Terminals (12) and (13) compose an external gating circuit. The internal circuit functions when they are open.

Dimensions (in mm)

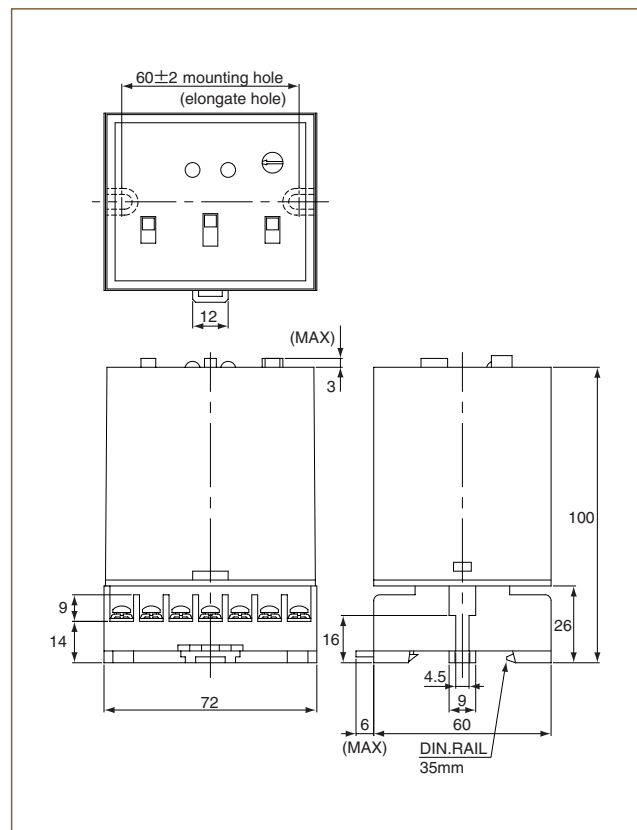



● Programmable control capability provides complex detection and operation

- Combinations of logic codes, which represent 8 combinations of input active states of sensors, and function codes, which represent 8 types of programmed output operations, namely (1) 2-channel, (2) AND, (3) OR, (4) XOR, (5) LATCH, (6) CL.AND, (7) GATE MEMORY and (8) Edge control provide 64 types of complex detection and operation. Complex operations that conventionally required the design of complex control circuits or more than one control unit are now available in a single unit.

■ Type

Model	Power supply	Operation mode	Output mode	Timer feature	Power supplied to sensor
IP2F	AC 100~120V / AC 200~240V ±10% · 50 / 60Hz	Selectable with digital switch (see the description of operations for codes) Timer switching	2 relay contacts (1a) 1 open collector	Provided	12 VDC, 100 mA max.

■ Panel Description

Power indicator
Illuminated when power is supplied

Output 1 operation indicator

Output 2 operation indicator
(Illuminated when Output 1/2 is activated)

Function code
Rotary digital switch for enabling one of the preprogrammed 8 output operations

Logic code
Rotary digital switch for enabling one of the preprogrammed sensor input states (activated for ON <L> or for OFF <H>)

Delay time adjustment (*)
Turning clockwise increases duration

Delay time range selector (*)
Selects between 0.1-1 second, 1-10 seconds and timer disabled

Timer selector (*)
Selects between on-delay, off-delay and one-shot

(Items marked with * are applicable to Output 1 only.)

- OND (On-delay)···Cancels signals that are shorter than the set duration.
- OFD (Off-delay)···Extends output signals by the set duration.
- OST (One-shot)···Provides signals of the set duration starting at detection

Rating/Performance/Specification

Type	IP2F
Power supply	AC100~120V / AC200~240V ±10% 50 / 60Hz
Power consumption	3 VA max.
Operation mode	Selectable with digital switches *1 Timer function selectable (applicable to Output 1 only) (between on-delay, off-delay, one-shot, timer disabled) Delay time: 0.1-1 s, 1-10 s
Output mode	2 relay output (1a x 2) Rating: 5 A (250 VAC) resistance load 1 open collector output Rating: 50 mA (30VDC) max.
Input mode	2 inputs 1 external gating input
Power supplied to sensor	12VDC ±1V 100mA
External gating	Contact input
Response time	Relay contact output 25 ms max. Open collector output 0.5 ms max.
Indicator	P.L.: power indicator (green LED) OUT1: Output 1 indicator (red LED) OUT2: Output 2 indicator (red LED)
Volume (VR)	TIME: delay timer adjustment (0.1-1 s/1-10 s variable)
Switch (SW)	<ul style="list-style-type: none"> • CODE: digital switch (rotary, 2 digits) Digit 1: logic code Digit 2: function code } *1 • Timer switch 1-10 sec: 1-10 s variable (with volume mentioned above) 0.1-1 sec: 0.1-1 s variable NON T.: timer disabled • Operation mode selector switch ON.D On-delay OF.D Off-delay OST One-shot
Case material	Resin
Connection	Plug-in terminal block (with 3.5 mm screws)
Mass	450 g max.
Notes	*1 See Logic Codes (Digit 1) and Function Codes (Digit 2) for details of operation. • Terminal block (TB 14) provided.

Environmental Specification

Ambient temperature	-10 - +55 °C (non-freezing)
Ambient humidity	35-85%RH (non-condensing)
Vibration	10-55 Hz / 1.5 mm amplitude / 2 hours each in 3 direction
Shock	1000 m/s ² / 2 times each in 3 directions
Dielectric withstanding	1500 VAC for 1 minute
Insulation resistance	500 VDC, 20 MΩ or higher

IP2F

Input Circuit and External Gating

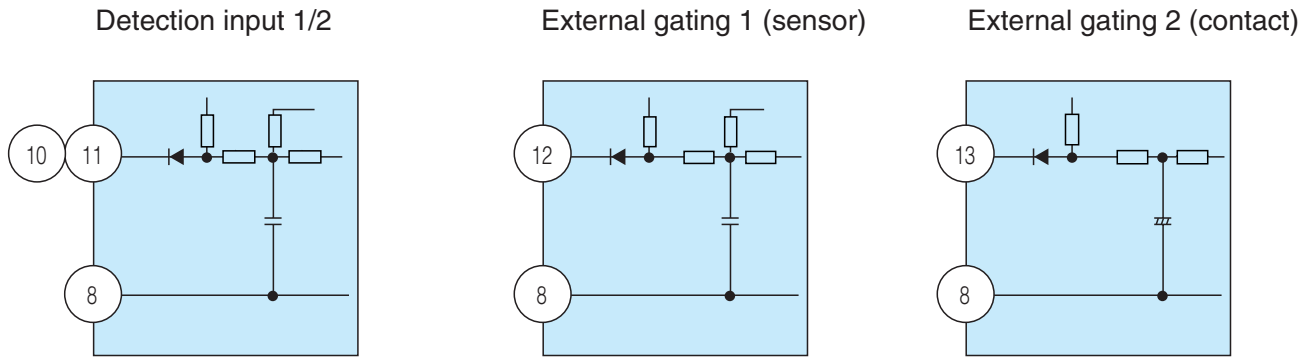

Output Circuit

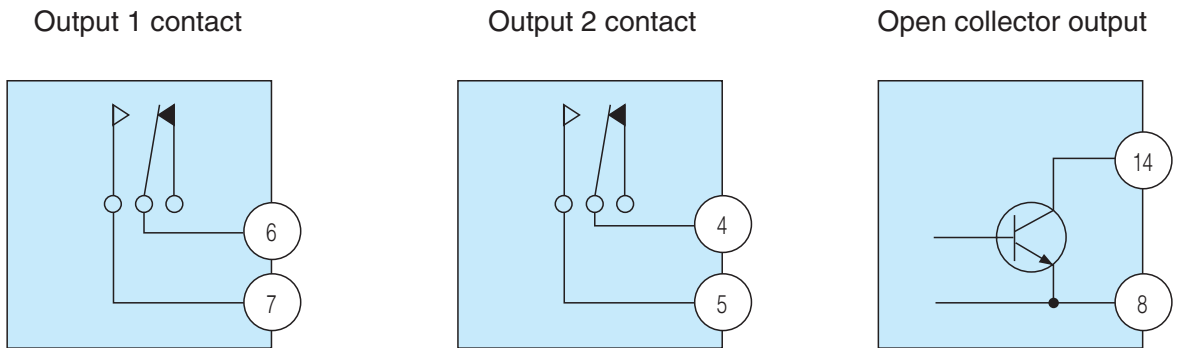

Connecting

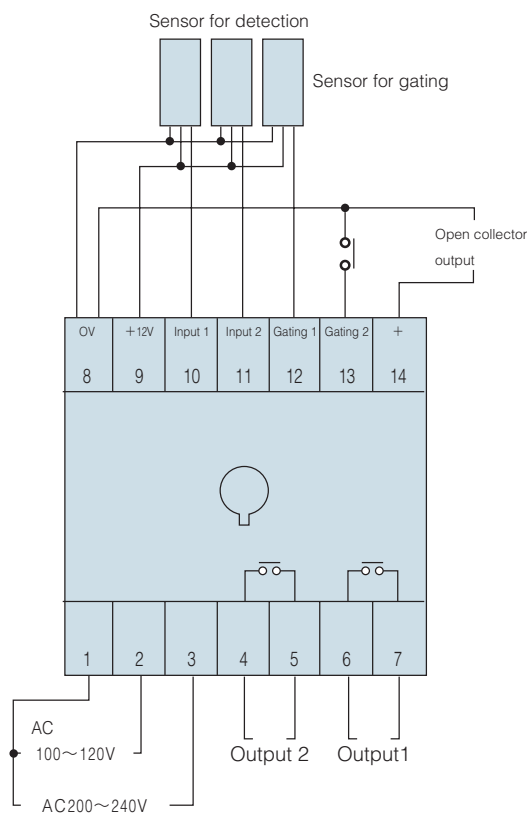

Dimensions (in mm)

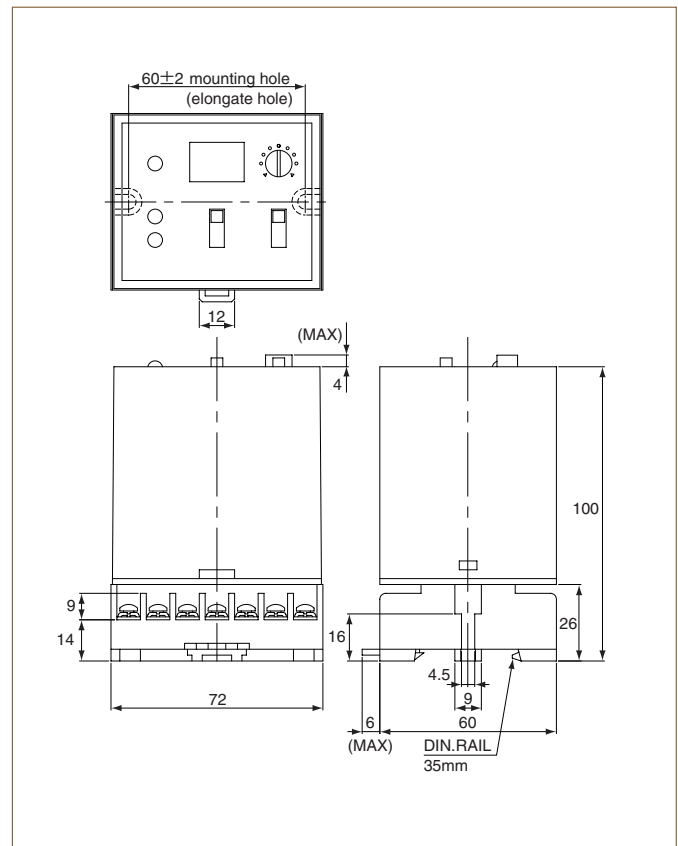

Logic Codes (Digit 1)

Code No.	0	1	2	3	4	5	6	7
Output 1	○	●	○	●	○	●	○	●
Output 2	○	○	●	●	○	○	●	●
Gate	○	○	○	○	●	●	●	●

○ Activated for ON (L) / ● Activated for OFF (H)

The value of the first digit specifies a combination of input active states. ○ means activated for ON (L) and ● activated for OFF (H).

Any unused input must be set at the value marked with ●.

Function Codes (Digit 2) (output operation specified by combination of 3 inputs)

(1) 2-channel

Inputs 1 and 2 are respectively ANDed with gating input and Outputs 1 and 2 are individually activated. This setting makes the unit function as a 2-channel control unit. The timer is provided for Output 1 only.

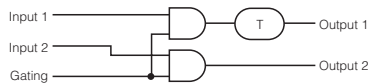

(2) AND

Inputs 1, 2 and gating input compose an AND circuit. Three inputs are ANDed and the signal is output as Output 1.

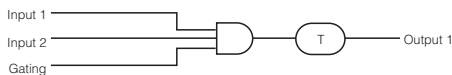

(3) OR

Inputs 1 and 2 are ORed, which is ANDed with gating and the resulting signal is output as Output 1. Photo sensors allow wired ORing, for which all sensors should be connected with one point regardless of Input 1 or 2.

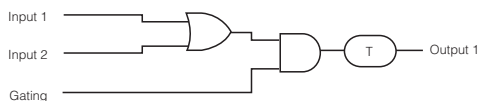

(4) XOR

XOR stands for exclusive OR, which activates output when the states of Inputs 1 and 2 do not agree. When Input 1 is supplied with detection signal and Input 2 with comparator signal and gating signal is input, the comparator functions only when the gate signal is input. Output signal is activated when the signal states do not agree.

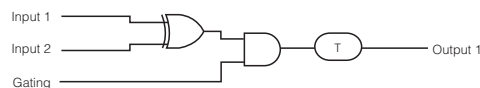

(5) LATCH

May be used for self-holding.

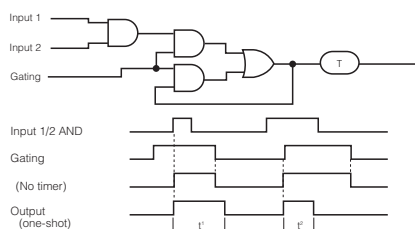

(6) CL.AND

The states of Inputs 1 and 2 are determined at the moment gating signal is input (0.5 ms) for output.

Generally, the output is a one-shot signal and applications usually involve photo sensors as in the detecting the orientation of labels.

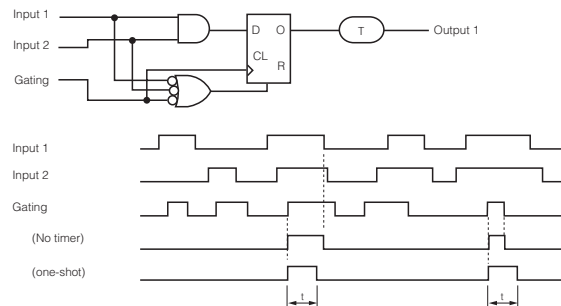

(7) GATE MEMORY

Whether Input 1 or 2 is supplied while gating signal is input is temporarily stored and the stored state is output at the fall of gating signal.

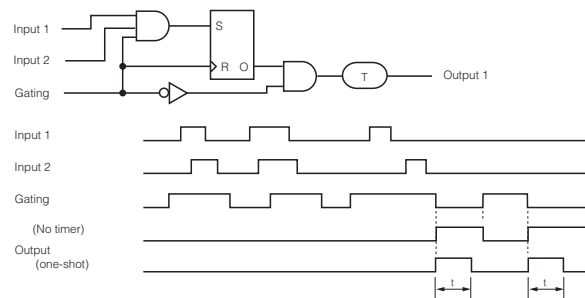

(8) Edge control

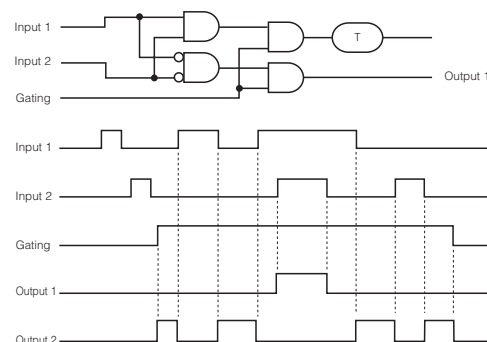

Applications

Work size differentiation

The height of a robot arm with a chuck is controlled according to the height of the work (material) carried on a conveyor. Two sets of through-beam photo sensors are used. The second sensor (bottom) is also used for timing and 2 signals are output.

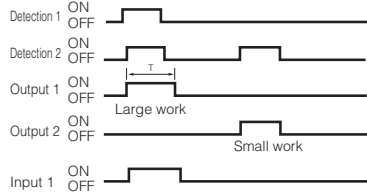

	Operation mode of sensor	Code setting	
		Function code	Logic code
Detection 1	Dark-ON mode	1	2
Detection 2	Dark-ON mode	1	2

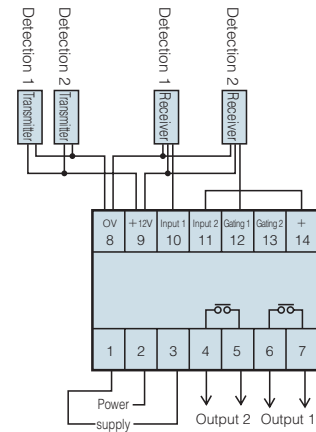
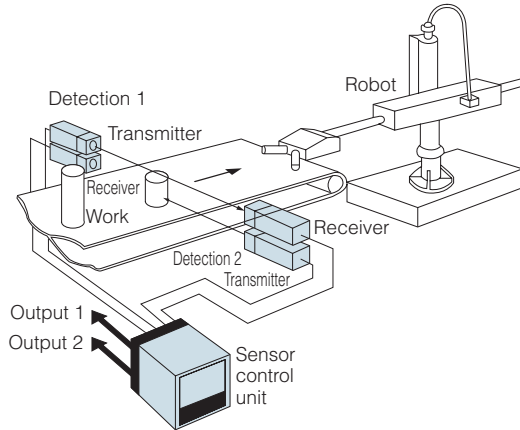

Detection of level of liquid in transparent container

Through-beam photo sensors are used to see if the level of the liquid in transparent containers is as specified. Photo sensors with sensitivity adjustment are suitable for this purpose, which allows sensitivity setting that does not activate the sensors with the container only but activates with the liquid.

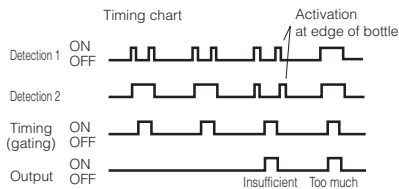

	Operation mode of sensor	Code setting	
		Function code	Logic code
Detection 1	Dark-ON mode	4	1 or 2
Detection 2	Dark-ON mode		
Timing	Light-ON mode		

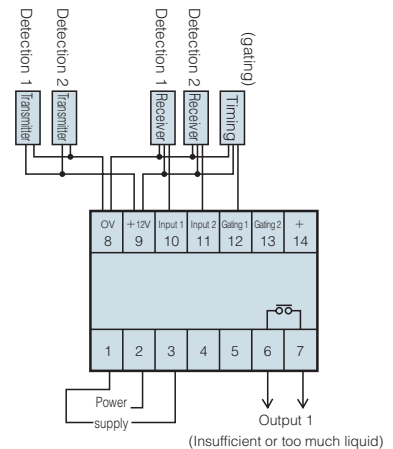
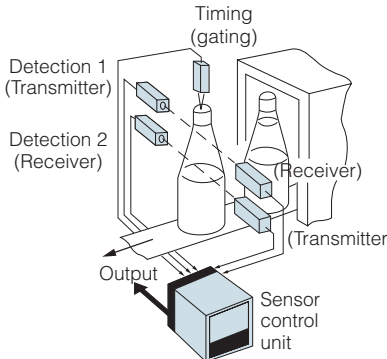

Detection of broken pins of diodes, resistors, etc.

Fiber optic sensors are used to check for any broken pins on both sides of taped electronic components such as diodes and resistors. Components with shorter pins due to breakage or bend are judged as defective.

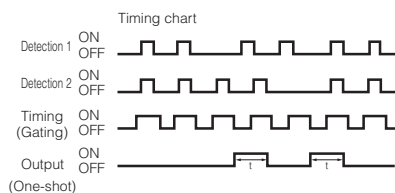

	Operation mode of sensor	Code setting	
		Function code	Logic code
Detection 1	Light-ON mode	7	0
Detection 2	Light-ON mode		
Timing	Light-ON mode		

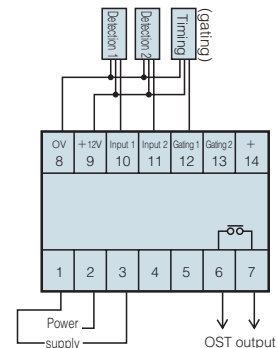
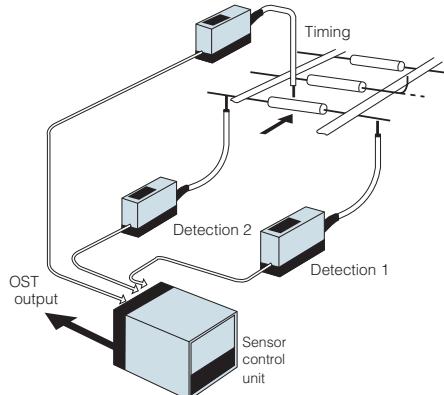

Applications

Detection of marks on transparent glass

A through-beam fiber optic sensor is used to see if manufacturer logos, etc. are printed on transparent glass. A diffuse-reflective type photo sensor that uses reflection from the glass for detection is used for timing. Products for which the fiber optic sensor is never activated during output of the other sensor (logo print missing) are judged as defective.

	Operation mode of sensor	Code setting	
		Function code	Logic code
Detection 1	Dark-ON mode	7	2
Timing	Light-ON mode		

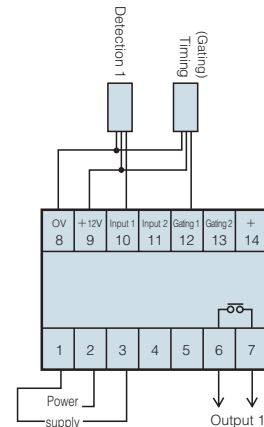
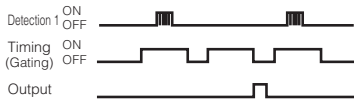
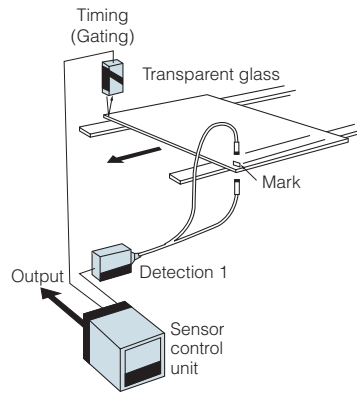

Detection of medical gauze

In the inspection process of sticking plasters, through-beam photo sensors are used for detection of gauze on plastic bandage. For the detection of gauze, a photo sensor with sensitivity adjustment is suitable, which allows sensitivity setting that does not activate the sensor with the plastic bandage only but activates with the gauze and bandage combine.

	Operation mode of sensor	Code setting	
		Function code	Logic code
Detection 1	Dark-ON mode	7	2
Timing	Light-ON mode		

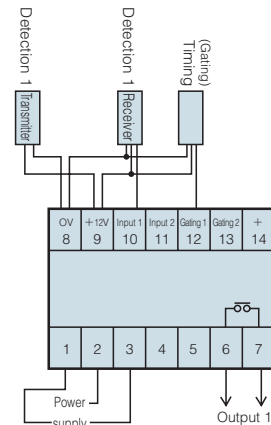
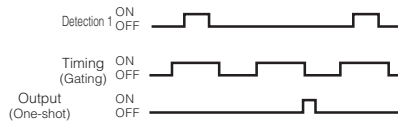
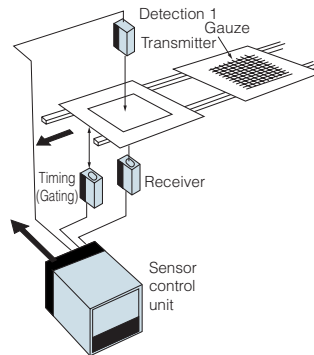

Prevention of double operation on pressing machine

A sensor is used to detect any pressed work (material) remaining without being ejected (sensor beam not blocked) to prevent double pressing, which prevents damage to the die.

	Operation mode of sensor	Code setting	
		Function code	Logic code
Detection 1	Dark-ON mode	7	6
Timing	Limit switch		

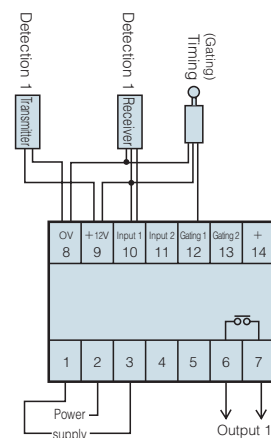
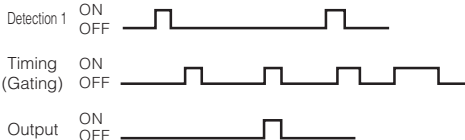
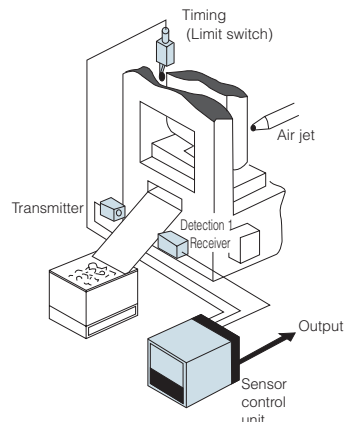

代理以下品牌:

- ◇日本山武 YAMATAKE/azbil ◇台湾阳明 FOTEK ◇美国霍尼韦尔 HONEYWELL
◇日本竹中 TAKEX/SEEKA ◇日本大仓 OHKURA ◇ASEE 安圣光纤线专业生产厂
◇日本基恩斯 KEYENCE ◇日本理研 RIKEN 光幕/镜片◇台湾 moujen

记录仪:大仓 OHKURA, 山武 YAMATAKE 千野 CHINO,神港 SHINKO,东邦 TOHO,横河 YOKOGAWA
安全光幕: 安圣 ASEE, SSG20 对射光幕, 神视 SUNX, 阳明 fotek, 理研 RIKEN 鲜光 SUN KWANG
光纤放大器:山武 YAMATAKE 竹中 TAKEX 神视 SUNX,基恩斯 KEYENCE 阳明 fotek 奥托尼克斯

主营产品: 安全光幕、记录仪、光纤放大器、光纤线、接近开关、光电开关、行程开关、计数器、计时器、温控器、固态继电器、热电偶、PT100 热电阻、燃烧保护继电器、火焰检测器、PLC、变频器、触摸屏、步进电机及驱动器、各国进口品牌记录纸、色带、记录笔

欢迎访问我公司网站:www.Lanseanet.com

深圳市创丰机电设备有限公司

深圳市宝安九区澎柏白金酒店商务大厦 917 室

手机:13143436561 直线: 0755-81642429

传真: 0755-61658146

联系人:钱军辉

网址 www.Lanseanet.com E-mail:sensorschina@126.com

服务 QQ:50827480 MSN:qianqun@163.com