

IN-LINE REFRACTOMETER

PRM-85

Cat.No. 3571



CALCULATION DISPLAY SECTION

For Controlling Concentration of Various Liquids in In-Line Mode!



DETECTION SECTION

 **ATAGO**

Outline

The PRM-85 is an ultimate in-line refractometer with ATAGO's updated cutting-edge technology. The PRM-85 is designed to measure the liquid concentration (index of refraction), by utilizing the refraction phenomenon of light at the boundary plane between the plane of a small prism exposed at a part of the detection section of the refractometer, and the liquid to be measured.

Concentration (%), water contents (%) or mixing ratio of various solutions can be controlled continuously by installing this refractometer on the piping used in the manufacturing plant of foods, medicines, etc. and for liquid supply devices of various industries, washing device, dilution and mixing devices.

Features

The PRM-85 continuously measures refractive index(nD), Brix, or the concentration (%) of the liquid flowing through a pipe.

With automatic temperature compensation according to the sample liquid, correct concentration or Brix is always displayed and output.

An alarm output is provided, if the measured value of the sample exceeds control limits, by setting high- and low-limit values.

Liquid can be controlled on a real-time basis.

The PRM-85 measures a wide range of concentration.

The detection section is equipped with air cooling fin, allowing measurement of sample liquids with temperatures up to 100°C.

The PRM-85 measures without the influence of coloration, muddiness, viscosity or pressure (within the range of normal pressures) of the sample.

Applications

●Control of mixing, diluting and concentrating processes at food manufacturing plants.

Fruit juices, soft drinks, coffee, cocoa, alcoholic drinks, tomato paste, sauce, ketchup, vinegar, pickled liquid, wort, condensed milk, etc.

●Control of fermenting processes

Soy sauce, alcohol, etc.

●Monitoring of change of liquid at the time of product change in food production lines.

●Check of concentration of waste liquid.

Sugar waste liquid, alcohol, chemicals, etc.

●Control of hydrocarbon detergents or petrochemical detergents mixed with dirt.

●Control of the concentration of dilute solution.

Cutting oil, lubricating oil, quenching oil, water-soluble detergent, starch, NaOH, alkaline solution, surfactant, amino acid, ammonia, ethanol, cesium chloride, sodium carbonate, cupric sulfate, citric acid, acetic acid, sodium glutamate, formalin, ethylene glycol, propylene glycol, coating solution, sizing agent, fire extinguishing solution, rust preventives, etc.

●Liquid of concentration of various solutions.

Liquid sugars, fructose, glucose, syrups, albumen, edible oils, vegetable oils, sugar cane/sugar beet, IPA, DMF, PVA, H₂O₂, methylene chloride, coolant and brine solutions, undiluted solutions for Chinese medicines, injections, citrus oil, glycerin, polymer, gelatins, proteins, lotions, etc.

Components

DETECTION SECTION

The detection section is installed in a section of the piping, and detects the refractive index of the liquid flowing through the line.

The detection signals are electrically processed by the primary electrical processing in the power supply. As a result, the refractive index data and temperature data are output from as a digital signal from the RS-232C terminal.

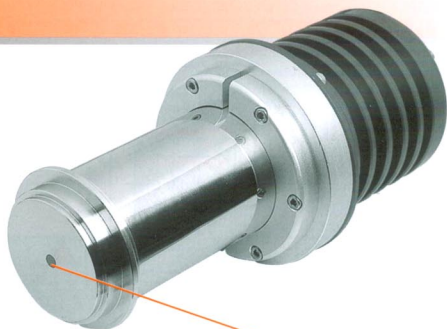

Prism

CALCULATION DISPLAY SECTION

The calculation display section serves as a data controller to execute signals (refractive index, temperature) received from the detection section into Brix, concentration values, automatic temperature compensation, and other calculation processing. These arithmetically processed measured values are digitally displayed.

This calculation display section also provides various functions, such as recorder output(4 to 20mA), RS-232C output, and high-low limiter to control the allowable range of the high- and low-limit values of the product flowing through a line.

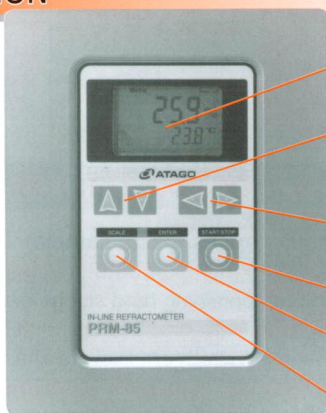

Display panel

Numerical value change keys

Cursor movement keys

START/STOP key

ENTER key

SCALE key

POWER SUPPLY SECTION

The power supply section supplies power to the detection section, and converts the RS-232C signal (refractive index and temperature) from the detection section to RS-485 and sends it to the calculation display section.

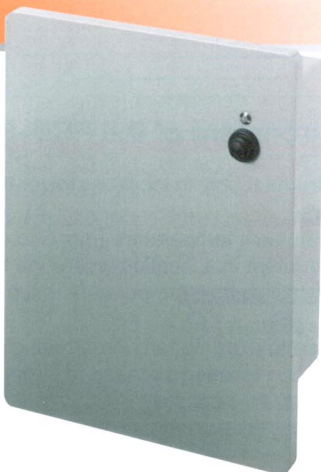

Construction

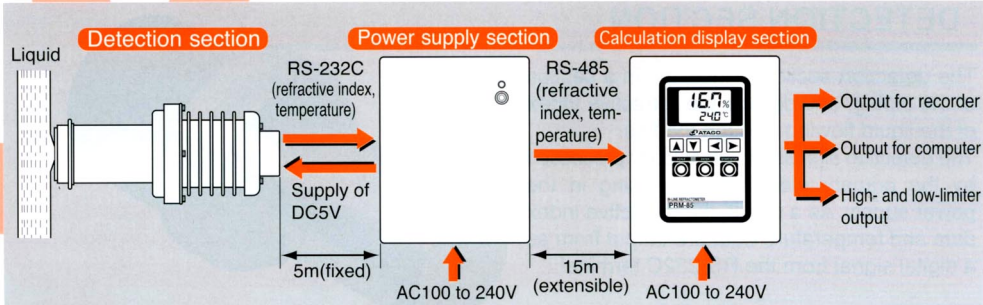

● Although the upper limit of the measurement temperature is 100°C, the liquid exceeding 100°C can be poured in the cleaning case. In this case, please beware of the following points:

*The power source must be turned off.

*The momentary difference between the sample liquid temperature and the cleaning liquid temperature must be kept at less than 80°C.

Samples to be taken into consideration for measurement

- Viscid substances (paste sample)
- Samples containing bubbles in large quantities
- Samples containing hard sludge or similar substances
- Samples with high fusing point (Solid sample at normal temperature)
- Samples which are likely to attach to the inside of piping
- Samples containing insoluble solids in large quantities
- Non-homogeneous samples containing on oil component or similar impurities

Usage environment of the PRM-85

- Use this instrument only in locations lower than 3,000 meters above sea level.
- Use it indoors.
- Use it at an ambient temperature from 5 to 40°C.
- Use this instrument in a location where the humidity is between 30%RH and 90%RH.
- Avoid locations with high temperature, such as in exposure to direct sunlight, or near heating equipment.
- Do not expose to extreme temperature fluctuations.
- Do not install in a location exposed to strong vibrations.
- Do not use in dusty locations.
- The PRM-85 cannot be used in locations which would require measures to protect it from explosion.

Dimensions

※Unit of length : mm

Detection Section

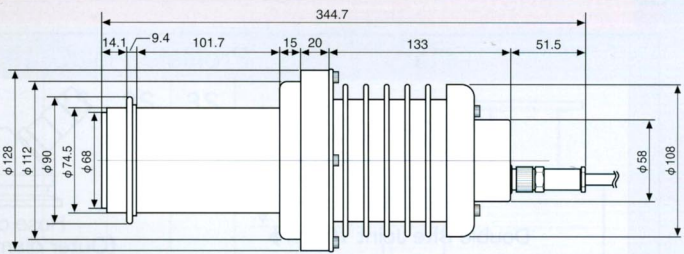
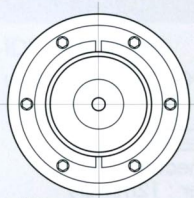

Weight : 4.3kg

Calculation Display Section

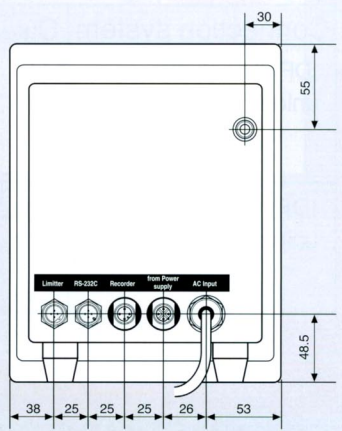
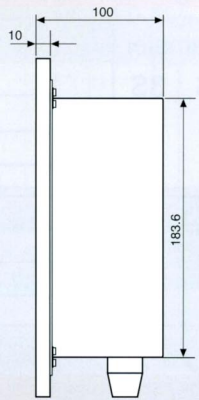
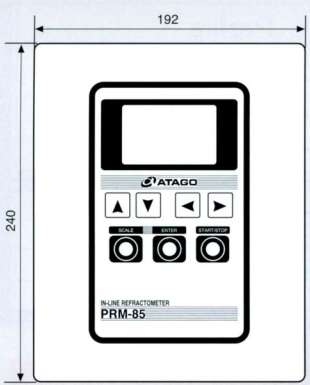

Weight : 3.3kg

Power Supply Section

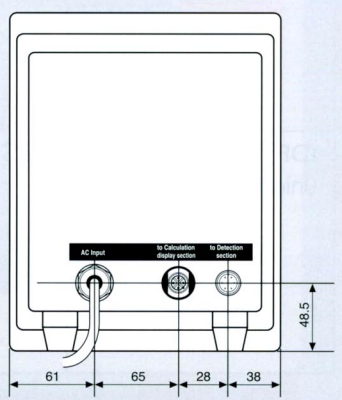
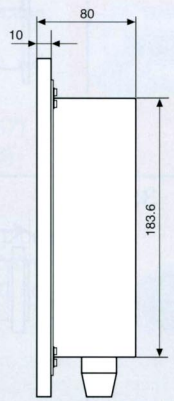
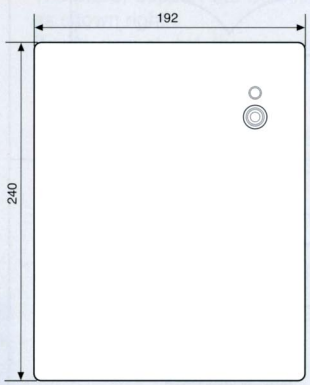

Weight : 3.1kg

List of sample inlet unit (Material : SUS 316)

Small diameter series

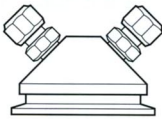
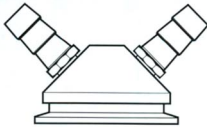
Profile	
	
Double Bite Joint 10mm ϕ	Hose connector (Outer diameter : 12mm ϕ)

Straight type

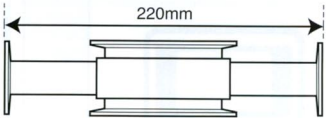
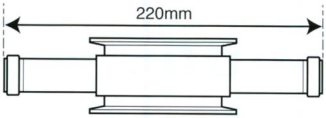
Connection system	Outer diameter			Profile
	1S	2S	3S	
IDF/ISO clamp union(ferrule)				
IDF/ISO screw union(screw)				

π type

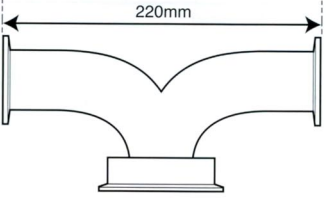
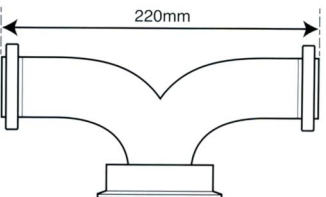
Connection system	Outer diameter		Profile
	2S	3S	
IDF/ISO clamp union(ferrule)			
IDF/ISO screw union(screw)			

L type

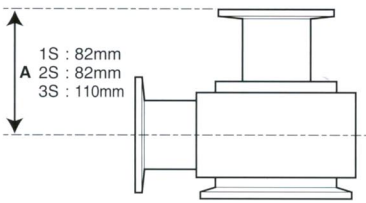
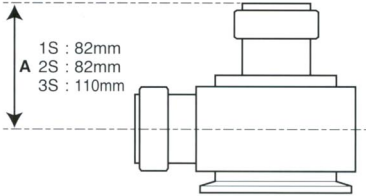
Connection system	Outer diameter			Profile
	1S	2S	3S	
IDF/ISO clamp union(ferrule)				 <p>1S : 82mm A 2S : 82mm 3S : 110mm</p>
IDF/ISO screw union(screw)				 <p>1S : 82mm A 2S : 82mm 3S : 110mm</p>

Inner diameter
1S : 23.0mm
2S : 47.8mm
3S : 72.3mm

*Please note that the size of piping is based on the IDF standard and the termination of piping is based on the ISO standard.

Support of the detection section

Since the detection section weighs 4.3kg, it may not be supported by connection with the sample inlet unit alone.

Therefore, support the detection section, as shown right.

If you cannot get the support, we will supply the following parts.

- 1) Pipe hanger(Part No.RE-67157)
- 2) Hanger pin(Part No.RE-67156)
- 3) Stand(Part No.RE-67155)

For the support bar, prepare a pipe having an outer diameter of 19.0mm and an inner diameter of 16.0 to 17.0mm.

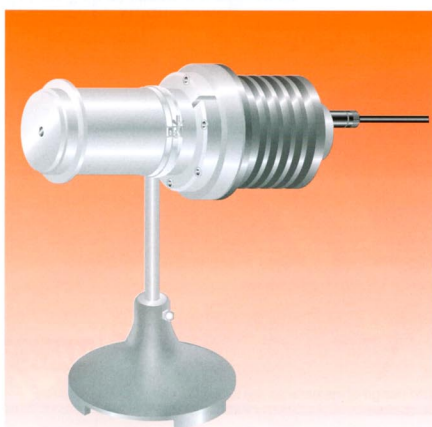

Specifications

Measurement items	: Either refractive index(nD), Brix(temperature compensation according to sucrose solution), or concentration (%) (temperature compensation according to samples), and temperature (°C)
Measurement range	: Refractive index (nD) 1.3220 to 1.5040, Brix 0.0 to 85.0%
Minimum indication	: Refractive index (nD) 0.0001, Brix or concentration 0.1%
Measurement accuracy	: Refractive index (nD) ± 0.0001 , Brix or concentration $\pm 0.1\%$
Measurement temperature	: 5 to 100°C(The liquid exceeding 100°C can be poured in the cleaning case. In this case, the power source must be turned off. And the momentary difference between the sample liquid temperature and the cleaning liquid temperature must be kept at less than 80°C.)
High and low limit settings	: High and low control limits can be set by the keys.
Display items	: Refractive index (nD), Brix, concentration (%), temperature (°C)
Display method	: LCD digital (Measurement values displayed by backlit characters 16 mm high)
Output items	: Either refractive index (nD), Brix or concentration (%), and temperature (°C)
Output method	: RS-232C, DC4 to 20mA
Alarm output	: Open-collector output for high and low limit settings (alarm output)
Power supply	: AC 100 to 240 V, 50/60Hz
Power consumption	: The detection section + power supply section : 12VA The calculation display section : 18VA
Connecting cables	: (A) Between the detection section and power supply section : 5 meters(fixed) (B) Between the power supply section and calculation display section : 15 meters(extensible)
Materials in contact with the solution	: Prism··· Artificial crystallization, Prism stage ··· SUS316
Light source	: LED (D line approximation)
Temperature sensor	: Thermistor
Operating temperature	: 5 to 40°C
Relative humidity	: 30 to 90%RH
Altitude (above sea level)	: Up to 3,000 m
Pressure resistance	: 1.0MPa(detection section)
Dimensions and weight	: Detection section : 29.3× ϕ 12.8cm, 4.3kg Calculation Display section : 19.2×10.0×24.0cm, 3.3kg Power supply : 19.2×8.0×24.0cm, 3.1kg



HACCP G.M.P. G.L.P.

ATAGO products are installed in HACCP, G.M.P. and G.L.P. systems.

*Specifications and design of appearance are subject to change without notice.

As of September, 2001

ATAGO CO.,LTD.

Main Office:32-10 Honcho, Itabashi-ku, Tokyo 173-0001, Japan
Phone:81-3-3964-6156 FAX:81-3-3964-6137
<http://www.atago.net/>
export@atago.net

