

## Standard Test Method for Foaming Properties of Surface-Active Agents<sup>1</sup>

This standard is issued under the fixed designation D 1173; the number immediately following the designation indicates the year of original adoption or, in the case of revision, the year of last revision. A number in parentheses indicates the year of last reapproval. A superscript epsilon ( $\epsilon$ ) indicates an editorial change since the last revision or reapproval.

### 1. Scope

1.1 This test method covers the determination of the foaming properties of surface-active agents as defined in Terminology D 459. This test method is applicable under limited and controlled conditions, but does not necessarily yield information correlating with specific end uses.

1.2 *This standard does not purport to address all of the safety concerns, if any, associated with its use. It is the responsibility of the user of this standard to establish appropriate safety and health practices and determine the applicability of regulatory limitations prior to use.*

### 2. Referenced Documents

#### 2.1 ASTM Standards:

D 459 Terminology Relating To Soaps and Other Detergents<sup>2</sup>

### 3. Apparatus

3.1 *Pipet*—The pipet (Fig. 1) shall be constructed from standard-wall, chemically resistant glass tubing having the following dimensions: for the bulb,  $45 \pm 1.5$  mm outside diameter; for the lower stem,  $7 \pm 0.5$  mm outside diameter. The upper stem shall be constructed to contain a solid-stopper, straight bore, No. 2, standard-taper stopcock having a 2-mm bore and stems 8 mm in outside diameter. Both the upper and lower seals of the bulb to the stems shall be hemispherical in shape. The lower stem shall be  $60 \pm 2$  mm in length from the point of attachment to the bulb and shall contain an orifice sealed into the lower end. The orifice shall be constructed from precision bore tubing having an inside diameter of  $2.9 \pm 0.02$  mm and a length of  $10 \pm 0.05$  mm, with both ends ground square. The orifice shall have an outside diameter so as to fit snugly into the lower stem and form a secure seal to the stem when heated with a sharp pointed flame in the blow torch. The pipet shall be calibrated to contain  $200 \pm 0.2$  mL at  $20^\circ\text{C}$ . The calibration mark shall be on the upper stem at least 15 mm below the barrel of the stopcock and shall completely encircle the stem.

3.2 *Receiver*—The receiver (Fig. 2) shall be constructed

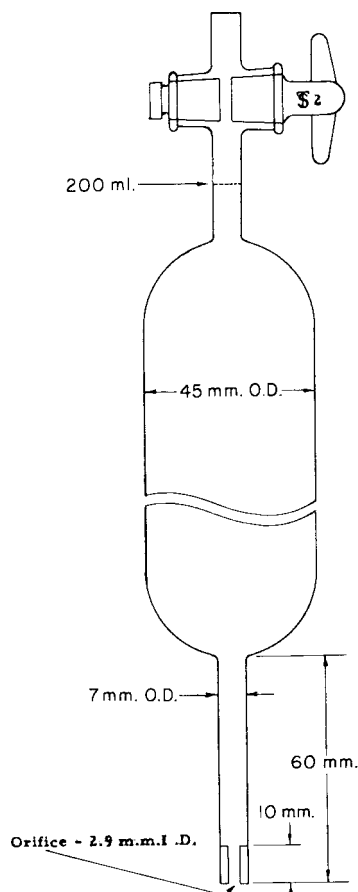

FIG. 1 Foam Pipet

from standard-wall, chemically resistant glass tubing having an internal diameter of  $50 \pm 0.8$  mm, with one end constricted and sealed to a straight-bore, solid-plug, standard-taper No. 6 stopcock having a 6-mm bore and 12-mm stems. The receiver shall have three calibration marks which shall completely encircle the tube. The first mark shall be at the 50-mL point, shall be measured with the stopcock closed, and shall not be on any curved portion of the constriction. The second mark shall be at the 250-mL point, and the third mark at a distance of  $90 \pm 0.5$  cm above the 50-mL mark. The receiver tube shall be mounted in a standard-wall tubular water jacket, having an external diameter of not less than 70 mm, fitted with inlet and outlet connections. The jacket may be attached to the receiver with rubber stoppers or may be sealed at the top and bottom.

<sup>1</sup> This test method is under the jurisdiction of ASTM Committee D12 on Soaps and Other Detergents and is the direct responsibility of Subcommittee D12.15 on Physical Testing.

Current edition approved Sept. 15, 1953. Published November 1953. Originally published as D 1173 – 51 T. Last previous edition D 1173 – 51 T.

<sup>2</sup> *Annual Book of ASTM Standards*, Vol 15.04.

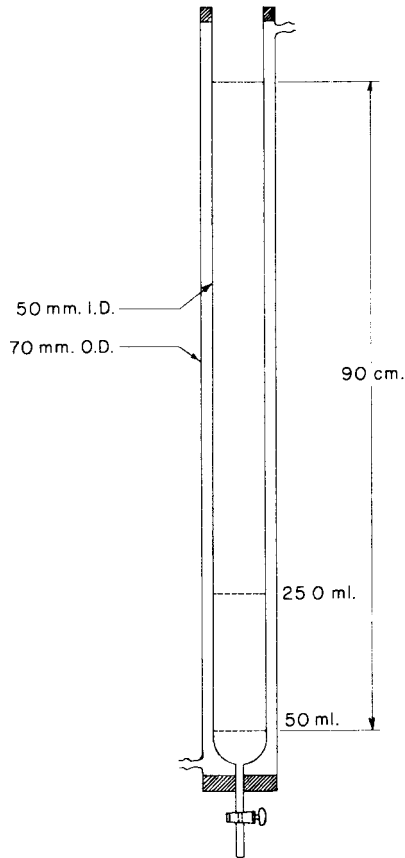

FIG. 2 Foam Receiver

The seal at the bottom shall be as close to the barrel of the stopcock as practicable. The assembled receiver and jacket shall be mounted securely in a plumb position and the jacket connected to a source of water thermostatically maintained at  $120 \pm 1^\circ\text{F}$  ( $49 \pm 0.5^\circ\text{C}$ ) for circulating through the jacket. At the top of the receiver there shall be a platform, flush with the top of the assembly, having a metal plate in which is drilled three indexing holes circumferentially placed around the receiver and having an angular displacement of  $120^\circ$  from each other. A clamp, which may be securely attached to the upper part of the pipet, shall fit into the holes. The clamp shall have three leveling screws and lock nuts and when properly mounted, shall exactly center the pipet in the receiver and bring the lower tip of the pipet level with the upper calibration mark

on the receiver. A meter stick shall be fastened to the side or behind the receiver with the zero point level with the 250-mL calibration point on the receiver.

#### 4. Test Solution

4.1 Distilled water, or water of various degrees of hardness, may be used for this test. Preheat the water used for preparing the solution and add slowly, while stirring vigorously, an amount of the surface-active agent that will produce the desired concentration. Continue stirring in such a manner as to avoid excessive foam formation, until solution of the surface-active agent is complete. Age the solution at a temperature of  $120^\circ\text{F}$  ( $49^\circ\text{C}$ ) for a total period of 30 min, counting the time when the surface-active agent is first added to the water.

#### 5. Procedure

5.1 While the surface-active solution is aging, circulate water at  $120^\circ\text{F}$  ( $49^\circ\text{C}$ ) through the water jacket of the receiver so as to bring it to the proper temperature. Rinse down the walls of the receiver with distilled water and, as an indication of cleanliness, observe whether the water drains down the walls in an unbroken film. At the completion of the aging period close the stopcock at the bottom of the receiver. Rinse the walls of the receiver with 50 mL of the solution, using a pipet, and, after draining to the bottom of the receiver, adjust the stopcock so that the level of the solution in the receiver is exactly at the 50-mL mark. Fill the pipet with the solution to the 200-mL mark, using a slight suction for the purpose. Immediately place it in position at the top of the receiver and open the stopcock. When all of the solution has run out of the pipet, start a stop watch, take a reading of the foam height and take a second reading at the end of 5 min. Take the reading by measuring the foam production at the top of the foam column at the highest average height to which the rim of the foam has reached. This height is proportional to the volume of air remaining in the foam.

#### 6. Report

6.1 In reporting results by this test, state the concentration in grams per liter, the temperature of the test, the degree of hardness of the water, and the initial foam height reading. It is desirable to conduct this test at a number of concentrations, the lowest of which shall be chosen to show a foam height which shall be no higher than 20 % of the foam height shown at the highest concentration.

*The American Society for Testing and Materials takes no position respecting the validity of any patent rights asserted in connection with any item mentioned in this standard. Users of this standard are expressly advised that determination of the validity of any such patent rights, and the risk of infringement of such rights, are entirely their own responsibility.*

*This standard is subject to revision at any time by the responsible technical committee and must be reviewed every five years and if not revised, either reapproved or withdrawn. Your comments are invited either for revision of this standard or for additional standards and should be addressed to ASTM Headquarters. Your comments will receive careful consideration at a meeting of the responsible technical committee, which you may attend. If you feel that your comments have not received a fair hearing you should make your views known to the ASTM Committee on Standards, at the address shown below.*

*This standard is copyrighted by ASTM, 100 Barr Harbor Drive, PO Box C700, West Conshohocken, PA 19428-2959, United States. Individual reprints (single or multiple copies) of this standard may be obtained by contacting ASTM at the above address or at 610-832-9585 (phone), 610-832-9555 (fax), or service@astm.org (e-mail); or through the ASTM website (www.astm.org).*