



Standard Test Methods for AC Loss Characteristics and Permittivity (Dielectric Constant) of Solid Electrical Insulation¹

This standard is issued under the fixed designation D 150; the number immediately following the designation indicates the year of original adoption or, in the case of revision, the year of last revision. A number in parentheses indicates the year of last reapproval. A superscript epsilon (ϵ) indicates an editorial change since the last revision or reapproval.

This standard has been approved for use by agencies of the Department of Defense.

1. Scope

1.1 These test methods cover the determination of relative permittivity, dissipation factor, loss index, power factor, phase angle, and loss angle of specimens of solid electrical insulating materials when the standards used are lumped impedances. The frequency range that can be covered extends from less than 1 Hz to several hundred megahertz.

NOTE 1—In common usage, the word relative is frequently dropped.

1.2 These test methods provide general information on a variety of electrodes, apparatus, and measurement techniques. The reader should also consult ASTM standards or other documents directly applicable to the material to be tested.^{2,3}

1.3 *This standard does not purport to address all of the safety concerns, if any, associated with its use. It is the responsibility of the user of this standard to establish appropriate safety and health practices and determine the applicability of regulatory limitations prior to use.* For specific hazard statements, see 7.2.6.1 and 10.2.1.

2. Referenced Documents

2.1 ASTM Standards:

- D 374 Test Methods for Thickness of Solid Electrical Insulation⁴
- D 618 Practice for Conditioning Plastics for Testing⁵
- D 1082 Test Method for Dissipation Factor and Permittivity (Dielectric Constant) of Mica⁴
- D 1531 Test Method for Relative Permittivity (Dielectric

Constant) and Dissipation Factor by Fluid Displacement Procedures⁶

D 1711 Terminology Relating to Electrical Insulation⁴

D 5032 Practice for Maintaining Constant Relative Humidity by Means of Aqueous Glycerin Solutions⁶

E 104 Practice for Maintaining Constant Relative Humidity by Means of Aqueous Solutions⁷

E 197 Specifications for Enclosures and Servicing Units for Tests Above and Below Room Temperature.⁸

3. Terminology

3.1 Definitions:

3.1.1 *capacitance, C, n*—that property of a system of conductors and dielectrics which permits the storage of electrically separated charges when potential differences exist between the conductors.

3.1.1.1 *Discussion*—Capacitance is the ratio of a quantity, q , of electricity to a potential difference, V . A capacitance value is always positive. The units are farads when the charge is expressed in coulombs and the potential in volts:

$$C = q/V \quad (1)$$

3.1.2 *dissipation factor, (D), (loss tangent), (tan δ), n*—the ratio of the loss index (κ'') to the relative permittivity (κ') which is equal to the tangent of its loss angle (δ) or the cotangent of its phase angle (θ) (see Fig. 1 and Fig. 2).

$$D = \kappa''/\kappa' \quad (2)$$

3.1.2.1 *Discussion*— a :

$$D = \tan \delta = \cot \theta = X_p/R_p = G/\omega C_p = 1/\omega C_p R_p \quad (3)$$

where:

G = equivalent ac conductance,

X_p = parallel reactance,

R_p = equivalent ac parallel resistance,

C_p = parallel capacitance, and

ω = $2\pi f$ (sinusoidal wave shape assumed).

The reciprocal of the dissipation factor is the quality factor, Q , sometimes called the storage factor. The dissipation factor,

¹ These test methods are under the jurisdiction of ASTM Committee D-9 on Electrical and Electronic Insulating Materials and are the direct responsibility of Subcommittee D09.12 on Electrical Tests.

Current edition approved Feb. 10, 1998. Published March 1999. Originally published as D 150 – 22 T. Last previous edition D 150 – 95.

² R. Bartnikas, Chapter 2, "Alternating-Current Loss and Permittivity Measurements", Engineering Dielectrics, Vol. IIB, Electrical Properties of Solid Insulating Materials, Measurement Techniques, R. Bartnikas, Editor, STP 926, ASTM, Philadelphia, 1987.

³ R. Bartnikas, Chapter 1, "Dielectric Loss in Solids", Engineering Dielectrics, Vol IIA, Electrical Properties of Solid Insulating Materials: Molecular Structure and Electrical Behavior, R. Bartnikas and R. M. Eichorn, Editors, STP 783, ASTM Philadelphia, 1983.

⁴ Annual Book of ASTM Standards, Vol 10.01.

⁵ Annual Book of ASTM Standards, Vol 08.01.

⁶ Annual Book of ASTM Standards, Vol 10.02.

⁷ Annual Book of ASTM Standards, Vol 11.03.

⁸ Discontinued, see 1980 Annual Book of ASTM Standards, Parts 40 and 41.

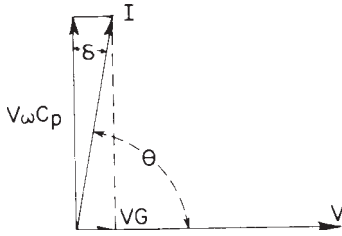

FIG. 1 Vector Diagram for Parallel Circuit

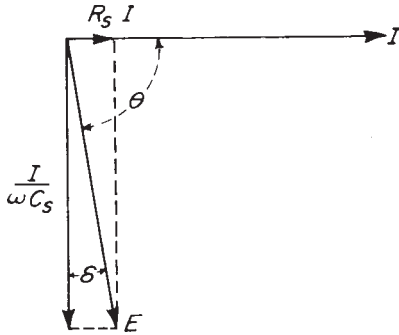

FIG. 2 Vector Diagram for Series Circuit

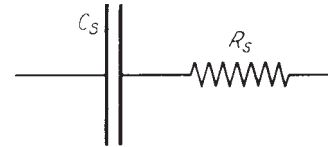

FIG. 4 Series Circuit

$$\kappa'' = \kappa' D$$

$$= \text{power loss}/(E^2 \times f \times \text{volume} \times \text{constant}) \quad (7)$$

When the power loss is in watts, the applied voltage is in volts per centimetre, the frequency is in hertz, the volume is the cubic centimetres to which the voltage is applied, the constant has the value of 5.556×10^{-13} .

3.1.4.2 Discussion—*b*—Loss index is the term agreed upon internationally. In the U.S.A. κ'' was formerly called the loss factor.

3.1.5 phase angle, θ , n —the angle whose cotangent is the dissipation factor, $\arccot \kappa''/\kappa'$ and is also the angular difference in the phase between the sinusoidal alternating voltage applied to a dielectric and the component of the resulting current having the same frequency as the voltage.

3.1.5.1 Discussion—*b*—The relation of phase angle and loss angle is shown in Fig. 1 and Fig. 2. Loss angle is sometimes called the phase defect angle.

3.1.6 power factor, *PF*, n —the ratio of the power in watts, *W*, dissipated in a material to the product of the effective sinusoidal voltage, *V*, and current, *I*, in volt-amperes.

3.1.6.1 Discussion—Power factor may be expressed as the cosine of the phase angle θ (or the sine of the loss angle δ).

$$PF = W/VI = G/\sqrt{G^2 + (\omega C_p)^2} = \sin \delta = \cos \theta \quad (8)$$

When the dissipation factor is less than 0.1, the power factor differs from the dissipation factor by less than 0.5 %. Their exact relationship may be found from the following:

$$PF = D/\sqrt{1 + D^2} \quad (9)$$

$$D = PF/\sqrt{1 - (PF)^2}$$

3.1.7 relative permittivity (relative dielectric constant) (*SIC*) $\kappa'(\epsilon_r)$, n —the real part of the relative complex permittivity. It is also the ratio of the equivalent parallel capacitance, C_p , of a given configuration of electrodes with a material as a dielectric to the capacitance, C_v , of the same configuration of electrodes with vacuum (or air for most practical purposes) as the dielectric:

$$\kappa' = C_p/C_v \quad (10)$$

3.1.7.1 Discussion—*a*—In common usage the word “relative” is frequently dropped.

3.1.7.2 Discussion—*b*—Experimentally, vacuum must be replaced by the material at all points where it makes a significant change in capacitance. The equivalent circuit of the dielectric is assumed to consist of C_p , a capacitance in parallel with conductance. (See Fig. 3.)

3.1.7.3 Discussion—*c*— C_x is taken to be C_p , the equivalent parallel capacitance as shown in Fig. 3.

3.1.7.4 Discussion—*d*—The series capacitance is larger than the parallel capacitance by less than 1 % for a dissipation

D, of the capacitor is the same for both the series and parallel representations as follows:

$$D = \omega R_s C_s = 1/\omega R_p C_p \quad (4)$$

The relationships between series and parallel components are as follows:

$$C_p = C_s/(1 + D^2) \quad (5)$$

$$R_p/R_s = (1 + D^2)/D^2 = 1 + (1/D^2) = 1 + Q^2 \quad (6)$$

3.1.2.2 Discussion—*b*: Series Representation—While the parallel representation of an insulating material having a dielectric loss (Fig. 3) is usually the proper representation, it is always possible and occasionally desirable to represent a capacitor at a single frequency by a capacitance, C_s , in series with a resistance, R_s (Fig. 4 and Fig. 2).

3.1.3 loss angle (phase defect angle), δ , n —the angle whose tangent is the dissipation factor or $\arctan \kappa''/\kappa'$ or whose cotangent is the phase angle.

3.1.3.1 Discussion—The relation of phase angle and loss angle is shown in Fig. 1 and Fig. 2. Loss angle is sometimes called the phase defect angle.

3.1.4 loss index, $\kappa''(\epsilon_r)$, n —the magnitude of the imaginary part of the relative complex permittivity; it is the product of the relative permittivity and dissipation factor.

3.1.4.1 Discussion—*a*—It may be expressed as:

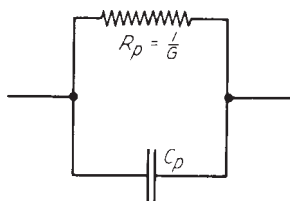

FIG. 3 Parallel Circuit

factor of 0.1, and by less than 0.1 % for a dissipation factor of 0.03. If a measuring circuit yields results in terms of series components, the parallel capacitance must be calculated from Eq 5 before the corrections and permittivity are calculated.

3.1.7.5 *Discussion—e*—The permittivity of dry air at 23°C and standard pressure at 101.3 kPa is 1.000536 (1).⁹ Its divergence from unity, $\kappa' - 1$, is inversely proportional to absolute temperature and directly proportional to atmospheric pressure. The increase in permittivity when the space is saturated with water vapor at 23°C is 0.00025 (2, 3), and varies approximately linearly with temperature expressed in degrees Celsius, from 10 to 27°C. For partial saturation the increase is proportional to the relative humidity

3.2 Other definitions may be found in Terminology D 1711.

4. Summary of Test Method

4.1 Capacitance and ac resistance measurements are made on a specimen. Relative permittivity is the specimen capacitance divided by a calculated value for the vacuum capacitance (for the same electrode configuration), and is significantly dependent on resolution of error sources. Dissipation factor, generally independent of the specimen geometry, is also calculated from the measured values.

4.2 This method provides (a) guidance for choices of electrodes, apparatus, and measurement approaches; and (b) directions on how to avoid or correct for capacitance errors.

4.2.1 General Measurement Considerations:

Fringing and Stray Capacitance	Guarded Electrodes
Geometry of Specimens	Calculation of Vacuum Capacitance
Edge, Ground, and Gap Corrections	

4.2.2 Electrode Systems - Contacting Electrodes

Electrode Materials	Metal Foil
Conducting Paint	Fired-On Silver
Sprayed Metal	Evaporated Metal
Liquid Metal	Rigid Metal
Water	

4.2.3 Electrode Systems - Non-Contacting Electrodes

Fixed Electrodes	Micrometer Electrodes
Fluid Displacement Methods	

4.2.4 Choice of Apparatus and Methods for Measuring Capacitance and A-C Loss

Frequency	Direct and Substitution Methods
Two-Terminal Measurements	Three-Terminal Measurements
Fluid Displacement Methods	Accuracy considerations

5. Significance and Use

5.1 *Permittivity*—Insulating materials are used in general in two distinct ways, (1) to support and insulate components of an electrical network from each other and from ground, and (2) to function as the dielectric of a capacitor. For the first use, it is generally desirable to have the capacitance of the support as small as possible, consistent with acceptable mechanical, chemical, and heat-resisting properties. A low value of permittivity is thus desirable. For the second use, it is desirable to have a high value of permittivity, so that the capacitor may be physically as small as possible. Intermediate values of permit-

tivity are sometimes used for grading stresses at the edge or end of a conductor to minimize ac corona. Factors affecting permittivity are discussed in Appendix X3.

5.2 *AC Loss*—For both cases (as electrical insulation and as capacitor dielectric) the ac loss generally should be small, both in order to reduce the heating of the material and to minimize its effect on the rest of the network. In high frequency applications, a low value of loss index is particularly desirable, since for a given value of loss index, the dielectric loss increases directly with frequency. In certain dielectric configurations such as are used in terminating bushings and cables for test, an increased loss, usually obtained from increased conductivity, is sometimes introduced to control the voltage gradient. In comparisons of materials having approximately the same permittivity or in the use of any material under such conditions that its permittivity remains essentially constant, the quantity considered may also be dissipation factor, power factor, phase angle, or loss angle. Factors affecting ac loss are discussed in Appendix X3.

5.3 *Correlation*—When adequate correlating data are available, dissipation factor or power factor may be used to indicate the characteristics of a material in other respects such as dielectric breakdown, moisture content, degree of cure, and deterioration from any cause. However, deterioration due to thermal aging may not affect dissipation factor unless the material is subsequently exposed to moisture. While the initial value of dissipation factor is important, the change in dissipation factor with aging may be much more significant.

6. General Measurement Considerations

6.1 *Fringing and Stray Capacitance*— These test methods are based upon measuring the specimen capacitance between electrodes, and measuring or calculating the vacuum capacitance (or air capacitance for most practical purposes) in the same electrode system. For unguarded two-electrode measurements, the determination of these two values required to compute the permittivity, κ_x' is complicated by the presence of undesired fringing and stray capacitances which get included in the measurement readings. Fringing and stray capacitances are illustrated by Figs. 5 and 6 for the case of two unguarded parallel plate electrodes between which the specimen is to be placed for measurement. In addition to the desired direct interelectrode capacitance, C_v , the system as seen at terminals a-a' includes the following:

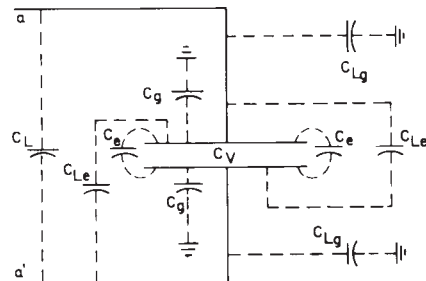

FIG. 5 Stray Capacitance, Unguarded Electrodes

⁹ The boldface numbers in parentheses refer to the list of references appended to these test methods.

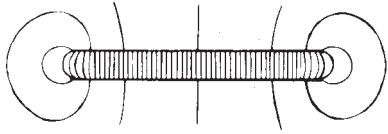

FIG. 6 Flux Lines Between Unguarded Electrodes

- C_e = fringing or edge capacitance,
- C_g = capacitance to ground of the outside face of each electrode,
- C_L = capacitance between connecting leads,
- C_{Lg} = capacitance of the leads to ground, and
- C_{Le} = capacitance between the leads and the electrodes.

Only the desired capacitance, C_v , is independent of the outside environment, all the others being dependent to a degree on the proximity of other objects. It is necessary to distinguish between two possible measuring conditions to determine the effects of the undesired capacitances. When one measuring electrode is grounded, as is often the case, all of the capacitances described are in parallel with the desired C_v with the

exception of the ground capacitance of the grounded electrode and its lead. If C_v is placed within a chamber with walls at guard potential, and the leads to the chamber are guarded, the capacitance to ground no longer appears, and the capacitance seen at a-a' includes C_v and C_e only. For a given electrode arrangement, the edge capacitance, C_e , can be calculated with reasonable accuracy when the dielectric is air. When a specimen is placed between the electrodes, the value of the edge capacitance can change - requiring the use of an edge capacitance correction using the information from Table 1. Empirical corrections have been derived for various conditions, and these are given in Table 1 (for the case of thin electrodes such as foil). In routine work, where best accuracy is not required it may be convenient to use unshielded, two-electrode systems and make the approximate corrections. Since area (and hence C_v) increases of the square diameter while perimeter (and hence C_e) increases linearly with diameter, the percentage error in permittivity due to neglecting the edge correction decreases with increasing specimen diameter. However, for exacting measurements it is necessary to use guarded electrodes.

TABLE 1 Calculations of Vacuum Capacitance and Edge Corrections (see 8.5)

NOTE 1—See Table 2 for Identification of Symbols used.

Type of Electrode	Direct Inter-Electrode Capacitance in Vacuum, pF	Correction for Stray Field at an Edge, pF
Disk electrodes with guard-ring: 	$C_v = \epsilon_0 \frac{A}{t} =$ $0.0088542 \frac{A}{t}$ $A = \frac{\pi}{4} (d_1 + B^A g)^2$	$C_e = 0$
Disk electrodes without guard-ring: Diameter of the electrodes = diameter of the specimen: 		where $a \ll t$, $C_e = (0.0087 - 0.00252 \ln t)P$
Equal electrodes smaller than the specimen: 	$C_v = 0.0069541 \frac{d_1^2}{t}$	$C_e = (0.0019 \kappa_x' - 0.00252 \ln t + 0.0068)P$ where: κ_x' = an approximate value of the specimen permittivity, and $a \ll t$.
Unequal electrodes: 		$C_e = (0.0041 \kappa_x' - 0.00334 \ln t + 0.0122)P$ where: κ_x' = an approximate value of the specimen permittivity, and $a \ll t$.
Cylindrical electrodes with guard-ring: 	$C_v = \frac{0.055632 (l_1 + B^A g)}{\ln \frac{d_2}{d_1}}$	$C_e = 0$
Cylindrical electrodes without guard-ring: 	$C_v = \frac{0.055632 l_1}{\ln \frac{d_2}{d_1}}$	$C_e = (0.0038 \kappa_x' - 0.00504 \ln t + 0.0136)P$ where κ_x' = an approximate value of the specimen permittivity. $P = \pi (d_1 + t)$ If $\frac{t}{t + d_1} < \frac{1}{10}$

^ASee Appendix X2 for corrections to guard gap.

TABLE 2 Calculation of Permittivity and Dissipation Factor, Noncontacting Electrodes

Permittivity	Dissipation Factor	Identification of Symbols
<p>Micrometer electrodes in air (with guard ring):</p> $\kappa_x' = \frac{1}{1 - \frac{\Delta C t_0}{C_1 t}}$ <p>or, if t_0 is adjusted to a new value, t_0', such that $\Delta C = 0$</p> $\kappa_x' = \frac{t}{t - (t_0 - t_0')}$		
<p>Plane electrodes—fluid displacement:</p> $\kappa_x' = \frac{\kappa_f'}{1 + D_x^2} \cdot \left[\frac{(C_f + \Delta C)(1 + D_c^2)}{C_f + M[C_f - (C_f + \Delta C)(1 + D_c^2)]} \right]$ <p>When the dissipation factor of the specimen is less than about 0.1, the following equations can be used:</p> $\kappa_x' = \frac{\kappa_f' \frac{\Delta C}{C_f} \frac{t_0}{t}}{1 - \frac{\kappa_f' \Delta C}{C_f} \frac{t_0}{t}}$		
<p>CYLINDRICAL ELECTRODES (WITH GUARD RINGS)—FLUID DISPLACEMENT.</p> $\kappa_x' = \frac{\kappa_f'}{1 - \frac{\Delta C}{C_1} \log \frac{d_3/d_0}{d_2/d_1}}$ $D_x = D_c + \Delta D \frac{\kappa_x'}{\kappa_f'} \left\{ \log \frac{d_3}{d_0} - 1 \right\}$		
<p>Two-fluid method—plane electrodes (with guard ring):</p> $(D_x^2 + 1) \kappa_x' = \kappa_{f1}' + \frac{\Delta C_1 C_2 [(D_{f2}^2 + 1) \kappa_{f2}' - \kappa_{f1}']}{\Delta C_1 C_2 - \Delta C_2 C_1}$ $D_x = (D_x^2 + 1) \kappa_x' \left[\frac{\epsilon_0 A_2}{t_x} \left(\frac{D_{c2}}{C_2} - \frac{D_{f2}}{C_{f2}} \right) + \frac{D_{f2}}{\kappa_{f2}'} \right]$ $t_x = \frac{[C_2 C_{f2} \Delta C_1 - C_1 C_{f1} \Delta C_2] (D_{f2}^2 + 1) \epsilon_0 A_2 \kappa_{f1}' \kappa_{f2}'}{[\kappa_{f2}' (D_{f2}^2 + 1) - \kappa_{f1}'] C_1 C_2 C_{f1} C_{f2}}$		

ΔC = capacitance change when specimen is inserted (+ when capacitance increases),
 C_1 = capacitance with specimen in place,
 ΔD = increase in dissipation factor when specimen is inserted,
 D_c = dissipation factor with specimen in place.
 D_f = dissipation factor, fluid,
 t_0 = parallel-plate spacing mm,
 t = average thickness of specimen mm,
 M = $t_0/t - 1$,
 C_f = $\kappa_f' C_v$, capacitance with fluid alone,
 ϵ_0 = permittivity of a vacuum (0.0088542 pF/mm),
 A = area of the electrodes, mm² (the smaller if the two are unequal),
 κ_f' = permittivity of fluid at test temperature (= 1.00066 for air at 23°C, 50 % RH),
 C_v = vacuum capacitance of area considered ($\epsilon_0 A/t_0$, pF),
 d_0 = OD of inner electrode,
 d_1 = ID of specimen,
 d_2 = OD of specimen, and
 d_3 = ID of outer electrode
 g = guard gap, mm
 $d_{1,2, \text{ or } 3}$ = diameter, mm (see sketches)
 C_v = Vacuum capacitance
 B = $1 - 2\delta$ (see Appendix X2.1.3)
 (ed. note: ALSO eliminate the "''" after B (two places) and the footnote reference to Appendix X2).
 C_e = edge capacitance
 \ln = natural logarithm
 κ_x' = specimen permittivity (approximate value for Table 1 calculations)
 p = perimeter of measuring (low voltage) electrode, mm
 l = length of measuring (low voltage) electrode, mm
 NOTE— C and D in these equations are the values for the cell and may require calculations from the readings of the measuring circuit (as when using parallel substitution). Refer to Note 3.
 NOTE—In the equation for the two-fluid method, subscripts 1 and 2 refer to the first and second fluids, respectively.
 NOTE—Values of C in the two-fluid equations are the equivalent series values.
 A_2 = effective area of guarded electrode with specimen in liquid, = $(d + B_g)^2 \pi/4$ (See Appendix X2 for corrections to guard gap).

6.2 Guarded Electrodes—The fringing and stray capacitance at the edge of the guarded electrode is practically eliminated by the addition of a guard electrode as shown in Fig. 7 and Fig. 8. If the test specimen and guard electrode extend beyond the guarded electrode by at least twice the thickness of the specimen and the guard gap is very small, the field

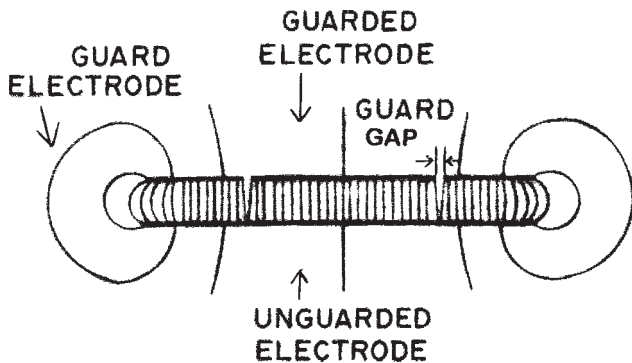

FIG. 7 Flux Lines Between Guarded Parallel Plate Electrodes

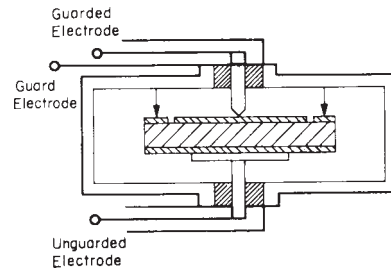

FIG. 8 Three-Terminal Cell for Solids

distribution in the guarded area will be identical with that existing when vacuum is the dielectric, and the ratio of these two direct capacitances is the permittivity. Furthermore, the field between the active electrodes is defined and the vacuum capacitance can be calculated with the accuracy limited only by the accuracy with which the dimensions are known. For these reasons the guarded electrode (three-terminal) method is to be used as the referee method unless otherwise agreed upon. Fig. 8 shows a schematic representation of a completely guarded

and shielded electrode system. Although the guard is commonly grounded, the arrangement shown permits grounding either measuring electrode or none of the electrodes to accommodate the particular three-terminal measuring system being used. If the guard is connected to ground, or to a guard terminal on the measuring circuit, the measured capacitance is the direct capacitance between the two measuring electrodes. If, however, one of the measuring electrodes is grounded, the capacitance to ground of the ungrounded electrode and leads is in parallel with the desired direct capacitance. To eliminate this source of error, the ungrounded electrode should be surrounded by a shield connected to guard as shown in Fig. 8. In addition to guarded methods, which are not always convenient or practical and which are limited to frequencies less than a few megahertz, techniques using special cells and procedures have been devised that yield, with two-terminal measurements, accuracies comparable to those obtained with guarded measurements. Such methods described here include shielded micrometer electrodes (7.3.2) and fluid displacement methods (7.3.3).

6.3 Geometry of Specimens—For determining the permittivity and dissipation factor of a material, sheet specimens are preferable. Cylindrical specimens can also be used, but generally with lesser accuracy. The source of the greatest uncertainty in permittivity is in the determination of the dimensions of the specimen, and particularly that of its thickness which should, therefore, be large enough to allow its measurement with the required accuracy. The chosen thickness will depend on the method of producing the specimen and the likely variation from point to point. For 1 % accuracy a thickness of 1.5 mm (0.06 in.) is usually sufficient, although for greater accuracy it may be desirable to use a thicker specimen. Another source of error, when foil or rigid electrodes are used, is in the unavoidable gap between the electrodes and the specimen. For thin specimens the error in permittivity can be as much as 25 %. A similar error occurs in dissipation factor, although when foil electrodes are applied with a grease, the two errors may not have the same magnitude. For the most accurate measurements on thin specimens, the fluid displacement method should be used (6.3.3). This method reduces or completely eliminates the need for electrodes on the specimen. The thickness must be determined by measurements distributed systematically over the area of the specimen that is used in the electrical measurement and should be uniform within $\pm 1\%$ of the average thickness. If the whole area of the specimen will be covered by the electrodes, and if the density of the material is known, the average thickness can be determined by weighing. The diameter chosen for the specimen should be such as to provide a specimen capacitance that can be measured to the desired accuracy. With well guarded and screened apparatus there need be no difficulty in measuring specimens having capacitances of 10 pF to a resolution of 1 part in 1000. A thick specimen of low permittivity may necessitate a diameter of 100 mm or more to obtain the desired capacitance accuracy. In the measurement of small values of dissipation factor, the essential points are that no appreciable dissipation factor shall be contributed by the series resistance of the electrodes and that in the measuring network no large capacitance shall be connected in parallel

with that of the specimen. The first of these points favors thick specimens; the second suggests thin specimens of large area. Micrometer electrode methods (6.3.2) can be used to eliminate the effects of series resistance. A guarded specimen holder (Fig. 8) can be used to minimize extraneous capacitances.

6.4 Calculation of Vacuum Capacitance—The practical shapes for which capacitance can be most accurately calculated are flat parallel plates and coaxial cylinders, the equations for which are given in Table 1. These equations are based on a uniform field between the measuring electrodes, with no fringing at the edges. Capacitance calculated on this basis is known as the direct interelectrode capacitance.

6.5 Edge, Ground, and Gap Corrections—The equations for calculating edge capacitance, given in Table 1, are empirical, based on published work (4) (see 8.5). They are expressed in terms of picofarads per centimetre of perimeter and are thus independent of the shape of the electrodes. It is recognized that they are dimensionally incorrect, but they are found to give better approximations to the true edge capacitance than any other equations that have been proposed. Ground capacitance cannot be calculated by any equations presently known. When measurements must be made that include capacitance to ground, it is recommended that the value be determined experimentally for the particular setup used. The difference between the capacitance measured in the two-terminal arrangement and the capacitance calculated from the permittivity and the dimensions of the specimen is the ground capacitance plus the edge capacitance. The edge capacitance can be calculated using one of the equations of Table 1. As long as the same physical arrangement of leads and electrodes is maintained, the ground capacitance will remain constant, and the experimentally determined value can be used as a correction to subsequently measured values of capacitance. The effective area of a guarded electrode is greater than its actual area by approximately half the area of the guard gap (5, 6, 18). Thus, the diameter of a circular electrode, each dimension of a rectangular electrode, or the length of a cylindrical electrode is increased by the width of this gap. When the ratio of gap width, g , to specimen thickness, t , is appreciable, the increase in the effective dimension of the guarded electrode is somewhat less than the gap width. Details of computation for this case are given in Appendix X2.

7. Electrode Systems ¹⁰

7.1 Contacting Electrodes—A specimen may be provided with its own electrodes, of one of the materials listed below. For two-terminal measurements the electrodes may extend either to the edge of the specimen or may be smaller than the specimen. In the latter case the two electrodes may be equal or unequal in size. If equal in size and smaller than the specimen, the edge of the specimen must extend beyond the electrodes by at least twice the specimen thickness. The choice between these three sizes of electrodes will depend on convenience of application of the electrodes, and on the type of measurement adopted. The edge correction (see Table 1) is smallest for the

¹⁰ Additional information on electrode systems can be found in Research Report RR: D09-1037 available from ASTM Headquarters.

case of electrodes extending to the edge of the specimen and largest for unequal electrodes. When the electrodes extend to the edge of the specimen, these edges must be sharp. Such electrodes must be used, if attached electrodes are used at all, when a micrometer electrode system is employed. When equal-size electrodes smaller than the specimen are used, it is difficult to center them unless the specimen is translucent or an aligning fixture is employed. For three-terminal measurements, the width of the guard electrode shall be at least twice the thickness of the specimen (6, 7). The gap width shall be as small as practical (0.5 mm is possible). For measurement of dissipation factor at the higher frequencies, electrodes of this type may be unsatisfactory because of their series resistance. Micrometer electrodes should be used for the measurements.

7.2 Electrode Materials:

7.2.1 Metal Foil—Lead or tin foil from 0.0075 to 0.025 mm thick applied with a minimum quantity of refined petrolatum, silicone grease, silicone oil, or other suitable low-loss adhesive is generally used as the electrode material. Aluminum foil has also been used, but it is not recommended because of its stiffness and the probability of high contact resistance due to the oxidized surface. Lead foil also may give trouble because of its stiffness. Such electrodes should be applied under a smoothing pressure sufficient to eliminate all wrinkles and to work excess adhesive toward the edge of the foil. One very effective method is to use a narrow roller, and to roll outward on the surface until no visible imprint can be made on the foil. With care the adhesive film can be reduced to 0.0025 mm. As this film is in series with the specimen, it will always cause the measured permittivity to be too low and probably the dissipation factor to be too high. These errors usually become excessive for specimens of thickness less than 0.125 mm. The error in dissipation factor is negligible for such thin specimens only when the dissipation factor of the film is nearly the same as that of the specimen. When the electrode is to extend to the edge, it should be made larger than the specimen and then cut to the edge with a small, finely ground blade. A guarded and guard electrode can be made from an electrode that covers the entire surface, by cutting out a narrow strip (0.5 mm is possible) by means of a compass equipped with a narrow cutting edge.

7.2.2 Conducting Paint—Certain types of high-conductivity silver paints, either air-drying or low-temperature-baking varieties, are commercially available for use as electrode material. They are sufficiently porous to permit diffusion of moisture through them and thereby allow the test specimen to condition after application of the electrodes. This is particularly useful in studying humidity effects. The paint has the disadvantage of not being ready for use immediately after application. It usually requires an overnight air-drying or low-temperature baking to remove all traces of solvent, which otherwise may increase both permittivity and dissipation factor. It also may not be easy to obtain sharply defined electrode areas when the paint is brushed on, but this limitation usually can be overcome by spraying the paint and employing either clamp-on or pressure-sensitive masks. The conductivity of silver paint electrodes may be low enough to give trouble at the

higher frequencies. It is essential that the solvent of the paint does not affect the specimen permanently.

7.2.3 Fired-On Silver—Fired-on silver electrodes are suitable only for glass and other ceramics that can withstand, without change, a firing temperature of about 350°C. Its high conductivity makes such an electrode material satisfactory for use on low-loss materials such as fused silica, even at the highest frequencies, and its ability to conform to a rough surface makes it satisfactory for use with high-permittivity materials, such as the titanates.

7.2.4 Sprayed Metal—A low-melting-point metal applied with a spray gun provides a spongy film for use as electrode material which, because of its grainy structure, has roughly the same electrical conductivity and the same moisture porosity as conducting paints. Suitable masks must be used to obtain sharp edges. It conforms readily to a rough surface, such as cloth, but does not penetrate very small holes in a thin film and produce short circuits. Its adhesion to some surfaces is poor, especially after exposure to high humidity or water immersion. Advantages over conducting paint are freedom from effects of solvents, and readiness for use immediately after application.

7.2.5 Evaporated Metal—Evaporated metal used as an electrode material may have inadequate conductivity because of its extreme thinness, and must be backed with electroplated copper or sheet metal. Its adhesion is adequate, and by itself it is sufficiently porous to moisture. The necessity for using a vacuum system in evaporating the metal is a disadvantage.

7.2.6 Liquid Metal—Mercury electrodes may be used by floating the specimen on a pool of mercury and using confining rings with sharp edges for retaining the mercury for the guarded and guard electrodes, as shown in Fig. 9. A more convenient arrangement, when a considerable number of specimens must be tested, is the test fixture shown in Fig. 4 of Test Method D 1082. There is some health hazard present due to the toxicity of mercury vapor, especially at elevated temperatures, and suitable precautions should be taken during use. In measuring low-loss materials in the form of thin films such as mica splittings, contamination of the mercury may introduce considerable error, and it may be necessary to use clean mercury for each test. Wood's metal or other low-melting alloy can be used in a similar manner with a somewhat reduced health hazard.

7.2.6.1 Warning— *Mercury metal-vapor poisoning has long been recognized as a hazard in the industry. The exposure limits are set by government agencies and are usually based upon recommendations made by the American Conference of Governmental Industrial Hygienists.¹¹ The concentration of mercury vapor over spills from broken thermometers, barometers, and other instruments using mercury can easily exceed*

¹¹ American Conference of Governmental Hygienists, Building D-7, 6500 Glenway Ave., Cincinnati, OH 45211.

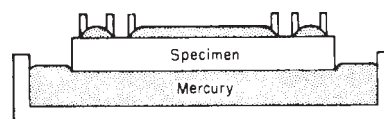

FIG. 9 Guarded Specimen with Mercury Electrodes

these exposure limits. Mercury, being a liquid with high surface tension and quite heavy, will disperse into small droplets and seep into cracks and crevices in the floor. This increased area of exposure adds significantly to the mercury vapor concentration in the air. The use of a commercially available emergency spill kit is recommended whenever a spill occurs. Mercury vapor concentration is easily monitored using commercially available sniffers. Make spot checks periodically around operations where mercury is exposed to the atmosphere. Make thorough checks after spills.

7.2.7 Rigid Metal—For smooth, thick, or slightly compressible specimens, rigid electrodes under high pressure can sometimes be used, especially for routine work. Electrodes 10 mm in diameter, under a pressure of 18.0 MPa have been found useful for measurements on plastic materials, even those as thin as 0.025 mm. Electrodes 50 mm in diameter, under pressure, have also been used successfully for thicker materials. However, it is difficult to avoid an air film when using solid electrodes, and the effect of such a film becomes greater as the permittivity of the material being tested increases and its thickness decreases. The uncertainty in the determination of thickness also increases as the thickness decreases. The dimensions of a specimen may continue to change for as long as 24 h after the application of pressure.

7.2.8 Water—Water can be used as one electrode for testing insulated wire and cable when the measurements are made at low frequency (up to 1000 Hz, approximately). Care must be taken to ensure that electrical leakage at the ends of the specimen is negligible.

7.3 Non-Contacting Electrodes:

7.3.1 Fixed Electrodes—Specimens of sufficiently low surface conductivity can be measured without applied electrodes by inserting them in a prefabricated electrode system, in which there is an intentional airgap on one or both sides of the specimen. The electrode system should be rigidly assembled and should preferably include a guard electrode. For the same accuracy, a more accurate determination of the electrode spacing and the thickness of the specimen is required than if direct contact electrodes are used. However, if the electrode system is filled with a liquid, these limitations may be removed (see 7.3.3).

7.3.2 Micrometer Electrodes—The micrometer-electrode system, as shown in Fig. 10, was developed (8) to eliminate the errors caused by the series inductance and resistance of the

connecting leads and of the measuring capacitor at high frequencies. A built-in vernier capacitor is also provided for use in the susceptance variation method. It accomplishes this by maintaining these inductances and resistances relatively constant, regardless of whether the test specimen is in or out of the circuit. The specimen, which is either the same size as, or smaller than, the electrodes, is clamped between the electrodes. Unless the surfaces of the specimen are lapped or ground very flat, metal foil or its equivalent must be applied to the specimen before it is placed in the electrode system. If electrodes are applied, they also must be smooth and flat. Upon removal of the specimen, the electrode system can be made to have the same capacitance by moving the micrometer electrodes closer together. When the micrometer-electrode system is carefully calibrated for capacitance changes, its use eliminates the corrections for edge capacitance, ground capacitance, and connection capacitance. In this respect it is advantageous to use it over the entire frequency range. A disadvantage is that the capacitance calibration is not as accurate as that of a conventional multiplate variable capacitor, and also it is not direct reading. At frequencies below 1 MHz, where the effect of series inductance and resistance in the leads is negligible, the capacitance calibration of the micrometer electrodes can be replaced by that of a standard capacitor, either in parallel with the micrometer-electrode system or in the adjacent capacitance arm of the bridge. The change in capacitance with the specimen in and out is measured in terms of this capacitor. A source of minor error in a micrometer-electrode system is that the edge capacitance of the electrodes, which is included in their calibration, is slightly changed by the presence of a dielectric having the same diameter as the electrodes. This error can be practically eliminated by making the diameter of the specimen less than that of the electrodes by twice its thickness (3). When no electrodes are attached to the specimen, surface conductivity may cause serious errors in dissipation factor measurements of low loss material. When the bridge used for measurement has a guard circuit, it is advantageous to use guarded micrometer electrodes. The effects of fringing, etc., are almost completely eliminated. When the electrodes and holder are well made, no capacitance calibration is necessary as the capacitance can be calculated from the electrode spacing and the diameter. The micrometer itself will require calibration, however. It is not practicable to use electrodes on the specimen when using guarded micrometer electrodes unless the specimen is smaller in diameter than the guarded electrode.

7.3.3 Fluid Displacement Methods—When the immersion medium is a liquid, and no guard is used, the parallel-plate system preferably shall be constructed so that the insulated high potential plate is supported between, parallel to, and equidistant from two parallel low-potential or grounded plates, the latter being the opposite inside walls of the test cell designed to hold the liquid. This construction makes the electrode system essentially self-shielding, but normally requires duplicate test specimens. Provision must be made for precise temperature measurement of the liquid (9, 10). Cells should be constructed of brass and gold plated. The high-potential electrode shall be removable for cleaning. The faces must be as nearly optically flat and plane parallel as possible.

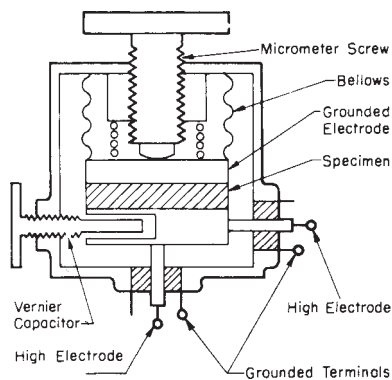

FIG. 10 Micrometer-Electrode System

A suitable liquid cell for measurements up to 1 MHz is shown in Fig. 4 of Test Method D 1531. Changes in the dimensions of this cell may be made to provide for testing sheet specimens of various thicknesses or sizes, but, such changes should not reduce the capacitance of the cell filled with the standard liquid to less than 100 pF. For measurements at frequencies from 1 to about 50 MHz, the cell dimensions must be greatly reduced, and the leads must be as short and direct as possible. The capacitance of the cell with liquid shall not exceed 30 or 40 pF for measurements at 50 MHz. Experience has shown that a capacitance of 10 pF can be used up to 100 MHz without loss of accuracy. Guarded parallel-plate electrodes have the advantage that single specimens can be measured with full accuracy. Also a prior knowledge of the permittivity of the liquid is not required as it can be measured directly (11). If the cell is constructed with a micrometer electrode, specimens having widely different thicknesses can be measured with high accuracy since the electrodes can be adjusted to a spacing only slightly greater than the thickness of the specimen. If the permittivity of the fluid approximates that of the specimen, the effect of errors in determination of specimen thicknesses are minimized. The use of a nearly matching liquid and a micrometer cell permits high accuracy in measuring even very thin film.

7.3.3.1 All necessity for determining specimen thickness and electrode spacing is eliminated if successive measurements are made in two fluids of known permittivity (12, 13, 18). This method is not restricted to any frequency range; however, it is best to limit use of liquid immersion methods to frequencies for which the dissipation factor of the liquid is less than 0.01 (preferably less than 0.0001 for low-loss specimens).

7.3.3.2 When using the two-fluid method it is important that both measurements be made on the same area of the specimen as the thickness may not be the same at all points. To ensure that the same area is tested both times and to facilitate the handling of thin films, specimen holders are convenient. The holder can be a U-shaped piece that will slide into grooves in the electrode cell. It is also necessary to control the temperature to at least 0.1°C. The cell may be provided with cooling coils for this purpose (13).

8. Choice of Apparatus and Methods for Measuring Capacitance and AC Loss

8.1 *Frequency Range*—Methods for measuring capacitance and ac loss can be divided into three groups: null methods, resonance methods, and deflection methods. The choice of a method for any particular case will depend primarily on the operating frequency. The resistive- or inductive-ratio-arm capacitance bridge in its various forms can be used over the frequency range from less than 1 Hz to a few megahertz. For frequencies below 1 Hz, special methods and instruments are required. Parallel-T networks are used at the higher frequencies from 500 kHz to 30 MHz, since they partake of some of the characteristics of resonant circuits. Resonance methods are used over a frequency range from 50 kHz to several hundred megahertz. The deflection method, using commercial indicating meters, is employed only at power-line frequencies from 25 to 60 Hz, where the higher voltages required can easily be obtained.

8.2 *Direct and Substitution Methods*— In any direct method, the values of capacitance and ac loss are in terms of all the circuit elements used in the method, and are therefore subject to all their errors. Much greater accuracy can be obtained by a substitution method in which readings are taken with the unknown capacitor both connected and disconnected. The errors in those circuit elements that are unchanged are in general eliminated; however, a connection error remains (Note 4).

8.3 *Two- and Three-Terminal Measurements*—The choice between three-terminal and two-terminal measurements is generally one between accuracy and convenience. The use of a guard electrode on the dielectric specimen nearly eliminates the effect of edge and ground capacitance, as explained in 6.2. The provision of a guard terminal eliminates some of the errors introduced by the circuit elements. On the other hand, the extra circuit elements and shielding usually required to provide the guard terminal add considerably to the size of the measuring equipment, and the number of adjustments required to obtain the final result may be increased many times. Guard circuits for resistive-ratio-arm capacitance bridges are rarely used at frequencies above 1 MHz. Inductive-ratio-arm bridges provide a guard terminal without requiring extra circuits or adjustments. Parallel-T networks and resonant circuits are not provided with guard circuits. In the deflection method a guard can be provided merely by extra shielding. The use of a two-terminal micrometer-electrode system provides many of the advantages of three-terminal measurements by nearly eliminating the effect of edge and ground capacitances but may increase the number of observations or balancing adjustments. Its use also eliminates the errors caused by series inductance and resistance in the connecting leads at the higher frequencies. It can be used over the entire frequency range to several hundred megahertz. When a guard is used, the possibility exists that the measured dissipation factor may be less than the true value. This is caused by resistance in the guard circuit at points between the guard point of the measuring circuit and the guard electrode. This may arise from high contact resistance, lead resistance, or from high resistance in the guard electrode itself. In extreme cases the dissipation factor may appear to be negative. This condition is most likely to exist when the dissipation factor without the guard is higher than normal due to surface leakage. Any point capacitively coupled to the measuring electrodes and resistively coupled to the guard point can be a source of difficulty. The common guard resistance produces an equivalent negative dissipation factor proportional to $C_h C_l R_g$, where C_h and C_l are guard-to-electrode capacitances and R_g is the guard resistance (14).

8.4 *Fluid Displacement Methods*—The fluid displacement method may be employed using either three-terminal or self-shielded, two-terminal cells. With the three-terminal cell the permittivity of the fluids used may be determined directly. The self-shielded, two-terminal cell provides many of the advantages of the three-terminal cell by nearly eliminating the effects of edge and ground capacitance, and it may be used with measuring circuits having no provision for a guard. If it is equipped with an integral micrometer electrode, the effects on

the capacitance of series inductance in the connective leads at the higher frequencies may be eliminated.

8.5 *Accuracy*—The methods outlined in 8.1 contemplate an accuracy in the determination of permittivity of $\pm 1\%$ and of dissipation factor of $\pm (5\% + 0.0005)$. These accuracies depend upon at least three factors: the accuracy of the observations for capacitance and dissipation factor, the accuracy of the corrections to these quantities caused by the electrode arrangement used, and the accuracy of the calculation of the direct interelectrode vacuum capacitance. Under favorable conditions and at the lower frequencies, capacitance can be measured with an accuracy of $\pm (0.1\% + 0.02 \text{ pF})$ and dissipation factor with an accuracy of $\pm (2\% + 0.00005)$. At the higher frequencies these limits may increase for capacitance to $\pm (0.5\% + 0.1 \text{ pF})$ and for dissipation factor to $\pm (2\% + 0.0002)$. Measurements of dielectric specimens provided with a guard electrode are subject only to the error in capacitance and in the calculation of the direct interelectrode vacuum capacitance. The error caused by too wide a gap between the guarded and the guard electrodes will generally amount to several tenths percent, and the correction can be calculated to a few percent. The error in measuring the thickness of the specimen can amount to a few tenths percent for an average thickness of 2 mm, on the assumption that it can be measured to $\pm 0.005 \text{ mm}$. The diameter of a circular specimen can be measured to an accuracy of $\pm 0.1\%$, but enters as the square. Combining these errors, the direct interelectrode vacuum capacitance can be determined to an accuracy of $\pm 0.5\%$. Specimens with contact electrodes, measured with micrometer electrodes, have no corrections other than that for direct interelectrode capacitance, provided they are sufficiently smaller in diameter than the micrometer electrodes. When two-terminal specimens are measured in any other manner, the calculation of edge capacitance and determination of ground capacitance will involve considerable error, since each may be from 2 to 40% of the specimen capacitance. With the present knowledge of these capacitances, there may be a 10% error in calculating the edge capacitance and a 25% error in evaluating the ground capacitance. Hence the total error involved may be from several tenths to 10% or more. However, when neither electrode is grounded, the ground capacitance error is minimized (6.1). With micrometer electrodes, it is possible to measure dissipation factor of the order of 0.03 to within ± 0.0003 and dissipation factor of the order of 0.0002 to within ± 0.00005 of the true values. The range of dissipation factor is normally 0.0001 to 0.1 but may be extended above 0.1. Between 10 and 20 MHz it is possible to detect a dissipation factor of 0.00002. Permittivity from 2 to 5 may be determined to $\pm 2\%$. The accuracy is limited by the accuracy of the measurements required in the calculation of direct interelectrode vacuum capacitance and by errors in the micrometer-electrode system.

9. Sampling

9.1 See materials specifications for instructions on sampling.

10. Procedure

10.1 *Preparation of Specimens:*

10.1.1 *General*—Cut or mold the test specimens to a suitable shape and thickness determined by the material specification being followed or by the accuracy of measurement required, the test method, and the frequency at which the measurements are to be made. Measure the thickness in accordance with the standard method required by the material being tested. If there is no standard for a particular material, then measure thickness in accordance with Test Methods D 374. The actual points of measurement shall be uniformly distributed over the area to be covered by the measuring electrodes. Apply suitable measuring electrodes to the specimens (Section 7) (unless the fluid displacement method will be used), the choice as to size and number depending mainly on whether three-terminal or two-terminal measurements are to be made and, if the latter, whether or not a micrometer-electrode system will be used (7.3). The material chosen for the specimen electrodes will depend both on convenience of application and on whether or not the specimen must be conditioned at high temperature and high relative humidity (Section 7). Obtain the dimensions of the electrodes (of the smaller if they are unequal) preferably by a traveling microscope, or by measuring with a steel scale graduated to 0.25 mm and a microscope of sufficient power to allow the scale to be read to the nearest 0.05 mm. Measure the diameter of a circular electrode, or the dimensions of a rectangular electrode, at several points to obtain an average.

10.1.2 *Micrometer Electrodes*—The area of the specimen may be equal to or less than the area of the electrodes, but no part of the specimen shall extend beyond the electrode edges. The edges of the specimens shall be smooth and perpendicular to the plane of the sheet and shall also be sharply defined so that the dimensions in the plane of the sheet may be determined to the nearest 0.025 mm. The thickness may have any value from 0.025 mm or less to about 6 mm or greater, depending upon the maximum usable plate spacing of the parallel-plate electrode system. The specimens shall be as flat and uniform in thickness as possible, and free of voids, inclusions of foreign matter, wrinkles, and other defects. It has been found that very thin specimens may be tested more conveniently and accurately by using a composite of several or a large number of thicknesses. The average thickness of each specimen shall be determined as nearly as possible to within $\pm 0.0025 \text{ mm}$. In certain cases, notably for thin films and the like but usually excluding porous materials, it may be preferable to determine the average thickness by calculation from the known or measured density of the material, the area of the specimen face, and the mass of the specimen (or specimens, when tested in multiple thicknesses of the sheet), obtained by accurate weighing on an analytical balance.

10.1.3 *Fluid Displacement*—When the immersion medium is a liquid, the specimen may be larger than the electrodes if the permittivity of the standard liquid is within about 1% of that of the specimen (see Test Method D 1531). Also, duplicate specimens will normally be required for a cell of the type described in 7.3.3, although it is possible to test a single specimen at a time in such cells. In any case, the thickness of the specimen preferably should not be less than about 80% of

the electrode spacing, this being particularly true when the dissipation factor of the material being tested is less than about 0.001.

10.1.4 *Cleaning*—Since it has been found that in the case of certain materials when tested without electrodes the results are affected erratically by the presence of conducting contaminants on the surfaces of the specimens, clean the test specimens by a suitable solvent or other means (as prescribed in the material specification) and allow to dry thoroughly before test (15). This is particularly important when tests are to be made in air at low frequencies (60 to 10 000 Hz), but is less important for measurements at radio frequencies. Cleaning of specimens will also reduce the tendency to contaminate the immersion medium in the case of tests performed using a liquid medium. Refer to the ASTM standard or other document specifying this test for cleaning methods appropriate to the material being tested. After cleaning, handle the specimens only with tweezers and store in individual envelopes to preclude further contamination before testing.

10.2 *Measurement*—Place the test specimen with its attached electrodes in a suitable measuring cell, and measure its capacitance and a-c loss by a method having the required sensitivity and accuracy. For routine work when the highest accuracy is not required, or when neither terminal of the specimen is grounded, it is not necessary to place the solid specimen in a test cell.

10.2.1 **Warning**— *Lethal voltages are a potential hazard during the performance of this test. It is essential that the test apparatus, and all associated equipment electrically connected to it, be properly designed and installed for safe operation. Solidly ground all electrically conductive parts which it is possible for a person to contact during the test. Provide means for use at the completion of any test to ground any parts which were at high voltage during the test or have the potential for acquiring an induced charge during the test or retaining a charge even after disconnection of the voltage source. Thoroughly instruct all operators as to the correct procedures for performing tests safely. When making high voltage tests, particularly in compressed gas or in oil, it is possible for the energy released at breakdown to be sufficient to result in fire, explosion, or rupture of the test chamber. Design test equipment, test chambers, and test specimens so as to minimize the possibility of such occurrences and to eliminate the possibility of personal injury. If the potential for fire exists, have fire suppression equipment available.*

NOTE 2—The method used to connect the specimen to the measuring circuit is very important, especially for two-terminal measurements. The connection method by critical spacing, formerly recommended in Test Methods D 150 for parallel substitution measurements can cause a negative error of 0.5 pF. A similar error occurs when two-terminal specimens are measured in a cell used as a guard. Since no method for eliminating this error is presently known, when an error of this magnitude must be avoided, an alternative method must be used, that is, micrometer electrodes, fluid immersion cell, or three-terminal specimen with guarded leads.

NOTE 3—Detailed instructions for making the measurements needed to obtain capacitance and dissipation factor and for making any necessary corrections due to the measuring circuit are given in the instruction books supplied with commercial equipment. The following paragraphs are intended to furnish the additional instruction required.

10.2.2 *Fixed Electrodes*—Adjust the plate spacing accurately to a value suitable for the specimen to be tested. For low-loss materials in particular, the plate spacing and specimen thickness should be such that the specimen will occupy not less than about 80 % of the electrode gap. For tests in air, plate spacings less than about 0.1 mm are not recommended. When the electrode spacing is not adjustable to a suitable value, specimens of the proper thickness must be prepared. Measure the capacitance and dissipation factor of the cell, and then carefully insert and center the specimen between the electrodes of the micrometer electrodes or test cell. Repeat the measurements. For maximum accuracy determine ΔC and ΔD directly, if possible with the measuring equipment used. Record the test temperature.

10.2.3 *Micrometer Electrodes*—Micrometer electrodes are commonly used with the electrodes making contact with the specimen or its attached electrodes. To make a measurement first clamp the specimen between the micrometer electrodes, and balance or tune the network used for measurement. Then remove the specimen, and reset the electrodes to restore the total capacitance in the circuit or bridge arm to its original value by moving the micrometer electrodes closer together.

10.2.4 *Fluid Displacement Methods*—When a single liquid is used, fill the cell and measure the capacitance and dissipation factor. Carefully insert the specimen (or specimens if the two-specimen cell is used) and center it. Repeat the measurements. For maximum accuracy determine ΔC and ΔD directly, if possible with the measuring equipment used. Record the test temperature to the nearest 0.01°C. Remove specimens promptly from the liquid to prevent swelling, and refill the cell to the proper level before proceeding to test additional specimens. Equations for calculation of results are given in Table 2. Test Method D 1531 describes in detail the application of this method to the measurement of polyethylene. When a guarded cell of ruggedized construction, with provision for precise temperature control, such as recommended in Method B of Test Method D 1531 is available, greater accuracy can be obtained by measuring the specimen in two fluids. This method also eliminates the need to know the specimen dimensions. The procedure is the same as before except for the use of two fluids having different permittivities (12, 13, 18). It is convenient to use air as the first fluid since this avoids the necessity for cleaning the specimen between measurements. The use of a guarded cell permits the determination of the permittivity of the liquid or liquids used (3.2). When either the one- or two-fluid method is used, greatest accuracy is possible when the permittivity of one liquid most nearly matches that of the specimen.

NOTE 4—When the two-fluid method is used, the dissipation factor can be obtained from either set of readings (most accurately from the set with the higher κ_f').

10.3 *Calculation of Permittivity, Dissipation Factor, and Loss Index*—The measuring circuits used will give, for the specimen being measured at a given frequency, a value of capacitance and of a-c loss expressed as Q , dissipation factor, or series or parallel resistance. When the permittivity is to be calculated from the observed capacitance values, these values must be converted to parallel capacitance, if not so expressed,

TABLE 3 Calculation of Capacitance—Micrometer Electrodes

Parallel Capacitance	Definitions of Symbols
$C_p = C' - C_r + C_{vr}$	C' = calibration capacitance of the micrometer electrodes at the spacing to which the electrodes are reset, C_{vr} = vacuum capacitance for the area between the micrometer electrodes, which was occupied by the specimen, calculated using Table 1, C_r = calibration capacitance of the micrometer electrodes at the spacing r , and r = thickness of specimen and attached electrodes.
The true thickness and area of the specimen must be used in calculating the permittivity. This double calculation of the vacuum capacitance can be avoided with only small error (0.2 to 0.5 % due to fringing at the electrode edge), when the specimen has the same diameter as the electrodes, by using the following procedure and equation:	
$C_p = C' - C_v + C_{vt}$	C_v = calibration capacitance of the micrometer electrodes at the spacing t , C_{vt} = vacuum capacitance of the specimen area, and t = thickness of specimen

by the use of Eq 5. The equations given in Table 3 can be used in calculating the capacitance of the specimen when micrometer electrodes are used. The equations given in Table 2 for the different electrode systems can be used in calculating permittivity and dissipation factor. When the parallel substitution method is used, the dissipation factor readings must be multiplied by the ratio of the total circuit capacitance to the capacitance of the specimen or cell. Q and series or parallel resistance also require calculation from the observed values. Permittivity is:

$$\kappa_x' = C_p/C_v \quad (11)$$

Expressions for the vacuum capacitance (6.4) for flat parallel plates and coaxial cylinders are given in Table 1. When the a-c loss is expressed as series resistance or parallel resistance or conductance, the dissipation factor may be calculated using the relations given in Eq 3 and 4 (See 3.1.2.1). Loss index is the product of dissipation factor and permittivity (See 3.4).

10.4 *Corrections*—The leads used to connect the specimen to the measuring circuit have both inductance and resistance which, at high frequencies, increase the measured capacitance and dissipation factor. When extra capacitances have been included in the measurements, such as edge capacitance, and ground capacitance, which may occur in two-terminal measurements, the observed parallel capacitance will be increased and the observed dissipation factor will be decreased. Corrections for these effects are given in Appendix X1 and Table 1.

11. Report

11.1 Report the following information:

11.1.1 Description of the material tested, that is, the name, grade, color, manufacturer, and other pertinent data,

- 11.1.2 Shape and dimensions of the test specimen,
- 11.1.3 Type and dimensions of the electrodes and measuring cell,
- 11.1.4 Conditioning of the specimen, and test conditions,
- 11.1.5 Method of measurement and measurement circuit,
- 11.1.6 Applied voltage, effective voltage gradient, and frequency, and
- 11.1.7 Values of parallel capacitance, dissipation factor or power factor, permittivity, loss index, and estimated accuracy.

12. Precision and Bias

12.1 *Precision*—It is not practicable to make a statement about the precision of any one test method set forth herein since precision is influenced by the material being tested and the choice of apparatus used for the measurement. Users of these test methods for specific materials are encouraged to seek statements of precision in standards applicable to specific materials (see Section 8 also).

12.2 *Bias*—No statement about the bias of any one or all of these test methods can be made.

13. Keywords

13.1 ac loss; capacitance: parallel, series, fringing, stray; conductance; contacting electrodes; dielectric; dielectric constant; dissipation factor; electrical insulating material; electrode; fluid displacement; frequency; fringing capacitance; guarded electrode; Hz; loss angle; loss factor; loss tangent; non-contacting electrodes; permittivity; phase angle; phase defect angle; power factor; Q ; quality factor; reactance: parallel, series; relative permittivity; resistance: parallel, series; $\tan(\delta)$; thickness

APPENDIXES
(Nonmandatory Information)
X1. CORRECTIONS FOR SERIES INDUCTANCE AND RESISTANCE AND STRAY CAPACITANCES

X1.1 The increase in capacitance due to the inductance of the leads and of dissipation factor due to the resistance of the leads is calculated as follows:

$$\begin{aligned}\Delta C &= \omega^2 L_s C_p^2 \\ \Delta D &= R_s \omega C_p\end{aligned}\quad (X1.1)$$

where:

- C_p = true capacitance of the capacitor being measured,
- L_s = series inductance of the leads,
- R_s = series resistance of the leads, and
- ω = 2π times the frequency, Hz.

NOTE X1.1— L and R can be calculated for the leads used, from measurements of a physically small capacitor, made both at the measuring equipment terminals and at the far end of the leads. C is the capacitance measured at the terminals, ΔC is the difference between the two capacitance readings, and R is calculated from the measured values of C and D .

X1.2 While it is desirable to have these leads as short as possible, it is difficult to reduce their inductance and resistance below $0.1 \mu\text{H}$ and 0.05Ω at 1 MHz. The high-frequency resistance increases with the square root of the frequency. Hence these corrections become increasingly important above 1 MHz. When extra capacitances have been included in the measurements, such as edge capacitance, C_e , and ground capacitance, C_g , which may occur in two-terminal measurements, the observed parallel capacitance will be increased and

the observed dissipation factor will be decreased. Designating these observed quantities by the subscript, m , the corrected values are calculated as follows:

$$\begin{aligned}C_p &= C_m - (C_e + C_g) \\ D &= C_m D_m / C_p \\ &= C_m D_m / [C_m - (C_e + C_g)]\end{aligned}\quad (X1.2)$$

X1.3 The expression for dissipation factor assumes that the extra capacitances are free from loss. This is essentially true for ground capacitance except at low frequencies, and also for edge capacitance when the electrodes extend to the edge of the specimen, since nearly all of the flux lines are in air. The permittivity and loss index are calculated as follows:

$$\begin{aligned}\kappa' &= C_p / C_v = [C_m - (C_e + C_g)] / C_v \\ \kappa'' &= C_m D_m / C_v\end{aligned}\quad (X1.3)$$

X1.4 When one or both of the electrodes are smaller than the specimen, the edge capacitance has two components. The capacitance associated with the flux lines that pass through the surrounding dielectric has a dissipation factor which, for isotropic materials, is the same as that of the body of the dielectric. There is no loss in the capacitance associated with the flux lines through the air. Since it is not practicable to separate the capacitances, the usual practice is to consider the measured dissipation factor to be the true dissipation factor.

X2. EFFECTIVE AREA OF GUARDED ELECTRODE

X2.1 A guarded electrode has a gap between the measuring electrode and the guard electrode. That gap has definite dimensions which define a gap area.

X2.1.1 The effective area of a guarded electrode is greater than its actual area. In most guarded electrode systems, the increase is approximately 50 % of the guard-gap area.

X2.1.2 To obtain the effective area of an electrode system using a guarded electrode, increase each of the following dimensions by the width of the air gap, and use these increased dimensions in the formula for the area:

- a. the diameter of a circular measuring electrode,
- b. each dimension of a rectangular measuring electrode,
- c. the length of a cylindrical measuring electrode.

X2.1.3 For those cases in which the ratio of the gap width, g , to the electrode separation, t , (approximately the thickness of the specimen) is appreciable, the increase in the dimension of the guarded electrode is less than the gap width by a quantity identified as the guard-gap correction. The guard-gap correction symbol is: 2δ .

X2.1.4 The guard-gap correction is affected by g , the guard-gap width; t , the electrode separation distance which approximates the thickness of the specimen; a , the thickness of

the guarded measuring electrode; $1/\kappa'$, the permittivity of the medium between the high-voltage and low-voltage electrodes; and κ'_g , the permittivity of the medium in the gap. The effective factors are:

- X2.1.4.1 Ratio g/t
- X2.1.4.2 The ratio a/g
- X2.1.4.3 The ratio κ'/κ'_g

X2.2 Exact equations for calculating $2\delta/g$ for certain ratios of κ'/κ'_g and a/g (16) are shown in Eq X2.1-X2.3:

X2.3 The fraction of the guard gap to be added to the overall electrode dimension before calculating the effective electrode area is $B = 1 - 2\delta/g$. Taking into account (b) and (c) above (16), B may be calculated from the empirical equation in Eq X2.4.

A is a function of the ratio a/g . When $a/g = 0$ (thin electrodes), $A = 1$. When a/g is one or greater than one (thick electrodes), A approaches the limit 0.8106 (exactly $8/\pi^2$). Intermediate values of A can be read from Fig. X2.1.

X2.4 The ratio of $\ln B$ from Eq X2.2 to $\ln B$ Eq X2.1 is very nearly 1.23 for $g/t \leq 10$. Therefore, the necessity for evaluating

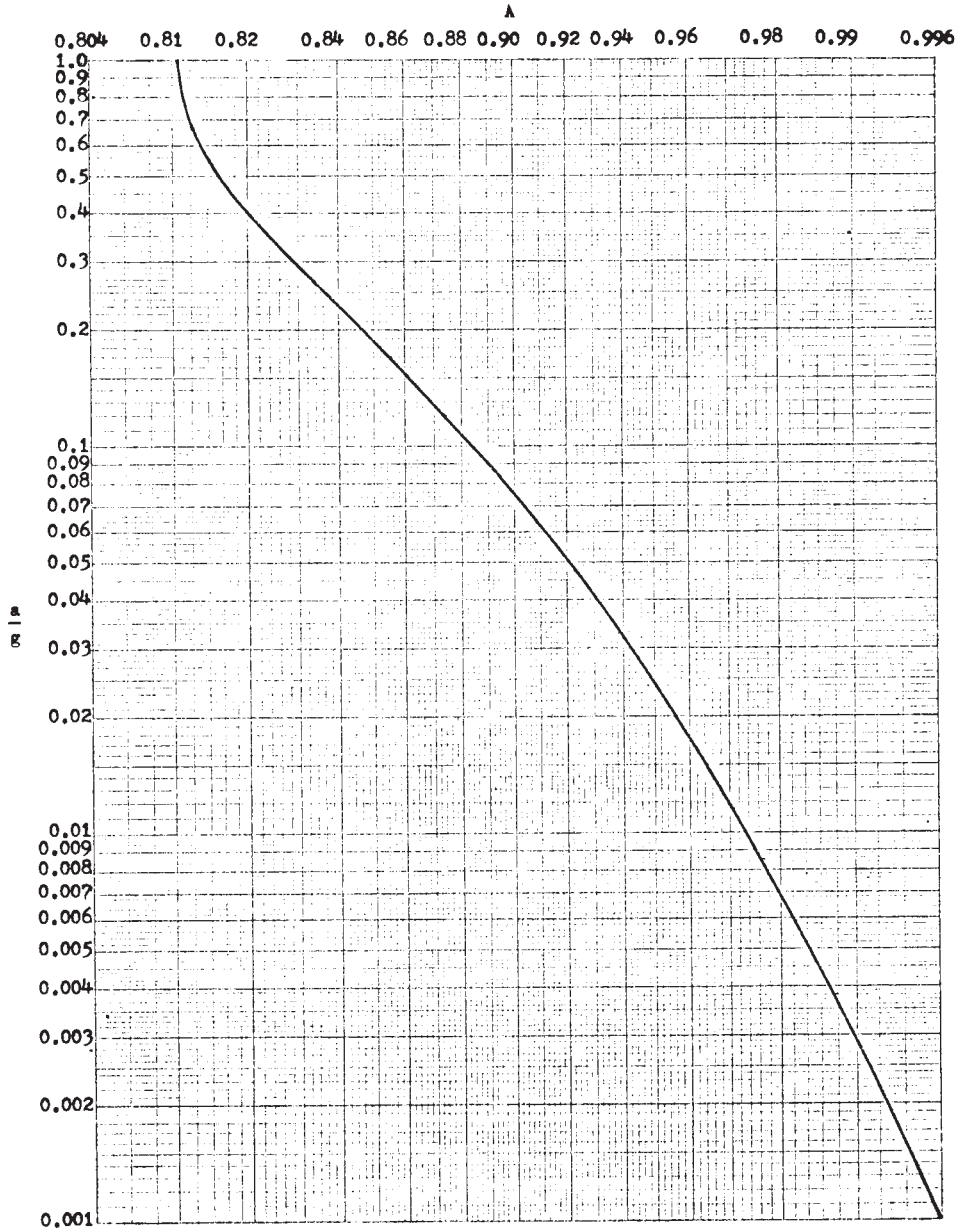

FIG. X2.1 A versus a/g

Eq X2.2 can be eliminated by writing Eq X2.4 as shown in Eq X2.5.

X2.5 Values of B calculated from Eq X2.5 will differ from the exact values by a maximum of 0.01. For a 0.25-mm guard

gap this maximum error would give a 0.0025-mm error in electrode diameter or electrode dimension. For a 25-mm electrode this would be an error of 0.02 % in area.

$$\frac{2\delta}{g} = \frac{2}{\pi} \tan^{-1} \left(\frac{g}{2t} \right) - \frac{2t}{\pi g} \ln \left[1 + \left(\frac{g}{2t} \right)^2 \right] \quad (X2.1)$$

where:

$$\begin{aligned} \kappa' &= \kappa'_g, a/g \rightarrow \infty \\ \frac{2\delta}{g} &= \frac{2t}{\pi g} \frac{(\sqrt{p} - 1)^2}{2\sqrt{p}} \\ \frac{\pi g}{2t} &= \frac{\ln p}{2} + \frac{p-1}{2\sqrt{p}} \end{aligned} \quad (X2.2)$$

where:

$$\begin{aligned} \kappa' &= \kappa'_g, a/g \rightarrow 0 \\ \frac{2\delta}{g} &= \frac{4t}{\pi g} \ln \cosh \left(\frac{\pi g}{4t} \right) \end{aligned} \quad (X2.3)$$

where:

$$\kappa' \gg \kappa_g', \text{ a/g any value}$$

$$B = \text{antiln} \left\{ \ln B(\kappa' \gg \kappa_g') \left[\frac{\kappa'}{A \ln B(\kappa' = \kappa_g', a/g \rightarrow 0)} - 1 \right] \kappa_g' \right\} \quad (X2.4)$$

$$B = \text{antiln} \left\{ \ln B(\kappa' \gg \kappa_g') \left[\frac{\kappa'}{1.23 \times A \ln B(\kappa' \approx \kappa_g', a/g \rightarrow \infty)} - 1 \right] \kappa_g' \right\} \quad (X2.5)$$

X3. FACTORS AFFECTING PERMITTIVITY AND LOSS CHARACTERISTICS

X3.1 Frequency

X3.1.1 Insulating materials are used over the entire electromagnetic spectrum, from direct current to radar frequencies of at least 3×10^{10} Hz. There are only a very few materials, such as polystyrene, polyethylene, and fused silica, whose permittivity and loss index are even approximately constant over this frequency range. It is necessary either to measure permittivity and loss index at the frequency at which the material will be used or to measure them at several frequencies suitably placed, if the material is to be used over a frequency range.

X3.1.2 The changes in permittivity and loss index with frequency are produced by the dielectric polarizations which exist in the material. The two most important are dipole polarization due to polar molecules and interfacial polarization caused by inhomogeneities in the material. Permittivity and loss index vary with frequency in the manner shown in Fig. X3.1 (17). Starting at the highest frequency where the permittivity is determined by an atomic or electronic polarization, each succeeding polarization, dipole or interfacial, adds its contribution to permittivity with the result that the permittivity has its maximum value at zero frequency. Each polarization furnishes a maximum of both loss index and dissipation factor. The frequency at which loss index is a maximum is called the relaxation frequency for that polarization. It is also the frequency at which the permittivity is increasing at the greatest rate and at which half its change for that polarization has occurred. A knowledge of the effects of these polarizations will frequently help to determine the frequencies at which measurements should be made.

X3.1.3 Any dc conductance in the dielectric caused by free ions or electrons, while having no direct effect on permittivity,

will produce a dissipation factor that varies inversely with frequency, and that becomes infinite at zero frequency (dotted line in Fig. X3.1).

X3.2 Temperature

X3.2.1 The major electrical effect of temperature on an insulating material is to increase the relaxation frequencies of its polarizations. They increase exponentially with temperature at rates such that a tenfold increase in relaxation frequency may be produced by temperature increments ranging from 6 to 50°C. The temperature coefficient of permittivity at the lower frequencies would always be positive except for the fact that the temperature coefficients of permittivity resulting from many atomic and electronic polarizations are negative. The temperature coefficient will then be negative at high frequencies, become zero at some intermediate frequency and positive as the relaxation frequency of the dipole or interfacial polarization is approached.

X3.2.2 The temperature coefficient of loss index and dissipation factor may be either positive or negative, depending on the relation of the measuring to the relaxation frequency. It will be positive for frequencies higher than the relaxation frequency and negative for lower frequencies. Since the relaxation frequency of interfacial polarization is usually below 1 Hz, the corresponding temperature coefficient of loss index and dissipation factor will be positive at all usual measuring frequencies. Since the dc conductance of a dielectric usually increases exponentially with decrease of the reciprocal of absolute temperature, the values of loss index and dissipation factor arising therefrom will increase in a similar manner and will produce a larger positive temperature coefficient.

X3.3 Voltage

X3.3.1 All dielectric polarizations except interfacial are nearly independent of the existing potential gradient until such a value is reached that ionization occurs in voids in the material or on its surface, or that breakdown occurs. In interfacial polarization the number of free ions may increase with voltage and change both the magnitude of the polarization and its relaxation frequency. The dc conductance is similarly affected.

X3.4 Humidity

X3.4.1 The major electrical effect of humidity on an insulating material is to increase greatly the magnitude of its interfacial polarization, thus increasing both its permittivity and loss index and also its dc conductance. These effects of

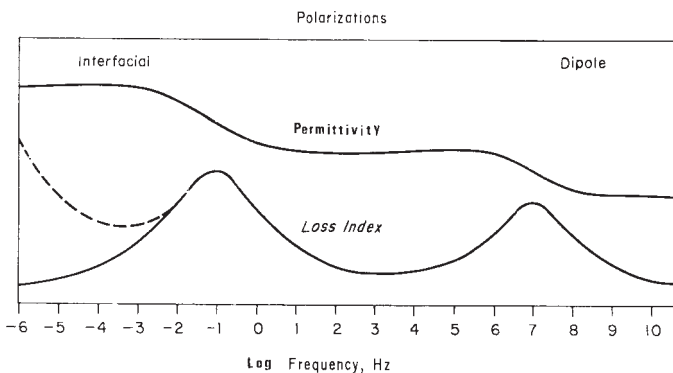

FIG. X3.1 Typical Polarizations (17)

humidity are caused by absorption of water into the volume of the material and by the formation of an ionized water film on its surface. The latter forms in a matter of minutes, while the former may require days and sometimes months to attain equilibrium, particularly for thick and relatively impervious materials (15).

X3.5 Water Immersion

X3.5.1 The effect of water immersion on an insulating material approximates that of exposure to 100 % relative humidity. Water is absorbed into the volume of the material, usually at a greater rate than occurs under a relative humidity of 100 %. However, the total amount of water absorbed when equilibrium is finally established is essentially the same under the two conditions. If there are water-soluble substances in the material, they will leach out much faster under water immersion than under 100 % relative humidity without condensation. If the water used for immersion is not pure, its impurities may be carried into the material. When the material is removed from the water for measurement, the water film formed on its surface will be thicker and more conducting than that produced by a 100 % relative humidity without condensation, and will require some time to attain equilibrium.

X3.6 Weathering

X3.6.1 Weathering, being a natural phenomenon, includes the effects of varying temperature and humidity, of falling rain, severe winds, impurities in the atmosphere, and the ultraviolet light and heat of the sun. Under such conditions the surface of an insulating material may be permanently changed, physically by roughening and cracking, and chemically by the loss of the more soluble components and by the reactions of the salts, acids, and other impurities deposited on the surface. Any water

film formed on the surface will be thicker and more conducting, and water will penetrate more easily into the volume of the material.

X3.7 Deterioration

X3.7.1 Under operating conditions of voltage and temperature, an insulating material may deteriorate in electric strength because of the absorption of moisture, physical changes of its surface, chemical changes in its composition, and the effects of ionization both on its surface and on the surfaces of internal voids. In general, both its permittivity and its dissipation factor will be increased, and these increases will be greater the lower the measuring frequency. With a proper understanding of the effects outlined in X3.1-X3.6, the observed changes in any electrical property, particularly dissipation factor, can be made a measure of deterioration and hence of decrease in dielectric strength.

X3.8 Conditioning

X3.8.1 The electrical characteristics of many insulating materials are so dependent on temperature, humidity, and water immersion, as indicated in the paragraphs above, that it is usually necessary to specify the past history of a specimen and its test conditions regarding these factors. Unless measurements are to be made at room temperature (20 to 30°C) and unspecified relative humidity, the specimen should be conditioned in accordance with Practice D 618. The procedure chosen should be that which most nearly matches operating conditions. When data are required covering a wide range of temperature and relative humidity, it will be necessary to use intermediate values and possibly to condition to equilibrium.

X3.8.2 Methods of maintaining specified relative humidities are described in Practices D 5032 and E 104.

X3.8.3 Specifications for conditioning units are given in Specifications E 197.

X4. CIRCUIT DIAGRAMS OF TYPICAL MEASURING CIRCUITS

X4.1 The simplified circuits and equations presented in Figs. X4.1-X4.9 are for general information only. The instruction book accompanying a particular piece of equipment

should be consulted for the exact diagram, equations, and method of measurement to be used.

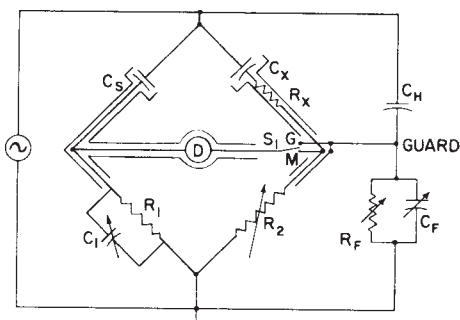

Equations
 $C_x = (R_1/R_2)C_s$
 $D_x = \omega R_1 C_1$

Method of Balance
 Vary C_1 and R_2 with S_1 in position M to obtain minimum deflection in Detector D . Repeat with S_1 in position G by varying C_F and R_F . Repeat the above until the detector shows no change in balance by switching S_1 to M or G .

NOTE 1—This type of bridge is especially useful for high-voltage measurements at power frequencies as almost all of the applied voltage appears across the standard capacitor, C_s , and the specimen, C_x . The balancing circuits and detector are very nearly at ground potential.

FIG. X4.1 High-Voltage Schering Bridge

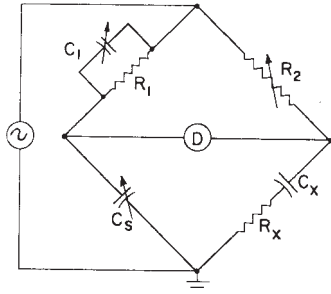

Equations
 $C_x = (R_1/R_2)C_s$
 $D_x = \omega C_1 R_1$

Method of Balance
 Set ratio of R_1 to R_2 (range) and vary C_s and C_1 to obtain balance.

FIG. X4.2 Low-Voltage Schering Bridge, Direct Method

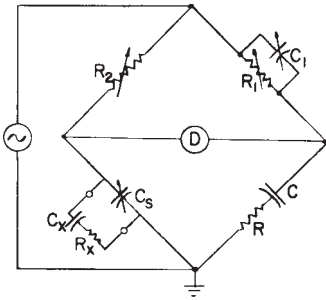

Equations
 $C_x = \Delta C_s$
 $\Delta C_s = C_s' - C_s$
 $D_x = (C_s'/\Delta C_s)\Delta C_1 \omega R_1$
 $\Delta C_1 = C_1 - C_1'$

Method of Balance
 Vary C_1 and C_s , without and with the specimen connected, to obtain balance. Symbols used for the initial balance, with the ungrounded lead to the unknown disconnected, are primed.

FIG. X4.3 Low-Voltage Schering Bridge, Parallel Substitution Method

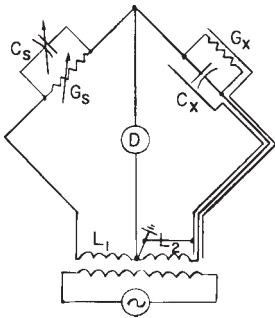

Equations
 $C_x = (L_1/L_2)C_s$
 $G_x = (L_1/L_2)G_s$
 $D_x = (G_s/\omega C_s)$

Method of Balance
 Set ratio of L_1 to L_2 (range) and adjust C_s and G_s to obtain balance.

FIG. X4.4 Inductive-Ratio-Arm (Transformer) Circuit

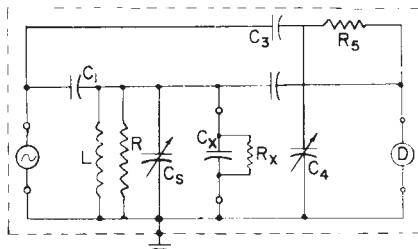

Equations
 $C_x = C_s' - C_s = \Delta C_s$
 $G_x = (R_5 \omega^2 C_1 C_2 / C_s)(C_4 - C_4')$
 $= \Delta G_x$
 $D_x = G_x / \omega C_x = \Delta G_x / \omega \Delta C_s$

Method of Balance
 Balance without and rebalance with unknown connected, using C_s and C_4 . Symbols used for the initial balance are primed.

FIG. X4.5 Parallel-T Network, Parallel Substitution Method

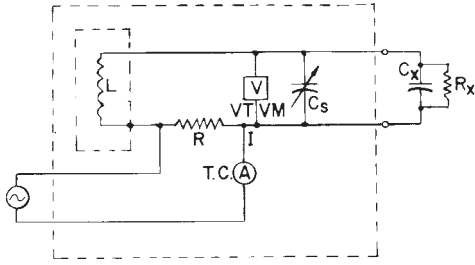

Equations

$$C_x = \Delta C_s$$

$$\Delta C_s = C_{s1} - C_{s2}$$

$$Q_x = (\Delta C_s / C_{s1}) (Q_1 Q_2 / \Delta Q)$$

$$\Delta Q = Q_1 - Q_2$$

Method of Balance

Adjust to resonance, without and with the specimen, noting I , maximum V and C_s . With a standard I , V on the VTVM can be calibrated in terms of Q , since $Q = V/IR$. Subscripts 1 and 2 denote first and second balance respectively.

FIG. X4.6 Resonant-Rise (Q-Meter) Method

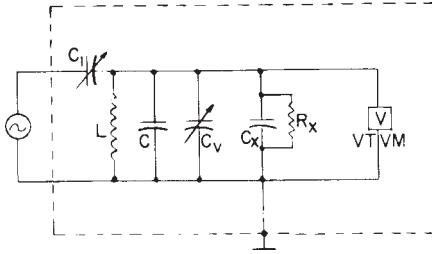

Equations

$$C_x = \Delta C_v$$

$$\Delta C_v = C_{v1} - C_{v2}$$

$$D_x = [(C_{v1} - C_{v2}) / 2C_x] (V' - V) / V$$

or

$$D_x = [(C_{v1} - C_{v2}) - (C_{v1} - C_{v2})] / 2C_x$$

Method of Balance

Adjust C_1 so maximum resonance V' is just under full scale. Note exact V' and capacitance C_{v1} . Adjust C_v so that $V_a (= 0.707 V')$ is first on one side of the resonance V' and then on the other. Record C_{v1} and C_{v2} . Repeat last process with C_x connected, noting C_{v1} and C_{v2} , C_v and V .

FIG. X4.7 Susceptance-Variation Method

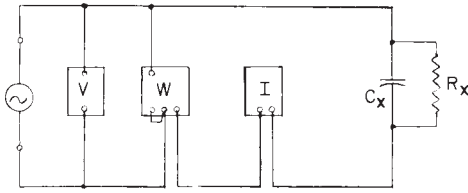

Equations

$$C_x = (I/\omega V) \times \sqrt{1 - (\cos \theta)^2}$$

$$\cos \theta_x = W/VI$$

$$D_x = \cos \theta / \sqrt{1 - (\cos \theta)^2}$$

Method
Using proper scale multiplier, read indications with unknown connected.

NOTE 1—This method is for use at power frequencies. Instrument corrections should be applied and an unusually sensitive wattmeter is required due to small losses. Errors from stray fields should be eliminated by shielding. Accuracy depends on combined instrument errors and is best at full scale.

FIG. X4.8 Voltmeter-Wattmeter-Ammeter Method

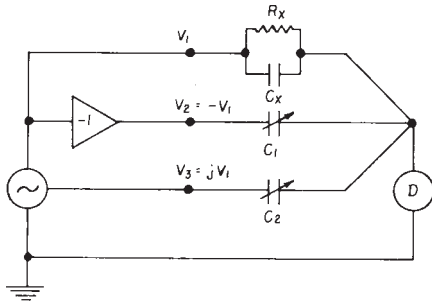

Equations

$$C_x = C_1 \frac{1}{\omega C_2}$$

$$D_x = \frac{C_2}{C_1}$$

Assumption: The amplitudes of V_1 , V_2 and V_3 are equal.

Method of Balance
Adjust C_1 and C_2 to obtain null.

NOTE 1—This circuit requires a source providing at least two outputs, one in quadrature phase relationship with the others. A third phase, 180 deg from the reference, if not available directly from the source, can be achieved by means of an inverting, unity-gain operation amplifier. This circuit is useful from frequencies as low as 0.001 Hz (with proper detector) to as high as 10 kHz (with appropriate corrections for phase errors). Accuracy to within 0.1 % of C_x is easily attained using a fully shielded (three-terminal) system. Shield is not shown.

FIG. X4.9 Ultra-Low-Frequency Bridge Using Multiphase Source.

REFERENCES

- (1) Hector, L. G. and Woernley, D. L., "The Dielectric Constants of Eight Gases", *Physical Review*, PHRVA, Vol 69, February 1964, pp. 101-105.
- (2) Ford, L. H., "The Effect of Humidity on the Calibration of Precision Air Capacitors", *Proceedings*, PIEEA, Institution of Electrical Engineers (London), Vol 96, Part III, January 1949, pp. 13-16.
- (3) Essen, L. and Freome, K. O., "Dielectric Constant and Refractive Index of Air and Its Principal Constituents at 24,000 Mc/s", *Nature*, NTRWA, Vol 167, March 31, p. 512.
- (4) Scott, A. H., and Curtis, H. L., "Edge Correction in the Determination of Dielectric Constant," *Journal of Research*, JNBAA, Nat. Bureau Standards, Vol 22, June, 1939, pp. 747-775.
- (5) Amey, W. G., and Hamburger, F., Jr., "A Method for Evaluating the Surface and Volume Resistance Characteristics of Solid Dielectric Materials," *Proceedings*, ASTEA, Am. Soc. Testing Mats., Vol 49, 1949, pp. 1079-1091.
- (6) Field, R. F., "Errors Occurring in the Measurement of Dielectric Constant," *Proceedings*, ASTEA, Am. Soc. Testing Mats., Vol 54, 1954, pp. 456-478.
- (7) Moon, C., and Sparks, C. M., "Standards for Low Values of Direct Capacitance," *Journal of Research*, JNBAA, Nat. Bureau Standards, Vol 41, November, 1948, pp. 497-507.
- (8) Hartshorn, L., and Ward, W. H., "The Measurement of the Permittivity and Power Factor of Dielectrics at Frequencies from 10^4 to 10^8 Cycles per Second," *Proceedings*, PIEEA, Institution of Electrical Engineers (London), Vol 79, 1936, pp. 597-609; or *Proceedings of the Wireless Section, Ibid.*, Vol 12, March, 1937, pp. 6-18.
- (9) Coutlee, K. G., "Liquid Displacement Test Cell for Dielectric Constant and Dissipation Factor up to 100 Mc," presented at Conference on Electrical Insulation (NRC), October, 1959, and reviewed in *Insulation*, INULA, November, 1959, p. 26.
- (10) Maryott, A. A., and Smith, E. R., "Table of Dielectric Constants of Pure Liquids," NBS Circular No. 514, 1951.
- (11) Hartshorn, L., Parry, J. V. L., and Essen, L., "The Measurement of the Dielectric Constant of Standard Liquids," *Proceedings*, PPSBA, Physical Soc. (London), Vol 68B, July, 1955, pp. 422-446.
- (12) Harris, W. P., and Scott, A. H., "Precise Measurement of the Dielectric Constant by the Two-fluid Technique," 1962 Annual Report, Conference on Electrical Insulation, NAS-NAC, p. 51.
- (13) Endicott, H. S., and McGowan, E. J., "Measurement of Permittivity and Dissipation Factor Without Attached Electrodes," 1960 Annual Report, Conference on Electrical Insulation, NAS-NAC.
- (14) Harris, W. P., "Apparent Negative Impedances and their Effect on Three-terminal Dielectric Loss Measurements," 1965 Annual Report, Conference on Electrical Insulation, NAS-NRC Publication 1356.
- (15) Field, R. F., "The Formation of Ionized Water Films on Dielectrics Under Conditions of High Humidity," *Journal Applied Physics*, JAPIA, Vol 17, May, 1946, pp. 318-325.
- (16) Lauritzen, J. I., "The Effective Area of a Guarded Electrode," 1963 Annual Report, Conference on Electrical Insulation, NAS-NRC Publication 1141.
- (17) Murphy, E. J., and Morgan, S. O., "The Dielectric Properties of Insulating Materials," *Bell System Technical Journal*, BSTJA, Vol 16, October, 1937, pp. 493-512.
- (18) Endicott, H. S., "Guard Gap Corrections for Guarded-Electrical Measurements and Exact Equations for the Two-Fluid Method of Measuring Permittivity and Loss," *Journal of Testing and Evaluation*, JTEVA, Vol 4, No. 3, May 1976, pp. 188-195.

ASTM International takes no position respecting the validity of any patent rights asserted in connection with any item mentioned in this standard. Users of this standard are expressly advised that determination of the validity of any such patent rights, and the risk of infringement of such rights, are entirely their own responsibility.

This standard is subject to revision at any time by the responsible technical committee and must be reviewed every five years and if not revised, either reapproved or withdrawn. Your comments are invited either for revision of this standard or for additional standards and should be addressed to ASTM International Headquarters. Your comments will receive careful consideration at a meeting of the responsible technical committee, which you may attend. If you feel that your comments have not received a fair hearing you should make your views known to the ASTM Committee on Standards, at the address shown below.

This standard is copyrighted by ASTM International, 100 Barr Harbor Drive, PO Box C700, West Conshohocken, PA 19428-2959, United States. Individual reprints (single or multiple copies) of this standard may be obtained by contacting ASTM at the above address or at 610-832-9585 (phone), 610-832-9555 (fax), or service@astm.org (e-mail); or through the ASTM website (www.astm.org).