



Standard Test Method for Compressive Properties of Rigid Plastics¹

This standard is issued under the fixed designation D 695; the number immediately following the designation indicates the year of original adoption or, in the case of revision, the year of last revision. A number in parentheses indicates the year of last reapproval. A superscript epsilon (ϵ) indicates an editorial change since the last revision or reapproval.

This standard has been approved for use by agencies of the Department of Defense.

1. Scope *

1.1 This test method covers the determination of the mechanical properties of unreinforced and reinforced rigid plastics, including high-modulus composites, when loaded in compression at relatively low uniform rates of straining or loading. Test specimens of standard shape are employed.

1.2 The values stated in SI units are to be regarded as the standard. The values in parentheses are for information only.

NOTE 1—For compressive properties of resin-matrix composites reinforced with oriented continuous, discontinuous, or cross-ply reinforcements, tests may be made in accordance with Test Method D 3410.

1.3 *This standard does not purport to address all of the safety concerns, if any, associated with its use. It is the responsibility of the user of this standard to establish appropriate safety and health practices and determine the applicability of regulatory limitations prior to use.* A specific precautionary statement is given in Note 11.

NOTE 2—This test method is technically equivalent to ISO 604.

2. Referenced Documents

2.1 ASTM Standards:

- D 618 Practice for Conditioning Plastics for Testing²
- D 638 Test Method for Tensile Properties of Plastics²
- D 883 Terminology Relating to Plastics²
- D 3410 Test Method for Compressive Properties of Polymer Matrix Composite Materials with Unsupported Gage Section by Shear Loading³
- D 4000 Classification System for Specifying Plastic Materials⁴
- D 4066 Classification System for Nylon Injection and Extrusion Materials⁴
- D 5947 Test Methods for Physical Dimensions of Solid Plastics Specimens⁵

¹ This test method is under the jurisdiction of ASTM Committee D20 on Plastics and is the direct responsibility of Subcommittee D20.10 on Mechanical Properties.

Current edition approved August 10, 2002. Published October 2002. Originally published as D 695 – 42 T. Last previous edition D 695 – 02.

² Annual Book of ASTM Standards, Vol 08.01.

³ Annual Book of ASTM Standards, Vol 15.03.

⁴ Annual Book of ASTM Standards, Vol 08.02.

⁵ Annual Book of ASTM Standards, Vol 08.03.

- E 4 Practices for Force Verification of Testing Machines⁶
- E 83 Practice for Verification and Classification of Extensometers⁶
- E 691 Practice for Conducting an Interlaboratory Study to Determine the Precision of a Test Method⁷

3. Terminology

3.1 General— The definitions of plastics used in this test method are in accordance with Terminology D 883 unless otherwise indicated.

3.2 Definitions:

3.2.1 *compressive deformation*—the decrease in length produced in the gage length of the test specimen by a compressive load. It is expressed in units of length.

3.2.2 *compressive strain*—the ratio of compressive deformation to the gage length of the test specimen, that is, the change in length per unit of original length along the longitudinal axis. It is expressed as a dimensionless ratio.

3.2.3 *compressive strength*—the maximum compressive stress (nominal) carried by a test specimen during a compression test. It may or may not be the compressive stress (nominal) carried by the specimen at the moment of rupture.

3.2.4 *compressive strength at failure (nominal)*—the compressive stress (nominal) sustained at the moment of failure of the test specimen if shattering occurs.

3.2.5 *compressive stress (nominal)*—the compressive load per unit area of minimum original cross section within the gage boundaries, carried by the test specimen at any given moment. It is expressed in force per unit area.

3.2.5.1 *Discussion*—The expression of compressive properties in terms of the minimum original cross section is almost universally used. Under some circumstances the compressive properties have been expressed per unit of prevailing cross section. These properties are called “true” compressive properties.

3.2.6 *compressive stress-strain diagram*—a diagram in which values of compressive stress are plotted as ordinates against corresponding values of compressive strain as abscissas.

⁶ Annual Book of ASTM Standards, Vol 03.01.

⁷ Annual Book of ASTM Standards, Vol 14.02.

*A Summary of Changes section appears at the end of this standard.

3.2.7 *compressive yield point*—the first point on the stress-strain diagram at which an increase in strain occurs without an increase in stress.

3.2.8 *compressive yield strength*—normally the stress at the yield point (see also section 3.2.11).

3.2.9 *crushing load*—the maximum compressive force applied to the specimen, under the conditions of testing, that produces a designated degree of failure.

3.2.10 *modulus of elasticity*—the ratio of stress (nominal) to corresponding strain below the proportional limit of a material. It is expressed in force per unit area based on the average initial cross-sectional area.

3.2.11 *offset compressive yield strength*—the stress at which the stress-strain curve departs from linearity by a specified percent of deformation (offset).

3.2.12 *percent compressive strain*—the compressive deformation of a test specimen expressed as a percent of the original gage length.

3.2.13 *proportional limit*—the greatest stress that a material is capable of sustaining without any deviation from proportionality of stress to strain (Hooke's law). It is expressed in force per unit area.

3.2.14 *slenderness ratio*—the ratio of the length of a column of uniform cross section to its least radius of gyration. For specimens of uniform rectangular cross section, the radius of gyration is 0.289 times the smaller cross-sectional dimension. For specimens of uniform circular cross section, the radius of gyration is 0.250 times the diameter.

4. Significance and Use

4.1 Compression tests provide information about the compressive properties of plastics when employed under conditions approximating those under which the tests are made.

4.2 Compressive properties include modulus of elasticity, yield stress, deformation beyond yield point, and compressive strength (unless the material merely flattens but does not fracture). Materials possessing a low order of ductility may not exhibit a yield point. In the case of a material that fails in compression by a shattering fracture, the compressive strength has a very definite value. In the case of a material that does not fail in compression by a shattering fracture, the compressive strength is an arbitrary one depending upon the degree of distortion that is regarded as indicating complete failure of the material. Many plastic materials will continue to deform in compression until a flat disk is produced, the compressive stress (nominal) rising steadily in the process, without any well-defined fracture occurring. Compressive strength can have no real meaning in such cases.

4.3 Compression tests provide a standard method of obtaining data for research and development, quality control, acceptance or rejection under specifications, and special purposes. The tests cannot be considered significant for engineering design in applications differing widely from the load-time scale of the standard test. Such applications require additional tests such as impact, creep, and fatigue.

4.4 Before proceeding with this test method, reference should be made to the ASTM specification for the material being tested. Any test specimen preparation, conditioning, dimensions, and testing parameters covered in the materials

specification shall take precedence over those mentioned in this test method. If there is no material specification, then the default conditions apply. Table 1 in Classification D 4000 lists the ASTM materials standards that currently exist.

5. Apparatus

5.1 *Testing Machine*—Any suitable testing machine capable of control of constant-rate-of-crosshead movement and comprising essentially the following:

5.1.1 *Drive Mechanism*—A drive mechanism for imparting to the movable cross-head member, a uniform, controlled velocity with respect to the base (fixed member), with this velocity to be regulated as specified in Section 9.

5.1.2 *Load Indicator*—A load-indicating mechanism capable of showing the total compressive load carried by the test specimen. The mechanism shall be essentially free from inertia-lag at the specified rate of testing and shall indicate the load with an accuracy of $\pm 1\%$ of the maximum indicated value of the test (load). The accuracy of the testing machine shall be verified at least once a year in accordance with Practices E 4.

5.2 *Compressometer*—A suitable instrument for determining the distance between two fixed points on the test specimen at any time during the test. It is desirable that this instrument automatically record this distance (or any change in it) as a function of the load on the test specimen. The instrument shall be essentially free of inertia-lag at the specified rate of loading and shall conform to the requirements for a Class B-2 extensometer as defined in Practice E 83.

NOTE 3—The requirements for extensometers cited herein apply to compressometers as well.

5.3 *Compression Tool*—A compression tool for applying the load to the test specimen. This tool shall be so constructed that loading is axial within 1:1000 and applied through surfaces that are flat within 0.025 mm (0.001 in.) and parallel to each other in a plane normal to the vertical loading axis. Examples of suitable compression tools are shown in Fig. 1 and Fig. 2.

5.4 *Supporting Jig*—A supporting jig for thin specimens is shown in Fig. 3 and Fig. 4.

5.5 *Micrometers*—Suitable micrometers, reading to 0.01 mm or 0.001 in. for measuring the width, thickness, and length of the specimens.

6. Test Specimens

6.1 Unless otherwise specified in the materials specifications, the specimens described in 6.2 and 6.7 shall be used. These specimens may be prepared by machining operations from materials in sheet, rod, tube, or similar form, or they may be prepared by compression or injection molding of the material to be tested. All machining operations shall be done carefully so that smooth surfaces result. Great care shall be taken in machining the ends so that smooth, flat parallel surfaces and sharp, clean edges, to within 0.025 mm (0.001 in.) perpendicular to the long axis of the specimen, result.

6.2 The standard test specimen, except as indicated in 6.3-6.7, shall be in the form of a right cylinder or prism whose length is twice its principal width or diameter. Preferred specimen sizes are 12.7 by 12.7 by 25.4 mm (0.50 by 0.50 by

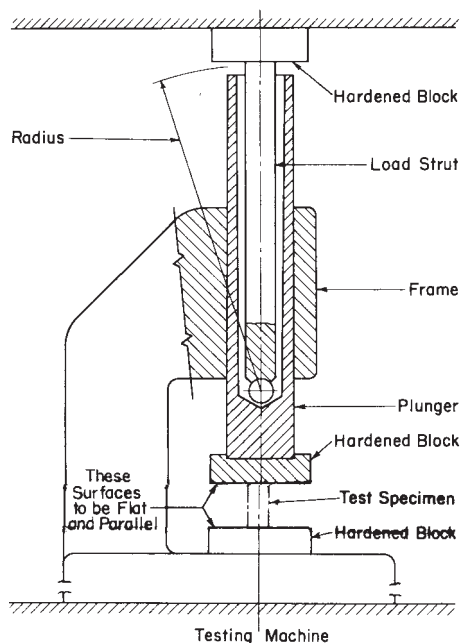

NOTE 1—Devices similar to the one illustrated have been successfully used in a number of different laboratories. Details of the device developed at the National Institute for Standards and Technology are given in the paper by Aitchinson, C. S., and Miller, J. A., "A Subpress for Compressive Tests," National Advisory Committee for Aeronautics, Technical Note No. 912, 1943.

FIG. 1 Subpress for Compression Tests

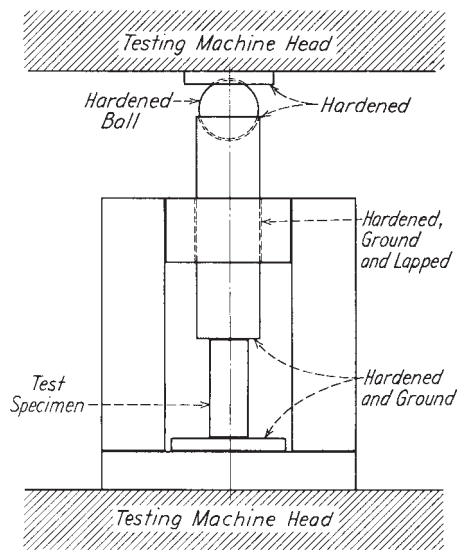

FIG. 2 Compression Tool

1 in.) (prism), or 12.7 mm in diameter by 25.4 mm (cylinder). Where elastic modulus and offset yield-stress data are desired, the test specimen shall be of such dimensions that the slenderness ratio is in the range from 11 to 16:1. In this case, preferred specimen sizes are 12.7 by 12.7 by 50.8 mm (0.50 by 0.50 by 2 in.) (prism), or 12.7 mm in diameter by 50.8 mm (cylinder).

6.3 For rod material, the test specimen shall have a diameter equal to the diameter of the rod and a sufficient length to allow a specimen slenderness ratio in the range from 11 to 16:1.

6.4 When testing tubes, the test specimen shall have a

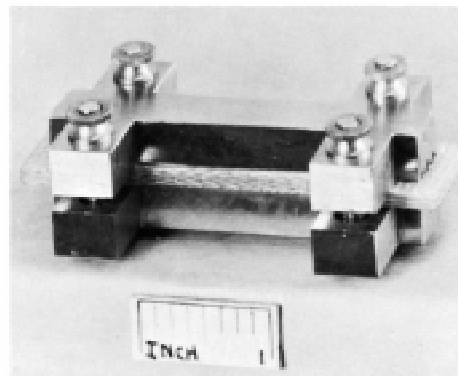

FIG. 3 Support Jig for Thin Specimen

diameter equal to the diameter of the tube and a length of 25.4 mm (1 in.) (Note 4). For crushing-load determinations (at right angles to the longitudinal axis), the specimen size shall be the same, with the diameter becoming the height.

NOTE 4—This specimen can be used for tubes with a wall thickness of 1 mm (0.039 in.) or over, to inside diameters of 6.4 mm (0.25 in.) or over, and to outside diameters of 50.8 mm (2.0 in.) or less.

6.5 Where it is desired to test conventional high-pressure laminates in the form of sheets, the thickness of which is less than 25.4 mm (1 in.), a pile-up of sheets 25.4 mm square, with a sufficient number of layers to produce a height of at least 25.4 mm, may be used.

6.6 When testing material that may be suspected of anisotropy, duplicate sets of test specimens shall be prepared having their long axis respectively parallel with and normal to the suspected direction of anisotropy.

6.7 *Reinforced Plastics, Including High-Strength Composites and High-Strength Composites and Highly Orthotropic Laminates*—The following specimens shall be used for reinforced materials, or for other materials when necessary to comply with the slenderness ratio requirements or to permit attachment of a deformation-measuring device.

6.7.1 For materials 3.2 mm (1/8 in.) and over in thickness, a specimen shall consist of a prism having a cross section of 12.7 mm (1/2 in.) by the thickness of the material and a length such that the slenderness ratio is in the range from 11 to 16:1 (Note 5).

6.7.2 For materials under 3.2 mm (1/8 in.) thick, or where elastic modulus testing is required and the slenderness ratio does not provide for enough length for attachment of a compressometer or similar device, a specimen conforming to that shown in Fig. 5 shall be used. The supporting jig shown in Fig. 3 and Fig. 4 shall be used to support the specimen during testing (Note 6).

NOTE 5—If failure for materials in the thickness range of 3.2 mm (1/8 in.) is by delamination rather than by the desirable shear plane fracture, the material may be tested in accordance with 6.7.2.

NOTE 6—Round-robin tests have established that relatively satisfactory measurements of modulus of elasticity may be obtained by applying a compressometer to the edges of the jig-supported specimen.

6.8 When testing syntactic foam, the standard test specimen shall be in the form of a right cylinder 25.4 mm (1 in.) in diameter by 50.8 mm (2 in.) in length.

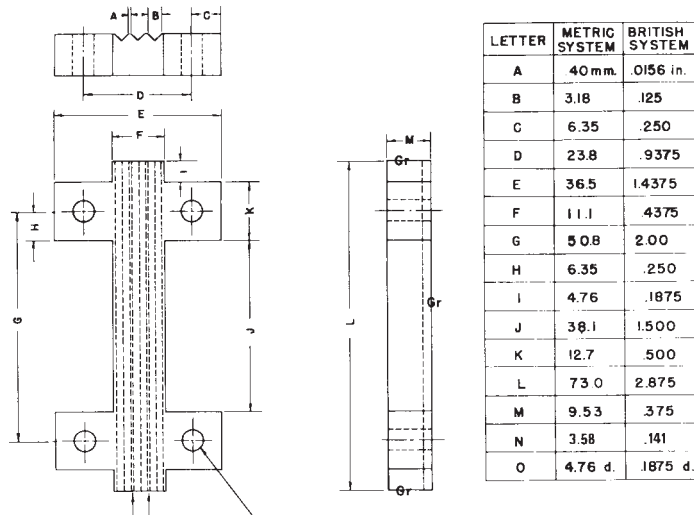

NOTE 1—Cold rolled steel.
 NOTE 2—Furnished four steel machine screws and nuts, round head, slotted, length 31.75 mm (1¼ in.).
 NOTE 3—Grind surfaces denoted “Gr.”

FIG. 4 Support Jig, Details

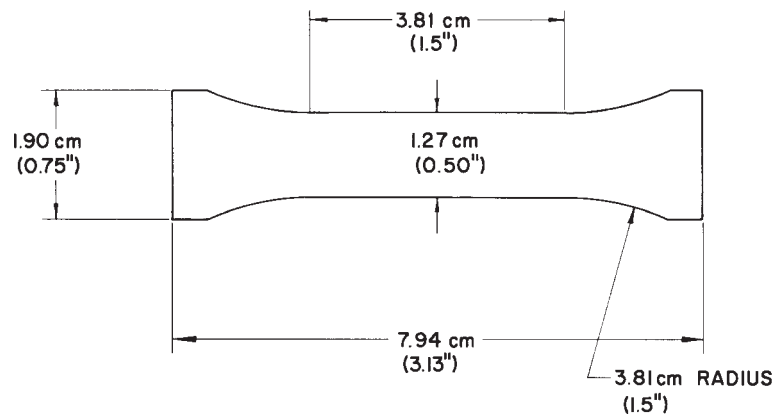

FIG. 5 Compression Test Specimen for Materials Less than 3.2 mm Thick

7. Conditioning

7.1 *Conditioning*—Condition the test specimens at $23 \pm 2^\circ\text{C}$ ($73.4 \pm 3.6^\circ\text{F}$) and $50 \pm 5\%$ relative humidity for not less than 40 h prior to test in accordance with Procedure A of Practice D 618 unless otherwise specified by contract or relevant ASTM material specification. Reference pre-test conditioning, to settle disagreements, shall apply tolerances of $\pm 1^\circ\text{C}$ (1.8°F) and $\pm 2\%$ relative humidity.

7.1.1 Note that for some hygroscopic materials, such as nylons, the material specifications (for example, Classification System D 4066) call for testing “dry as-molded specimens.” Such requirements take precedence over the above routine preconditioning to 50 % RH and require sealing the specimens in water vapor-impermeable containers as soon as molded and not removing them until ready for testing.

7.2 *Test Conditions*—Conduct the tests at $23 \pm 2^\circ\text{C}$ ($73.4 \pm 3.6^\circ\text{F}$) and $50 \pm 5\%$ relative humidity unless otherwise specified by contract or the relevant ASTM material specification. Reference testing conditions, to settle disagreements, shall apply tolerances of $\pm 1^\circ\text{C}$ (1.8°F) and $\pm 2\%$ relative humidity.

8. Number of Test Specimens

8.1 At least five specimens shall be tested for each sample in the case of isotropic materials.

8.2 Ten specimens, five normal to and five parallel with the principal axis of anisotropy, shall be tested for each sample in the case of anisotropic materials.

8.3 Specimens that break at some obvious flaw shall be discarded and retests made, unless such flaws constitute a variable, the effect of which it is desired to study.

9. Speed of Testing

9.1 Speed of testing shall be the relative rate of motion of the grips or test fixtures during the test. Rate of motion of the driven grip or fixture when the machine is running idle may be used if it can be shown that the resulting speed of testing is within the limits of variation allowed.

9.2 The standard speed of testing shall be 1.3 ± 0.3 mm (0.050 ± 0.010 in.)/min, except as noted in 10.5.4.

10. Procedure

10.1 Measure the width and thickness of the specimen to the

nearest 0.01 mm (0.001 in.) at several points along its length. Calculate and record the minimum value of the cross-sectional area. Measure the length of the specimen and record the value.

10.2 Place the test specimen between the surfaces of the compression tool, taking care to align the center line of its long axis with the center line of the plunger and to ensure that the ends of the specimen are parallel with the surface of the compression tool. Adjust the crosshead of the testing machine until it just contacts the top of the compression tool plunger.

NOTE 7—The compression tool may not be necessary for testing of lower modulus (for example, 700 MPa to 3500 MPa (100 000 psi to 500 000 psi)) material if the loading surfaces are maintained smooth, flat, and parallel to the extent that buckling is not incurred.

10.3 Place thin specimens in the jig (Fig. 3 and Fig. 4) so that they are flush with the base and centered (Note 8). The nuts or screws on the jig shall be finger tight (Note 9). Place the assembly in the compression tool as described in 5.3.

NOTE 8—A round-robin test, designed to assess the influence of specimen positioning in the supporting jig (that is, flush versus centered mounting), showed no significant effect on compressive strength due to this variable. However, flush mounting of the specimen with the base of the jig is specified for convenience and ease of mounting.⁸

NOTE 9—A round-robin test on the effect of lateral pressure at the supporting jig has established that reproducible data can be obtained with the tightness of the jig controlled as indicated.

10.4 If only compressive strength or compressive yield strength, or both, are desired, proceed as follows:

10.4.1 Set the speed control at 1.3 mm/min (0.050 in./min) and start the machine.

10.4.2 Record the maximum load carried by the specimen during the test (usually this will be the load at the moment of rupture).

10.5 If stress-strain data are desired, proceed as follows:

10.5.1 Attach compressometer.

10.5.2 Set the speed control at 1.3 mm/min (0.050 in./min) and start the machine.

10.5.3 Record loads and corresponding compressive strain at appropriate intervals of strain or, if the test machine is equipped with an automatic recording device, record the complete load-deformation curve.

10.5.4 After the yield point has been reached, it may be desirable to increase the speed from 5 to 6 mm/min (0.20 to 0.25 in./min) and allow the machine to run at this speed until the specimen breaks. This may be done only with relatively ductile materials and on a machine with a weighing system with response rapid enough to produce accurate results.

11. Calculation

11.1 *Compressive Strength*—Calculate the compressive strength by dividing the maximum compressive load carried by the specimen during the test by the original minimum cross-sectional area of the specimen. Express the result in megapascals or pounds-force per square inch and report to three significant figures.

11.2 *Compressive Yield Strength*—Calculate the compressive yield strength by dividing the load carried by the specimen

at the yield point by the original minimum cross-sectional area of the specimen. Express the result in megapascals or pounds-force per square inch and report to three significant figures.

11.3 *Offset Yield Strength*—Calculate the offset yield strength by the method referred to in 3.2.11.

11.4 *Modulus of Elasticity*—Calculate the modulus of elasticity by drawing a tangent to the initial linear portion of the load deformation curve, selecting any point on this straight line portion, and dividing the compressive stress represented by this point by the corresponding strain, measure from the point where the extended tangent line intersects the strain-axis. Express the result in gigapascals or pounds-force per square inch and report to three significant figures (see Annex A1).

11.5 For each series of tests, calculate to three significant figures the arithmetic mean of all values obtained and report as the “average value” for the particular property in question.

11.6 Calculate the standard deviation (estimated) as follows and report to two significant figures:

$$s = \sqrt{(\sum X^2 - n\bar{X}^2)/(n - 1)} \quad (1)$$

where:

s = estimated standard deviation,

X = value of single observation,

n = number of observations, and

\bar{X} = arithmetic mean of the set of observations.

NOTE 10—The method for determining the offset compressive yield strength is similar to that described in the Annex of Test Method D 638.

12. Report

12.1 Report the following information:

12.1.1 Complete identification of the material tested, including type, source, manufacturer’s code number, form, principal dimensions, previous history, etc.,

12.1.2 Method of preparing test specimens,

12.1.3 Type of test specimen and dimensions,

12.1.4 Conditioning procedure used,

12.1.5 Atmospheric conditions in test room,

12.1.6 Number of specimens tested,

12.1.7 Speed of testing,

12.1.8 Compressive strength, average value, and standard deviation,

12.1.9 Compressive yield strength and offset yield strength average value, and standard deviation, when of interest,

12.1.10 Modulus of elasticity in compression (if required), average value, standard deviation,

12.1.11 Date of test, and

12.1.12 Date of test method.

13. Precision and Bias⁹

13.1 Table 1 and Table 2 are based on a round-robin test conducted in 1987 in accordance with Practice E 691, involving three materials tested by six laboratories for Test Method D 695M. Since the test parameters overlap within tolerances and the test values are normalized, the same data are used for both test methods. For each material, all of the samples were

⁸ Supporting data are available from ASTM Headquarters. Request RR: D20-1061.

⁹ Supporting data are available from ASTM Headquarters, Request RR: D20-1150.

TABLE 1 Precision, Compressive Strength
(Values in Units of Megapascals)

Material	Average	S_r^A	S_R^B	r^C	R^D
Acetal	100	1.1	2.1	3.1	5.9
Polystyrene	106	1.4	3.5	3.9	9.8
Linen-filled phenolic	158	3.7	7.5	10.4	21.0

^A S_r is the within-laboratory standard deviation for the indicated material. It is obtained by pooling the within-laboratory standard deviations of the test results from all of the participating laboratories:

$$S_r = [((S_1)^2 + (S_2)^2 + \dots + (S_n)^2)/n]^{1/2}$$

^B S_R is the between-laboratories reproducibility, expressed as a standard deviation, for the indicated material.

^C r is the within-laboratory repeatability limit, $r = 2.8 \times S_r$.

^D R is the between-laboratory reproducibility limit, $R = 2.8 \times S_R$.

TABLE 2 Precision, Compressive Modulus
(Values in Units of Megapascals)

Material	Average	S_r^A	S_R^B	r^C	R^D
Acetal	3.28	0.14	0.25	0.39	0.70
Polystyrene	3.88	0.07	0.74	0.20	2.07
Linen-filled phenolic	6.82	0.23	0.90	0.64	2.52

^A S_r is the within-laboratory standard deviation for the indicated material. It is obtained by pooling the within-laboratory standard deviations of the test results from all of the participating laboratories:

$$S_r = [((S_1)^2 + (S_2)^2 + \dots + (S_n)^2)/n]^{1/2}$$

^B S_R is the between-laboratories reproducibility, expressed as a standard deviation, for the indicated material.

^C r is the within-laboratory repeatability limit, $r = 2.8 \times S_r$.

^D R is the between-laboratory reproducibility limit, $R = 2.8 \times S_R$.

prepared at one source. Each test result was the average of five individual determinations. Each laboratory obtained two test results for each material.

NOTE 11—Caution: The following explanations of r and R (13.2-13.2.3) are only intended to present a meaningful way of considering the approximate precision of this test method. The data in Table 1 and Table

2 should not be rigorously applied to acceptance or rejection of material, as these data apply only to the materials tested in the round robin and are unlikely to be rigorously representative of other lots, formulations, conditions, materials, or laboratories. Users of this test method should apply the principles outlined in Practice E 691 to generate data specific to their laboratory and materials or between specific laboratories. The principles of 13.2-13.2.3 would then be valid for such data.

13.2 *Concept of r and R in Table 1 and Table 2*—If $S(r)$ and $S(R)$ have been calculated from a large enough body of data, and for test results that were averages from testing of five specimens for each test result, then:

13.2.1 *Repeatability*—Two test results obtained within one laboratory shall be judged not equivalent if they differ by more than the “ r ” for that the material. “ r ” is the interval representing the critical difference between two test results for the same material, obtained by the same operator using the same equipment on the same day in the same laboratory.

13.2.2 *Reproducibility, R* —Two test results obtained by different laboratories shall be judged not equivalent if they differ by more than the “ R ” value for that material. “ R ” is the interval representing the critical difference between the two test results for the same material, obtained by different operators using different equipment in different laboratories.

13.2.3 Any judgement in accordance with 13.2.1 and 13.2.2 would have an approximate 95 % (0.95) probability of being correct.

13.3 There are no recognized standards by which to estimate the bias of this test method.

14. Keywords

14.1 compressive properties; compressive strength; modulus of elasticity; plastics

ANNEX

(Mandatory Information)

A1. TOE COMPENSATION

A1.1 In a typical stress-strain curve (Fig. A1.1) there is a toe region, AC , that does not represent a property of the material. It is an artifact caused by a take-up of slack, and alignment or seating of the specimen. In order to obtain correct values of such parameters as modulus, strain, and offset yield point, this artifact must be compensated for to give the corrected zero point on the strain or extension axis.

A1.2 In the case of a material exhibiting a region of Hookean (linear) behavior (Fig. A1.1), a continuation of the linear (CD) region of the curve is constructed through the zero-stress axis. This intersection (B) is the corrected zero-strain point from which all extensions or strains must be measured, including the yield offset (BE), if applicable. The elastic modulus can be determined by dividing the stress at any

point along the line CD (or its extension) by the strain at the same point (measured from Point B , defined as zero-strain).

A1.3 In the case of a material that does not exhibit any linear region (Fig. A1.2), the same kind of toe correction of the zero-strain point can be made by constructing a tangent to the maximum slope at the inflection point (H'). This is extended to intersect the strain axis at Point B' , the corrected zero-strain point. Using Point B' as zero strain, the stress at any point (G') on the curve can be divided by the strain at that point to obtain a secant modulus (slope of line $B'G'$). For those materials with no linear region, any attempt to use the tangent through the inflection point as a basis for determination of an offset yield point may result in unacceptable error.

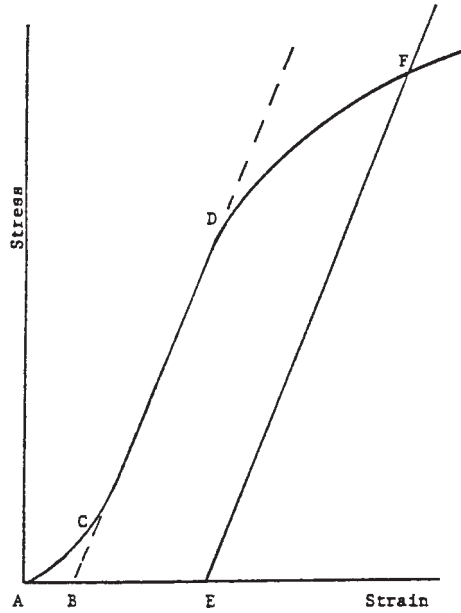

NOTE 1—Some chart recorders plot the mirror image of this graph.

FIG. A1.1 Material with Hookean Region

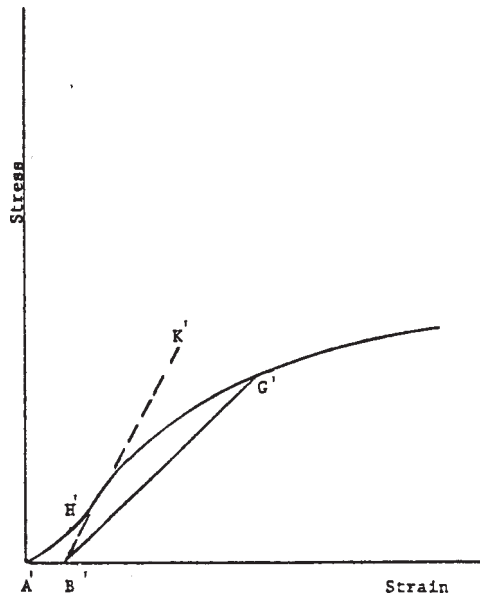

NOTE 1—Some chart recorders plot the mirror image of this graph.

FIG. A1.2 Material with No Hookean Region

SUMMARY OF CHANGES

This section identifies the location of selected changes to this test method. For the convenience of the user, Committee D20 has highlighted those changes that may impact the use of this test method. This section may also include descriptions of the changes or reasons for the changes, or both.

D695-02a:

- (1) Added Terminology D 883.
- (2) Added Test Methods D 5947.
- (3) Added 3.1, adjusted numbering throughout Section 3.
- (4) Changed reference in 3.2.8 from 3.11 to 3.2.11.
- (5) Deleted last sentence of 4.1.
- (6) Added last sentence to 4.4.
- (7) Reworded 5.1.1 to improve readability

(8) Changed “fortuitous flow” to “flaw” in 8.3.

(9) Reworded Note 11, 13.2, 13.2.1, and 13.2.2 to be in accordance with Guide D 4968.

(10) Corrected the title of Fig. 3.

D695–02:

(1) Revised 7.1 and 7.2.

ASTM International takes no position respecting the validity of any patent rights asserted in connection with any item mentioned in this standard. Users of this standard are expressly advised that determination of the validity of any such patent rights, and the risk of infringement of such rights, are entirely their own responsibility.

This standard is subject to revision at any time by the responsible technical committee and must be reviewed every five years and if not revised, either reapproved or withdrawn. Your comments are invited either for revision of this standard or for additional standards and should be addressed to ASTM International Headquarters. Your comments will receive careful consideration at a meeting of the responsible technical committee, which you may attend. If you feel that your comments have not received a fair hearing you should make your views known to the ASTM Committee on Standards, at the address shown below.

This standard is copyrighted by ASTM International, 100 Barr Harbor Drive, PO Box C700, West Conshohocken, PA 19428-2959, United States. Individual reprints (single or multiple copies) of this standard may be obtained by contacting ASTM at the above address or at 610-832-9585 (phone), 610-832-9555 (fax), or service@astm.org (e-mail); or through the ASTM website (www.astm.org).
