

RTN...

Load cell

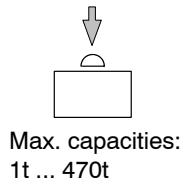

Special features

- Low construction
- Legal for trade according to OIML up to 5000 d and MI up to 7500 d
- Stainless steel
- Protection class IP 68
- High output signal of 2.85 mV/V
- Input resistance >4400 Ω

Available options:

- Explosion proof version EEx ib IIC T6
- Service temperature range (B_{tu}) up to +110°C.

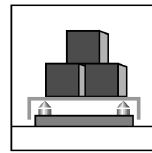
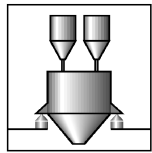
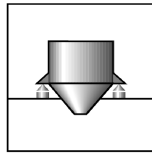
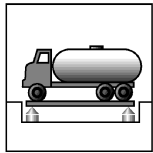

Dimensions (in mm; 1mm = 0.03937 inches):

RTN... / ≤4.7t

(1) L = Cable length

RTN... / 10t - 470t

Wiring code RTN... / 1t - 470t

RTN...	1t	2.2t	4.7t	10t	15t	22t	33t	47t	68t	100t	150t	220t	330t	470t
ØA	49	49	49	74	75	75	95	130	130	150	150	225	225	270
ØB	20	20	20	30	30	30	40	60	60	70	70	100	100	120
ØC	60	60	60	75	75	75	95	130	130	150	150	225	225	270
H	43	43	43	50	50	50	65	75	85	90	100	130	145	170
J	-	-	-	7	7	7	7	7	7	7	7	10	10	10
K	7.5	7.5	7.5	6.5	6.5	6.5	10	14	14	16	16	24	24	28
L	5m	5m	5m	5m	5m	12m	12m	12m	12m	12m	5m	5m	5m	5m

Technical data

Type / Maximum capacity (E_{max})		RTN 0.1 / 1t ... 470t RTN 0.05 / 1t ... 470t RTN C3 / 1t ... 470t			RTN C4 / 1t ... 100t RTN C5 / 1t ... 100t RTN C3 MI 7.5 / 1t ... 100t ¹⁾			
Accuracy class		0.1	0.05	C3 (OIML R60)	C4 (OIML R60)	C5 (OIML R60)	C3 Mi 7.5 (OIML R60)	
Maximum number of load cell intervals (n_{LC}) [for Multi-interval scales]		-	-	3000	4000	5000	3000 [7500]	
Minimum LC verification interval (v_{min})	% of E_{max}	-	-	0.005 (= $E_{max} / 20000$)	0.00417 (= $E_{max} / 24000$)			
Sensitivity (C_n)	mV/V	2.85 ±0.3%			2.85 ±0.1%			
Temperature effect on sensitivity (TK_C)	% of C_n / 10K	±0.1	±0.05	±0.008 ²⁾	±0.007 ²⁾	±0.0062 ²⁾	±0.007 ²⁾	
Temperature effect on zero balance (TK_0)		±0.1	±0.03	±0.007	±0.0058	±0.0058	±0.0058	
Hysteresis error (d_{hy})	% of C_n	0.1	0.05	0.02 ²⁾	0.015 ²⁾	0.01 ²⁾	0.013 ²⁾	
Non-linearity (d_{lin})		0.1	0.05	0.02 ²⁾	0.015 ²⁾	0.01 ²⁾	0.013 ²⁾	
Creep (d_{cr}) over 30 min.		±0.05	±0.03	±0.017	±0.012	±0.01	±0.007	
Input resistance (R_{LC})	Ω	4450 ±100						
Output resistance (R_0)		4010 ±10	4010 ±2	4010 ±0.5				
Reference excitation voltage (U_{ref})	V	5						
Nominal range of excitation voltage (B_U)		5 ... 30 (max. 60)						
Insulation resistance (R_{is})	GΩ	> 20						
Nominal temperature range (B_T)	°C[°F]	-10 ... +40 [+14 ... +104]						
Service temperature range (B_{tu})		-40 ... +80 [-40 ... +176] (Option: up to +110°C / +230°F)						
Storage temperature range (B_{tl})		-50 ... +85 [-58 ... +185]						

Maximum capacity (E_{max})	t	1	2.2	4.7	10	15	22	33	47	68	100	150	220	330	470
Weight (G), approx.	kg	0.6	0.6	0.7	1.2	1.3	1.3	2.1	4.3	4.8	7.0	8.6	22	29	50
Safe load limit (E_L)	t	1.7	3.8	8	17	25	38	56	80	115	170	250	380	500	700
Breaking load (E_d)		4	9	19	40	60	88	130	190	270	400	600	770	1100	1500
Permissible static side load (L_q)		0.5 ($E_{max} - 0.8 L_z$), but no higher than $L_{q max} = 0.3 E_{max}$ (E_{max} = maximum capacity; L_z = load in measuring direction)													
Permissible dynamic load (F_{srel}) (vibration amplitude according to DIN 50100)	% of E_{max}	70													
Deflection at E_{max} (s_{nom}), approx.	mm	0.13	0.12	0.12	0.17	0.18	0.21	0.25	0.33	0.35	0.45	0.57	0.67	0.85	1.00
Protection class according to EN60529 (IEC529)		IP 68													
Material: Measuring element Cable fitting Cable-sheath		Stainless steel Brass, nickel plated / Sealing: CR/NBR Special silikon, RAL 7000 (grey), Ø6.5mm													

1) On request also deliverable: **RTN C4 MI 7.5 / 1t ... 100t**.

2) The data for Non-linearity (d_{lin}), Hysteresis error (d_{hy}) and Temperature effect on sensitivity (TK_C) are typical values. The sum of these data meets the requirements according to OIML R60.

Options:

- Explosion proof version for use according to declaration of conformity in intrinsically safe circuits of the group **EEx ib IIC T6**.
- Service temperature range (B_{tu}) up to +110°C.

Accessory: **Pendulum mounts VPN** (Dimensions in mm; 1mm = 0.03937 inches)

RTN / ...t / VPN (Pendulum mounts for Load cells RTN... / 1t - 100t)

Material: Stainless steel

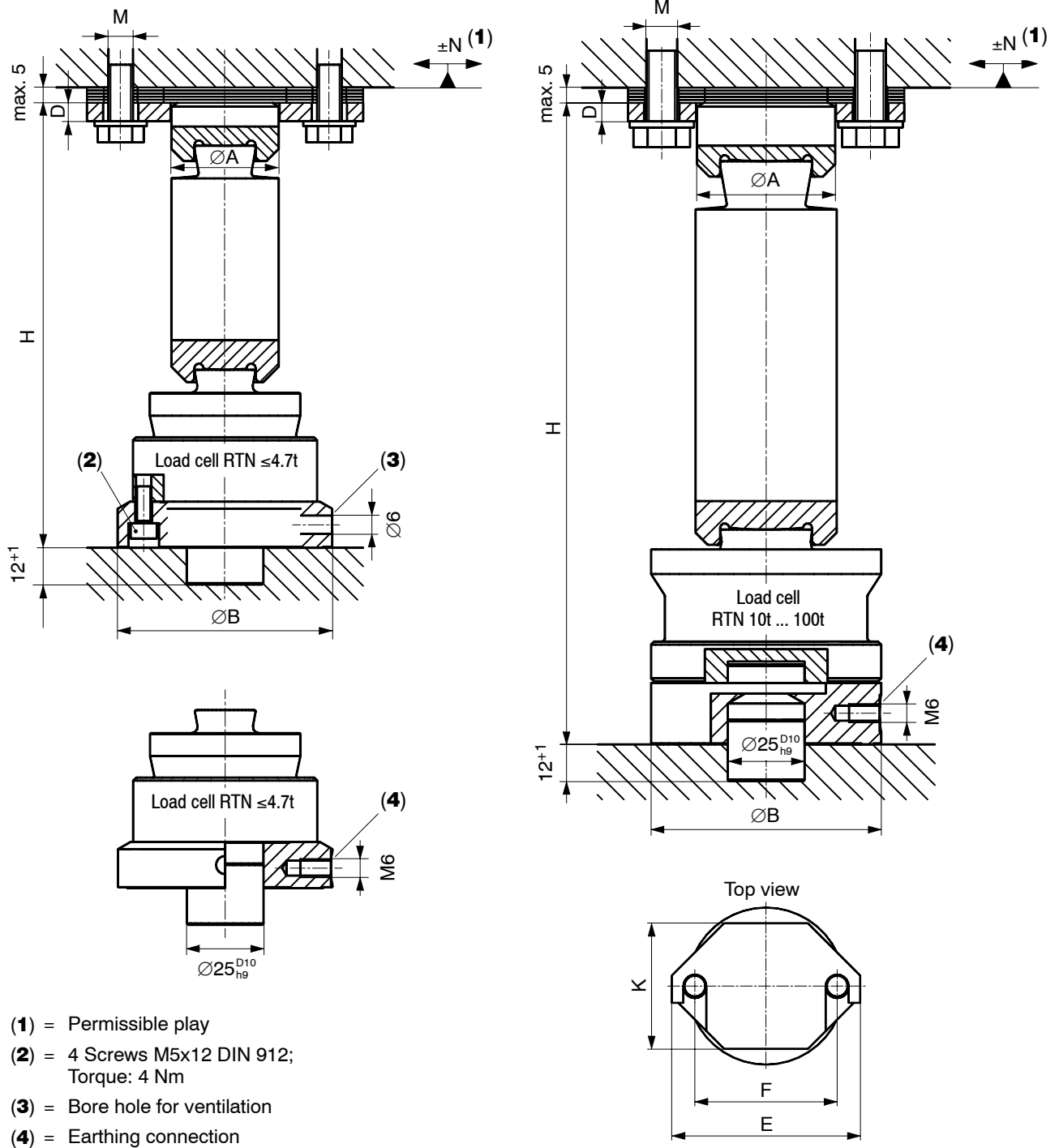

Type (E_{max} LC)	ØA	ØB	D	E	F	H	K	M	N
RTN/2.2t/VPN (1t + 2.2t)	35	70	6	90	68	128	60	M8 x 20	3.5
RTN/4.7t/VPN (4.7t)	35	70	6	90	68	145	60	M8 x 20	3.5
RTN/10t/VPN (10t)	45	75	6	90	68	165	60	M10 x 25	3.5
RTN/15t/VPN (15t)	45	75	6	90	68	175	60	M10 x 25	4
RTN/22t/VPN (22t)	45	75	6	90	68	229	60	M10 x 25	7
RTN/33t/VPN (33t)	58	95	6	120	90	272	80	M12 x 25	7
RTN/47t/VPN (47t)	85	130	10	170	130	295	110	M16 x 30	6
RTN/68t/VPN (68t)	85	130	10	170	130	337	110	M16 x 30	7
RTN/100t/VPN (100t)	100	150	10	180	140	371	130	M16 x 30	8

Accessory: **Elastomer mounts VEN** (Dimensions in mm; 1mm = 0.03937 inches)

RTN / 4.7t / VEN (Elastomer mounts for Load cells RTN... / ≤4.7t)

Material: Stainless steel; Elastomer = Neoprene (chlorine butadiene rubber)

Deflection <0.8mm (at 4.7t)

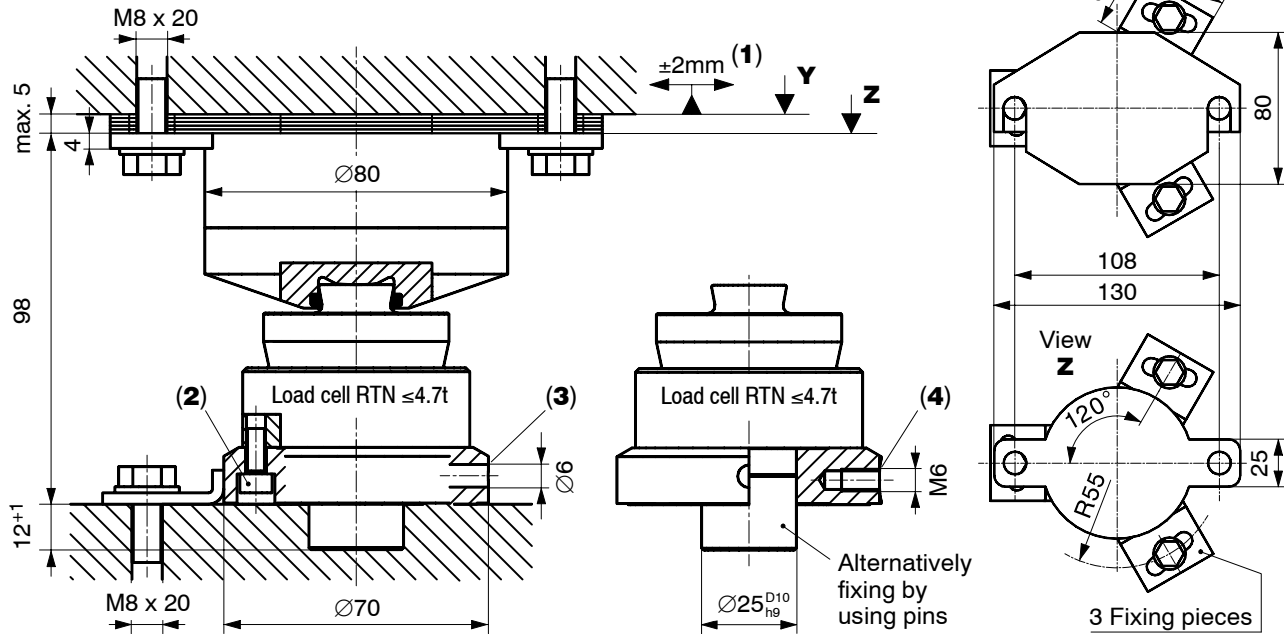

RTN / ...t / VEN (Elastomer mounts for Load cells RTN... / 10t - 100t)*

Material: Galvanized steel; Elastomer = Neoprene (chlorine butadiene rubber)

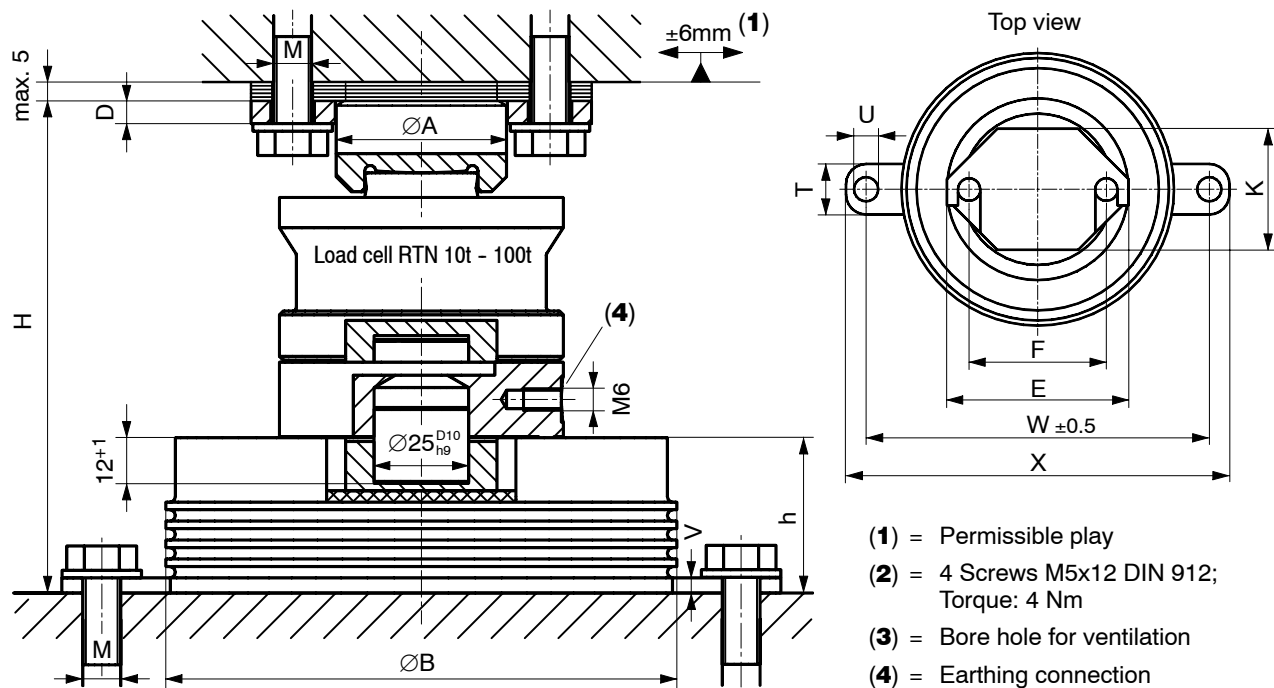

- (1) = Permissible play
- (2) = 4 Screws M5x12 DIN 912; Torque: 4 Nm
- (3) = Bore hole for ventilation
- (4) = Earthing connection

Type (E _{max} LC)	Deflection	ØA	ØB	D	E	F	H	h	K	M	T	ØU	V	W ±0.5	X
RTN/22t/VEN (10t-22t)	0.5 (at 22t)	45	135	6	90	68	130	41	60	M10x25	25	12	4	170	190
RTN/33t/VEN (33t)	0.8	58	175	6	120	90	168	56	80	M12x25	30	17	6	250	280
RTN/47t/VEN (47t)	0.5	85	250	10	170	130	198	63	110	M16x30	40	21	8	310	350
RTN/68t/VEN (68t)	0.7	85	250	10	170	130	220	63	110	M16x30	40	21	8	310	350
RTN/100t/VEN (100t)	0.6	100	300	10	180	140	239	68	130	M16x30	40	21	8	360	400

* Elastomer mounts VEN for higher capacities on request



Hottinger Baldwin Messtechnik GmbH
 Im Tiefen See 45, D-64293 Darmstadt, Germany
 Tel.: +49 (0)6151 / 803 0; Fax: +49 (0)6151 / 803 9 100
 www.hbm.com; e-mail: support@hbm.com

Modifications reserved.
 All details describe our products in general form. They are not to be understood as express warranty and do not constitute any liability whatsoever.