



- p_{max} : 10 bar;
 t_{max} : 100 °C
 (150 °C for CIP process)
- Process connection: G 1/2, installation meets hygiene standards through EHEDG-certified installation system LZE
- Materials approved for handling of foodstuffs
- Independent of the conductivity of the medium
- Optimum flow geometry



Weld-in sleeve LZE



KOBOLD companies worldwide:

ARGENTINA, AUSTRIA, BELGIUM, CANADA, CHILE, CHINA, CZECH REPUBLIC, FRANCE, GERMANY, GREAT BRITAIN, INDONESIA, ITALY, MALAYSIA, MEXICO, NETHERLANDS, PERU, POLAND, SWITZERLAND, SINGAPORE, SLOVAKIA, THAILAND, USA, VENEZUELA, VIETNAM

KOBOLD Messring GmbH
 Nordring 22-24
 D-65719 Hofheim/Ts.
 ☎ Zentrale: +49(0)61 92 299-0
 ☎ Vertrieb DE: +49(0)61 92 299-500
 Fax +49(0)61 92 23398
 E-Mail: info.de@kobold.com

Model:
 LNZ



Description:

The LNZ capacitive level switch is used for detecting levels of fill. The electric field penetrates several millimetres into the medium. The change in capacity caused by contact with the medium is measured and evaluated.

By using this principle of measurement it is also possible to detect non-conductive media. Installation in tanks is very straightforward regardless of position.

In combination with the KOBOLD LZE or LZE-R weld-in sleeves, the probe provides a measuring point that has no dead space and meets hygiene standards and (EHEDG approval certificate). Installation is virtually front-flush. This level switch is therefore very well suited for CIP/SIP cleaning. Adapter sleeves are also available for different process connections so that the device can also be used in existing systems.

Because the electronics are already integrated no other evaluating instrument is necessary. The output signal (24 V_{DC}) can therefore be transmitted direct to an SPS for further processing.

Applications areas:

- Level monitoring, also in non-conductive media
- not with deposits
- Safe level monitoring, even with foam

Technical data:

- Measuring principle: capacitive
- Process temperature: 0...100 °C
150 °C max. 30 min for CIP process
- Ambient temperature: 0...70 °C
- Working pressure: max. 10 bar
- Material
 - Head, thread supports: stainless steel 1.4404
 - Coupler section: PEEK
- Process connection: G 1/2, hygienic weld-in sleeve LZE, LZE-R (see page xxxx)
- Connection: threaded cable connection M16 x 1.5
Terminal: 3-pole, (optional plug M12 x1)
- Function: Full/empty report (determined via the polarity of the supply voltage)
- Output: Open Collector, PNP, max. 200 mA
- Switch delay (fixed): approx. 0.2 s
- Power supply: 24 V_{DC} ± 20 %, < 10 mA without load
- Protection: IP 67
- Weight: approx. 0.5 kg
- Dielectric constant of the medium: $\epsilon_r > 20$

Dimensions

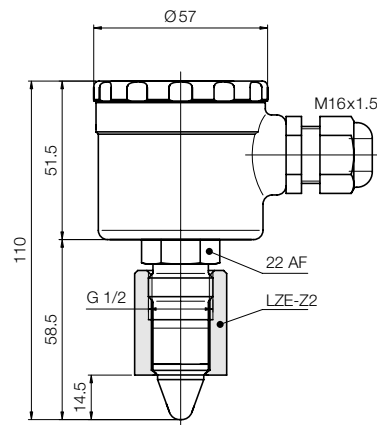

Order data (Example order: LNZ-12 G4 3PK)

Model	Material	Process connection	Electrical connection
LNZ-	12 = stainless steel	G4 = G 1/2	3PK = M16x1.5 threaded cable connection 3PS = M12x1 plug

EHEDG certification of the connection system in combination with weld-in sleeve LZE (see Page 000)