

Mechanical Pressure Switches

for overpressure, vacuum pressure
and differential pressure

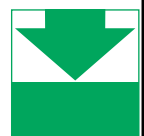

- Switching range:
-250 ... +100 mbar,
1 ... 16 mbar to 16 ... 63 bar
- Temperature:
max. 70°C
- Material:
Copper, brass,
stainless steel, NBR
- Connection: G 1/2



KOBOLD offices exist in the following countries:

ARGENTINA, AUSTRIA, BELGIUM, BRAZIL, CANADA,
CHINA, COLOMBIA, FRANCE, GREAT BRITAIN, NETHERLANDS,
POLAND, SWITZERLAND, USA, VENEZUELA

KOBOLD Messring GmbH
Nordring 22-24
D-65719 Hofheim/Ts.
☎ (06192) 299-0
Fax (06192) 23398
E-mail: info.de@kobold.com
Internet: www.kobold.com

Model:
SCH

Pressure switches General description



Mode of operation

The pressure applied in the sensor housing (1) acts on the measuring bellows (2). Pressure changes lead to movements of the measuring bellows (2) which are transferred through a pressure pin (4) to the switching rocker (5). The switching rocker is supported on hardened pivot points (6). As the pressure increases the switching rocker (5) moves upwards and operates the microswitch (7). The spring (8), the initial stress of which can be changed by the setting screw (9) (switching point setting), acts as opposing force. The traveling nut (10) is moved by turning the setpoint spindle, and the initial stress of the spring (8) is changed. The screw (11) serves for the internal adjustment of the microswitch. The counterpressure spring (12) ensures stable switching behaviour, even for low setting values.

- 1 = pressure connection
- 2 = measuring bellows
- 3 = sensor housing
- 4 = pressure pin
- 5 = switching rocker
- 6 = pivot points
- 7 = microswitch or other switching elements
- 8 = setpoint spring
- 9 = setting spindle (switching point setting)
- 10 = traveling nut (switching point indicator)
- 11 = adjusting screw for microswitch
- 12 = counterpressure spring

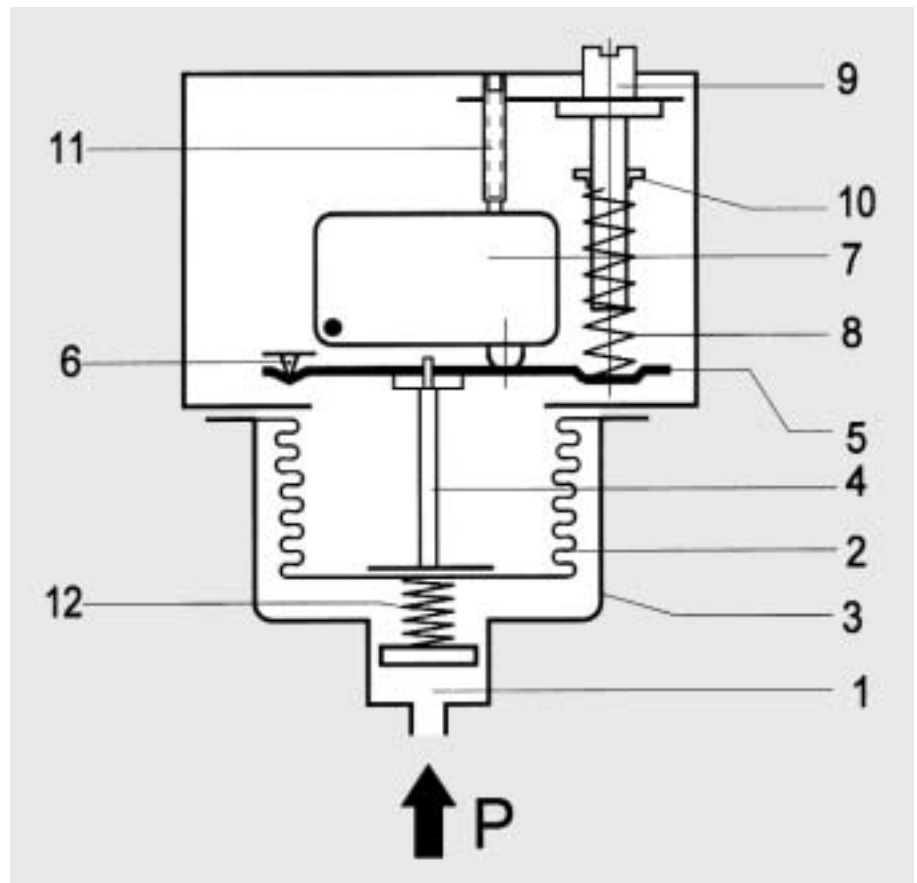

Pressure sensors

With few exceptions in the low pressure range, all pressure sensors are equipped with measuring bellows, partly made of a copper alloy but mostly in high stainless steel quality (1.4571). In comparison with the permissible values, the measuring bellows are subject to low loads and move only slightly. This results in long service life with low switching point drift and high overpressure safety. The movement of the measuring bellows is also restricted by an international stop so that the forces resulting from the overpressure can not be transmitted to the switching mechanism.

The parts of the sensor in contact with the medium are welded together without additional materials and the sensor contain no seals. Cu bellows which are used for low pressure ranges are soldered to the sensor housing. The sensor housing and all parts in the unit in contact with the medium can also be manufactured completely in stainless steel 1.4571 (series DNS). The individual data sheets contain exact data on materials.

Pressure connection

The pressure connection is designed in accordance with DIN 16288 for all pressure switches (pressure gauge connection G 1/2 A). They can also be connected optionally to the internal thread G 1/4 in accordance with ISO 228 Part 1. The centering pin must then be removed. Max. screw-down depth on the internal thread G 1/4 = 9 mm. When connected to the external thread G 1/2 with seal in the thread (i.e. without the sealing washer customary in the pressure gauge connection), the centering pin must be removed. Differential pressure switches have two pressure connections (max. and min.) and must be connected to one internal thread G 1/4 each.

The most important technical data



Valid for all pressure switch with microswitches of the DCM, VCM, DNM, DNS, DDC series.
The technical data of the component tested units deviate partly slightly.
(Please refer to type sheet)

Normal version

Ex-version



Switch housing

Aluminium diecast GD Al Si 12

Aluminium diecast GD Al Si 12

Pressure connection

G 1/2 external thread (pressure gauge connection) and G 1/4 internal thread.
Internal thread G 1/4 at differential pressure switches DDCM.

Switching function and connection drawing (applies only for version with microswitch)

Floating change-over contact.
With rising pressure switching over single-pole from 3-1 to 3-2

Floating change-over contact.
With rising pressure switching over single-pole from 3-1 to 3-2

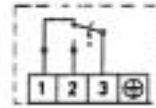
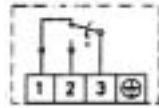

Switching capacity (applies only for version with microswitch)

8 A at 250 V_{AC}
5 A at 250 V_{AC} inductive
8 A at 24 V_{DC}
0.3 A at 250 V_{DC}

3 A at 250 V_{AC}
2 A at 250 V_{AC} inductive
3 A at 24 V_{DC}
0.03 A at 250 V_{DC}

Installation position

Arbitrary preferably vertical
See data sheet

Vertical

Degree of protection (in vertical position)

IP 54 (on request IP 65 by ZF 351)

IP 65

Ex degree of protection

-

Eex de IIC T6 tested to EN 50014/50018/50019 (CENELEC)

PTB approval

-

Ex 90.C.1059

Electrical connection

Plug connection (200 series) or Terminal connection (300 series)

Terminal connection

Cable entry

Pg 11

Pg 11

Ambient temperature

See data sheets

-15 to +60 °C

Switching point

Adjustable on the spindle.
In switching mechanism 300 the terminal box lid must be removed.

Adjustable on the spindle after the terminal box is removed.

Switching difference

Adjustable or not adjustable (see type overview)

Not adjustable

Medium temperature

Max. 70 °C, briefly 85 °C

Max. 60 °C

Higher medium temperatures are possible if the above limit values at the switching mechanism are ensured by suitable measures (e.g. siphon)

Vacuum

All pressure switches can operate under vacuum, the device is not damaged by this.

Repetition accuracy of the switching points

< 1% of the working range (for pressure ranges > 1 bar)

Vibration strength

Upto 4 g no noteworthy deviations.
The switching difference is reduced slightly at higher accelerations.
Use able 25 g not permissible.

Mechanical life

With sinusoidal pressure application and room temperature, 10 x 10⁶ switching cycles.
The expected life depends strongly upon the type of pressure application, therefore this figure can serve only as rough estimate.
With pulsating pressure or pressure impacts in hydraulic systems, pressure surge reduction is recommended.

Insulation values

Overvoltage category III, contamination class 3, reference surge voltage 4000 V.
The conformity to DIN VDE 0110 (01.89) will be confirmed.

Oil and grease-free

The parts of all pressure switches in contact with the medium are oil and grease-free.
The sensors are hermetically encapsulated, they contain no seals.

Description

Connection diagrams

Explanation

Normal version
 microswitch, single pole switching over,
 switching differential not adjustable

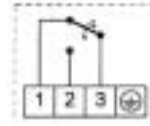

ZF 205

Maximum limiter
 with manual reset device.
 Interlocking with increasing pressure.

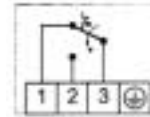

ZF 206

Minimum limiter
 with manual reset device.
 Interlocking with falling pressure.

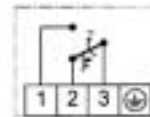

ZF 307

Two microswitches, switching in parallel
 or in succession. Fixed switching interval.
 Terminal connection case

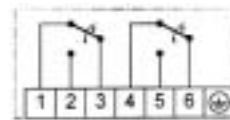

ZF 217

Two microswitches,
 switching in succession,
 1 plug adjustable switching interval.

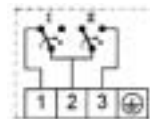

ZF 213

Gilded contacts
 Cannot be supplied with
 adjustable switching differential.

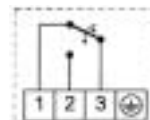

Switching capacity
 max. 24 V_{DC}, 100 mA
 min. 5 V_{DC}, 2 mA

Adjustment according to customer's instruction:

- one switching point
- two switching points or defined switching differential

Adjustment and sealing according customer's instruction:

- one switching point
- two switching points or defined switching differential

Specify the
 switching point
 and the
 direction of
 action

Special packing for oil- and grease-free storage



Pressure switches with special equipment can also be used in the **Ex area \geq Zone 1**.

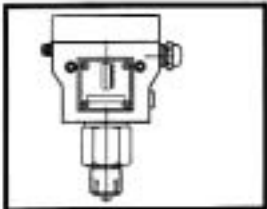

The following alternatives are possible:

1. Pressure switch with pressure-proof encapsulated switching device, degree of protection EEx de IIC T6.

The pressure switch in pressure-proof encapsulation can be used directly in the Ex area (\geq Zone 1). Maximum switching voltage, switching capacity and ambient temperature must be taken into account and the rules for the installation in the Ex area must be observed.

All pressure switches can be equipped with Ex switching mechanisms.

Special circuits as well as versions with adjustable switching differences are not possible.

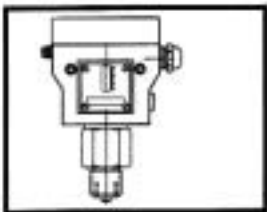

2. Pressure switches in EEx-i-version

All pressure switch in normal version can be used in the Ex area \geq Zone 1 if they are incorporated in an "intrinsically safe circuit". In principle the intrinsic safety is based on that fact that the control circuit run in the Ex area carries only a small amount of energy which is not able to generate ignitable sparks.

Isolating switching amplifiers, e.g. Type REL-6000 must be tested by the PTB and approved for Ex-installations.

Isolating switching amplifiers must be in any event installed outside the Ex zone.

Pressure switches which are intended for EEx-ia installations can be equipped with blue terminals and cable entries. Because of the low voltages and currents which are carried by the contacts of the microswitch, gold plated contacts are recommended (additional function ZF 513).

Order Example

SCH-DCM 6 - 205

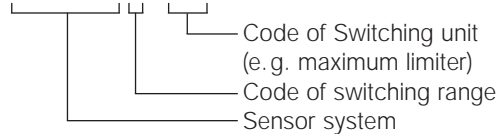

Order specification:

Pressure switch

SCH-DCM-6-205

or

SCH-DCM 6 with ZF 205

VdTÜV
Pressure 100/1

Steam and hot water

Pressure monitors and pressure limiters for steam and hot water in systems to DIN 4751 P2 and TRD 604. Series DA and DWR.

DVGW
DIN 3398 T.1 and 3

Fuel gases CE

Pressure monitors and limiters for fuel gases in accordance with DVGW Worksheet G-260. Series DGM and DWR.

TÜV
DIN 3398 T.4

Liquid fuels

Pressure monitors and pressure limiters for liquid fuels (heating oil). Serie DWR.

TÜV
Pressure 100/1 + DIN 3398 T.4

Pressure limiters in safety engineering

For safety-relevant pressure monitoring in liquid gas systems, chemical and processing engineering systems.

EEx de II CT6
(pressure proof encapsulated)

Ex-versions

For Ex areas \geq Zone 1, all pressure switches can be delivered in pressure-proof encapsulated design (Ex degree of protection EEx de II C T6). PTB approval: Ex 90.C.1059

EEx-ia
(intrinsically safe)

For intrinsically safe control circuits (Ex degree of protection EEx-ia), the pressure switches can be delivered with gold contacts, proximity switches as well as with the blue terminals and cable entries customary in the EEx-i area. An isolating switching amplifier, which transfer the control commands of the pressure switch form an intrinsically safe control circuit (EEx-ia) into a not intrinsically safe active circuit, is required in addition to the pressure switch.

Switch housing with switching mechanisms

The switch housings consist of high quality and seawater-resistant aluminium diecastings. Three versions are available:

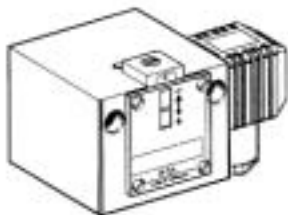

IP 54

Housing (normal version)

Plug connections to DIN 43650
Degree of protection IP 54
Setpoint setting accessible from the outside.

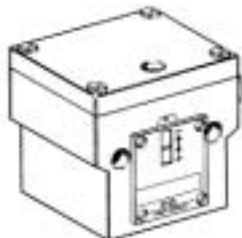

IP 54
(IP 65)

Terminal connection

With terminal connection box
Degree of protection IP 54, on request IP 65
Setpoint setting and terminal connections accessible only after removal of the terminal box lid.



Ex
IP 65

Ex-Housing (EEx-d version)

All pressure and differential pressure switches can be equipped with these switch housings and are thus approved for EX \geq 1. Degree of protection IP 65
Ex degree of protection EEx de IIC T6.

Pressure limiters with switching status lock (restart lockout)



In limiter functions it is frequently necessary to retain and lock the shutdown status and to release the lock and switch on the system again only after the causes that led to the safety shutdown have been eliminated. There are two possibilities for this:

1. Mechanical lock inside the pressure switch

A "bistable" microswitch is built into the limiter instead of the microswitch with automatic reset.

When the value set on the scale is reached, the microswitch switches over and remains in this position. The lock must be released by pressing the unlocking button (marked by a red dot on the scale side of the switching device). According to version, the lock can be effective with rising or falling value. Unlocking can take place only if the pressure has dropped by a certain amount or in the case of locking it has risen back to the lower switching point.

When the pressure limiter is selected, a distinction must be made between maximum pressure and minimum pressure monitoring.

Ex-versions cannot be delivered with internal locking.

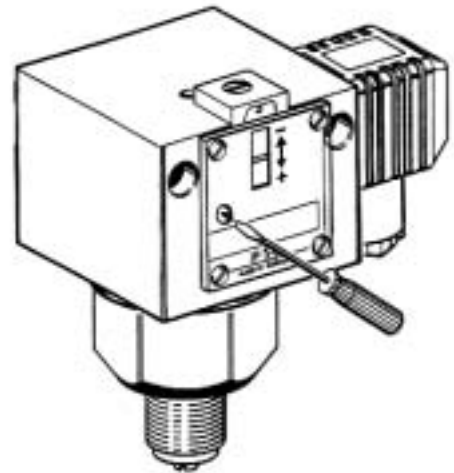

1.1 Maximum pressure limitation

Switching over and locking with rising pressure.

Additional function: 205, ZF 305

Connection to terminal 1 and 3.

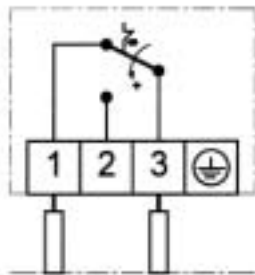

1.2 Minimum pressure limitation

Switching over and locking with falling pressure.

Additional function: 206, 306

Connection to terminal 2 and 3.

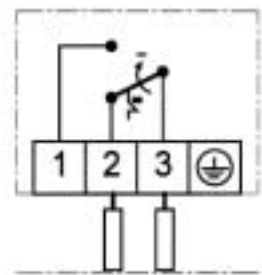

2. External electrical interlock in the switchgear cabinet

A pressure monitor (microswitch with automatic reset) can also be used as limiter if an electrical interlock is connected in series. In pressure limitation in steam and hot water boilers, the external interlock is permissible only if it is ensured that the pressure monitor is of "special construction".

2.1 Maximum pressure limitation with external interlock

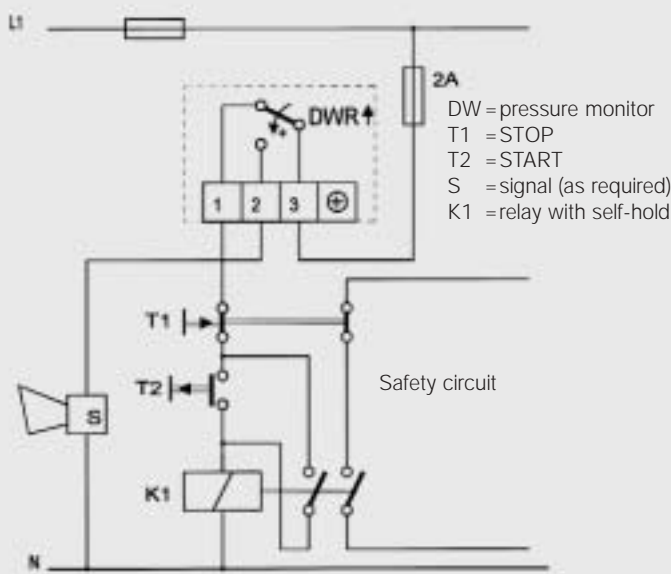

2.2 Minimum pressure limitation with external interlock

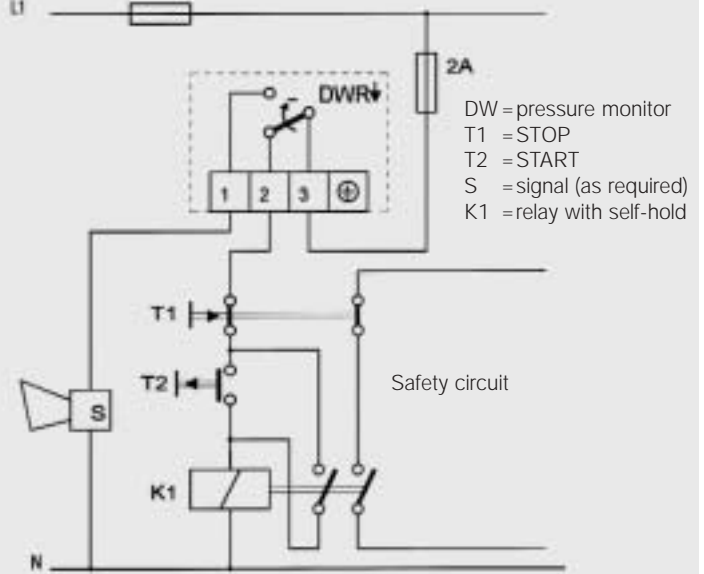

When the interlock circuit shown above is used, the requirements in accordance with DIN 57 116/VDE 0116 are fulfilled if the electrical equipment such as contactors or relays of the external interlock circuit correspond to VDE 0660 or VDE 0435 respectively.

Technical Data

Pressure connection

External thread G 1/2 A (pressure gauge connection) acc. to DIN 16 288 and internal thread G 1/4 to ISO 228 part 1.

Switching device

Rugged housing (200) of seawater resistant aluminium die casting GD Al Si 12.

Protection

IP54, with vertical mounting position.
IP65, with EEx-d version

Pressure sensing element

VNM111 and VNM301
Metal bellows: 1.4571
Sensor casing: 1.4104
VCM095, 101 and 301:
Metal bellows: Cu Zn
Sensor casing: CuZn
VCM4156
Diaphragm: NBR
Sensor casing: 1.4301

Fitting position

Vertically upwards and horizontal.
VCM4156 vertically upwards.

Max. ambient temperature at the switch unit

-25...+70 °C
EEx-d versions: -15...60 °C

Max. temperature of the medium

The maximum temperature of the medium at the pressure sensing element must not exceed the allowable temperature at the switching device.

Temperatures up to 85 °C are allowable for short periods. Higher temperatures of the medium are possible, provided that the upper limit at the switching device is safeguarded by suitable measures (e.g. water tube trap).

Fitting

Directly in the pressure line (pressure gauge connection) or on a flat surface with 2 – off 4 mm screws.

Switching pressure

Adjustable externally by means of screw-driver.

Switching differential

Not adjustable on VCM and Ex-VCM.
Adjustable on VCMV.
For values see Summary of types.

Methods of sealing

As required (may also be carried out after mounting).

Adjustment

Scale value corresponds to the lower switching point, the upper switching point is higher by the switching differential.

Contact agreement

Single-pole change-over switch.

Switching capacity

	250 V ~		250 V - (ohm)	250 V - (ind)
	(ohm)	(ind)		
Normal	8 A	5 A	0.3 A	8 A

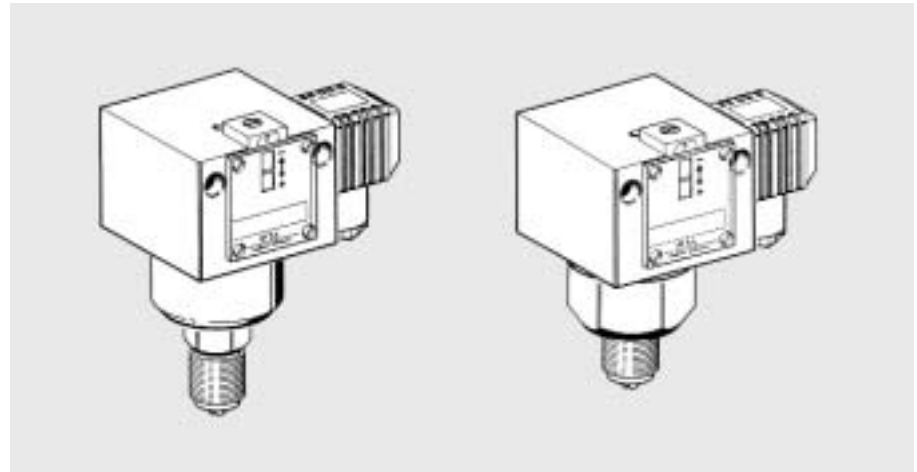

The FEMA Negative Pressure Switches detect the pressure difference relative to the atmospheric pressure. All data on switching pressure ranges and therefore also the scale divisions on the switch units are to be understood at the difference in pressure between the atmospheric pressure at any one time and the set switching pressure.

The "zero" reference point on the scale of the unit corresponds to the atmospheric pressure at the time.

Summary of types

Model	Range of adjustment	Switching difference (Mean value)	Max. allowable pressure	Dimens. drawing
Switching difference not adjustable				
SCH-VCM 4156	-15 to +6 mbar	2 mbar	1 bar	1 + 11
SCH-VCM 301	-250 to +100 mbar	25 mbar	1.5 bar	1 + 13
SCH-VNM 301	-250 to +100 mbar	45 mbar	3 bar	1 + 16
SCH-VCM 101	-1* to +0.1 bar	45 mbar	3 bar	1 + 14
SCH-VCM 095	-0.9 to +0.5 bar	50 mbar	3 bar	1 + 14
SCH-VNM 111	-1* to +0.1 bar	50 mbar	6 bar	1 + 16
Switching difference adjustable				
SCH-VCMV 301	-250 to +100 mbar	30 - 200 bar	1.5 bar	1 + 13
SCH-VNMV 301	-250 to +100 mbar	70 - 450 bar	3 bar	1 + 16
SCH-VCMV 101	-1* to +0.1 bar	80 - 350 bar	3 bar	1 + 14
SCH-VCMV 095	-0.9 to +0.5 bar	90 - 400 bar	3 bar	1 + 14
SCH-VNMV 111	-1* to +0.1 bar	90 - 650 bar	6 bar	1 + 16

*In the case of very high vacuum, close to the negative pressure of -1 bar which is only theoretically possible, the switch can be adjusted only with reservations on account of the special conditions of vacuum technology. The pressure switch itself will however not be damaged at maximum negative pressure.

Above pressure switches can also be supplied with the optional functions see ZF data sheet. For small pressure ranges see HCD data sheet.

1 Normalausführung Steckeranschluss

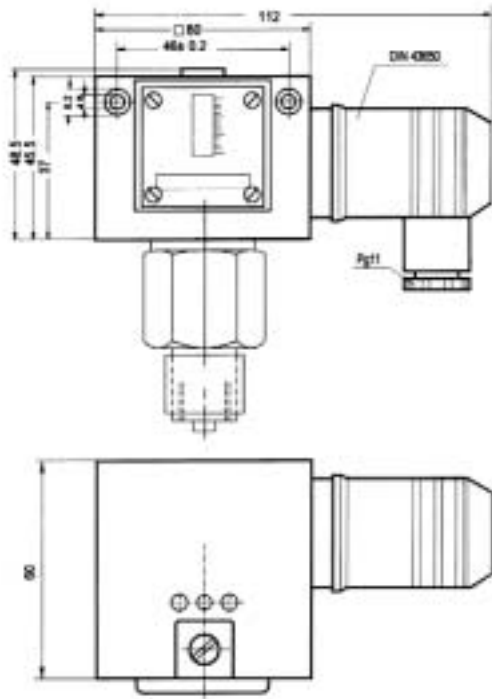

2 Klemmanschluss

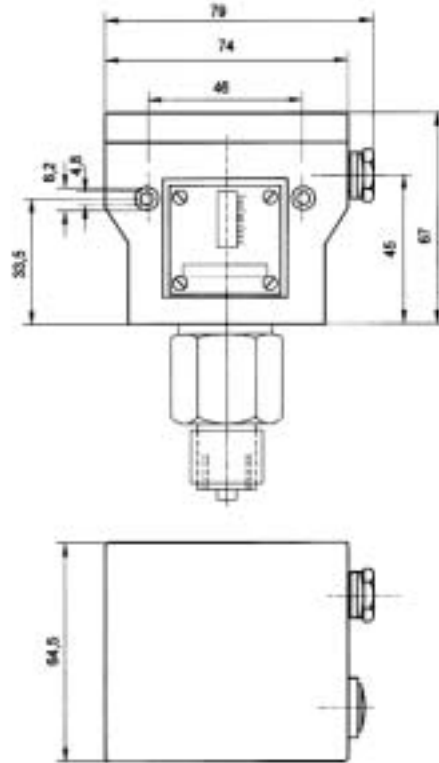

3 -Ausführung

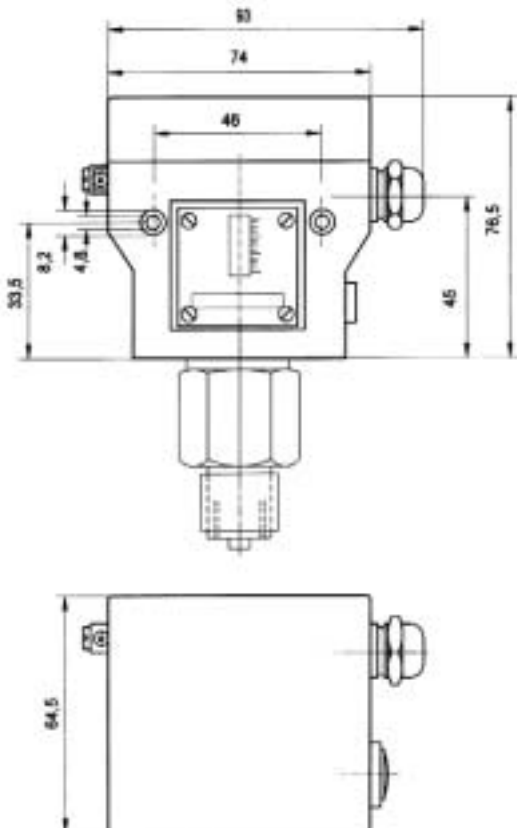

11

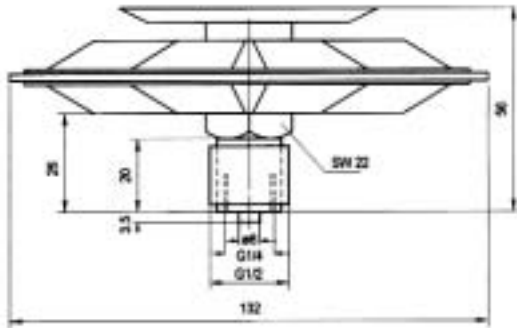

12

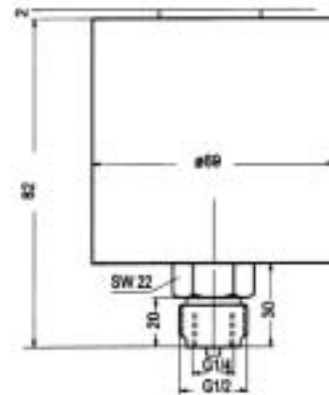

13

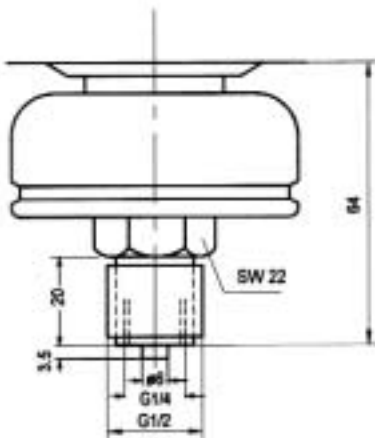

14

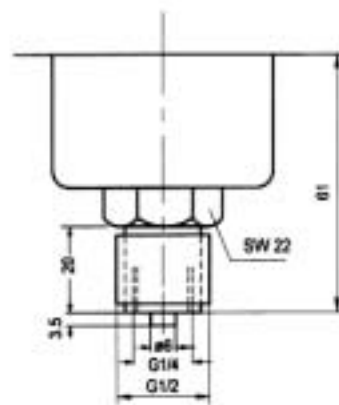

15

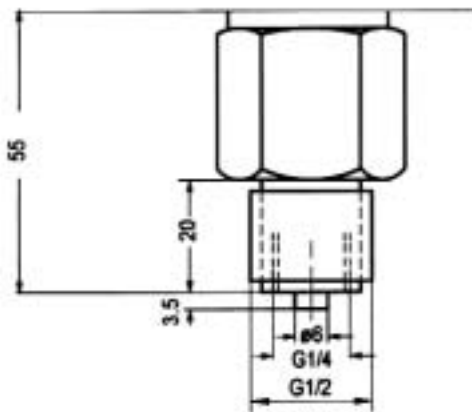

16

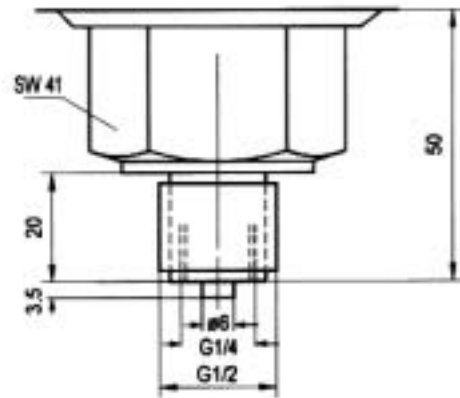

17

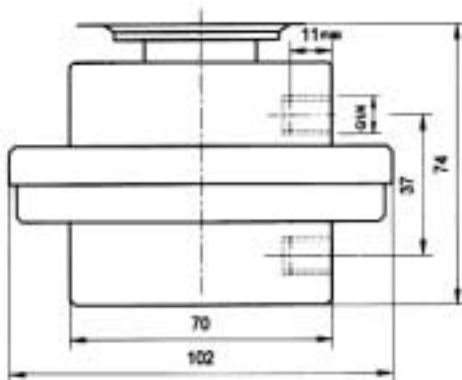

18

