

Paddle Flow Switch for Liquids



- Switching ranges:
2.5 - 4.8 to 383 - 533 l/min water
- p_{max}: 100 bar, t_{max}: 110 °C
- Connection:
G 1/4 to G 1 1/2,
1/4 NPT to 1 1/2 NPT
- Material: brass or stainless steel
- Replaceable stainless steel paddle



KOBOLD offices exist in the following countries:

**ARGENTINA, AUSTRIA, BELGIUM, BRAZIL, CANADA,
CHINA, COLOMBIA, FRANCE, GREAT BRITAIN, NETHERLANDS,
POLAND, SWITZERLAND, USA, VENEZUELA**

KOBOLD Messring GmbH
Nordring 22-24
D-65719 Hofheim/Ts.
☎ (06192) 299-0
Fax (06192) 23398
E-mail: info.de@kobold.com
Internet: www.kobold.com

Model:
PSR/PSE

Description

The KOBOLD flow switches types PSE and PSR are simple, reasonably-priced and reliable monitors of fluid motions.

Depending on the flow velocity/flow throughput, the baffle plate is deflected and it moves over the balance arm the permanent magnet into the operating range of the reed contact mounted outside the process fluid.

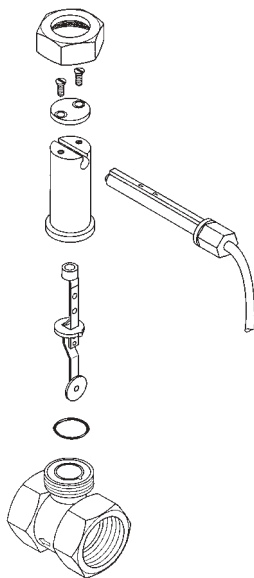

The leaf spring, which also serves as a support for the balance arm, forces the baffle plate back to its rest position when there is no flow. KOBOLD baffle plate flow monitors are supplied completely assembled with pipe length up to nominal size 40. For bigger nominal pipe sizes the devices are supplied without pipe length for direct fitting and are screwed into standard T pieces or reducing pipes. PTFE tape is used for sealing.

PSR and PSE versions

PSR made of brass or stainless steel with fitting and female thread for nominal sizes G 1/4 to G 1 1/2.

PSE made of brass or stainless steel with external thread for larger nominal sizes NW 50 to NW 200.

Model: PSE



Model: PSR



Technical Details

Max. medium temperature: 110 °C
 Max. pressure: 25 bar (PSR-1132..., PSR-1140...) 100 bar (all others)
 Protection type: IP 65
 Mounting position: any

Electrical details

Bistable reed contact

N/O contact / N/C contact
 Max. current: 2 A
 Max. voltage: 230 V_{AC/DC}
 Max. rating: 40 W, 40 VA

Changeover contact

Max. current: 0.5 A
 Max. voltage: 150 V_{AC/DC}
 Max. rating: 20 W, 20 VA
 Cable: PVC (standard 1.5 m)
 Ex-range: ATEX zone 1 as "simple operator"

Materials

	PSR/PSE-11...	PSR/PSE-12...
Case	Brass 58	Stainless steel 1.4301
Baffle plate	Stainless steel 1.4301	Stainless steel 1.4301
Leaf spring	Stainless steel 1.4310	Stainless steel 1.4310
Balance arm	Stainless steel 1.4310	Stainless steel 1.4310
Sleeve	Brass 58	Stainless steel 1.4301
Magnet	Oxide ceramics	Oxide ceramics
Seal	NBR	FPM
Contact tube	Polyamide, glass-fibre-reinforced	

Applications

- Cooling and lubricant circuits
- Dry running protection for pumps
- Prevention of low water levels
- Monitoring of pipe fracture

Special advantages

- Pressure-resistant, forged case for type PSR-xx08 to PSR-xx25
- Baffle plate system made of spring stainless steel. This precludes bending of paddle even with flow rates well outside the switching range.
- Baffle plate exchangeable
- Contact fixing with locking washer. Thus secure contact fixing even with vibrations.



Order details (Example: PSR-1108 3 R08 R1)



Standard switch. ranges*		Nominal size	Qmax. l/min. water	Model		Connection	Type of contact / PVC cable
Rising flow rate l/min. water	Falling flow rate l/min. water			Material brass	Material stainless steel		
2.3-4.7	1.6-4.6	DN 8	30	PSR-1108 3...	PSR-1208 3...	R08=G 1/4 N08=1/4 NPT	Standard R1=N/C contact 1.5 m Special U1=changeover c. 1.5 m R2=N/C contact 2.0 m R4=N/C contact 3.0 m R6=N/C contact 4.0 m R8=N/C contact 5.0 m
2.3-5.5	2.8-6.0	DN 10	40	PSR-1110 3...	PSR-1210 3...	R10=G 3/8 N10=3/8 NPT	
2.5-6.4	1.9-6.3	DN 15	45	PSR-1115 3...	PSR-1215 3...	R15=G 1/2 N15=1/2 NPT	
7.7-13.4	5.9-13.0	DN 20	80	PSR-1120 6...	PSR-1220 6...	R20=G 3/4 N20=3/4 NPT	
7.4-18.2	7.3-17.2	DN 25	130	PSR-1125 8...	PSR-1225 8...	R25=G 1 N25=1 NPT	
19.7-36.8	20.0-32.4	DN 32	160	PSR-1132 B...	PSR-1232 B...	R32=G 1 1/4 N32=1 1/4 NPT	
23.1-57.9	23.5-53.1	DN 40	300	PSR-1140 B...	PSR-1240 B...	R40=G 1 1/2 N40=1 1/2 NPT	



Special switch. ranges*		Nominal size	Qmax. l/min. water	Model		Connection	Type of contact / PVC cable
Rising flow rate l/min. water	Falling flow rate l/min. water			Material brass	Material stainless steel		
4.7-6.5	3.4-6.1	DN 8	30	PSR-1108 2...	PSR-1208 2...	R08=G 1/4	Standard R1=N/C contact 1.5 m Special U1=changeover c. 1.5 m R2=N/C contact 2.0 m R4=N/C contact 3.0 m R6=N/C contact 4.0 m R8=N/C contact 5.0 m
5.7-7.7	4.5-7.6	DN 8	30	PSR-1108 1...	PSR-1208 1...	N08=1/4 NPT	
5.5-7.1	4.4-6.9	DN 10	40	PSR-1110 2...	PSR-1210 2...	R10=G 3/8	
6.6-8.7	5.6-8.5	DN 10	40	PSR-1110 1...	PSR-1210 1...	N10=3/8 NPT	
8.3-10.7	7.0-10.3	DN 15	45	PSR-1115 2...	PSR-1215 2...	R15=G 1/2	
9.2-12.4	8.0-11.8	DN 15	45	PSR-1115 1...	PSR-1215 1...	N15=1/2 NPT	
17.8-24.9	14.9-23.3	DN 20	80	PSR-1120 5...	PSR-1220 5...	R20=G 3/4	
20.4-30.0	16.3-28.3	DN 20	80	PSR-1120 4...	PSR-1220 4...	N20=3/4 NPT	
34.6-48.3	30.6-46.7	DN 20	80	PSR-1120 1...	PSR-1220 1...		
17.7-26.8	12.8-24.7	DN 25	130	PSR-1125 7...	PSR-1225 7...		
26.0-36.3	21.4-34.1	DN 25	130	PSR-1125 5...	PSR-1225 5...	R25=G 1	
29.8-42.8	24.7-40.9	DN 25	130	PSR-1125 4...	PSR-1225 4...	N25=1 NPT	
47.6-67.2	43.9-64.9	DN 25	130	PSR-1125 1...	PSR-1225 1...		



Standard switch. ranges*		for pipes with diameter (mm)	Qmax. m³/min. water	Model		Connection	Type of contact / PVC cable
Rising flow rate l/min. water	Falling flow rate l/min. water			Material brass	Material stainless steel		
68-90	61-83	50	30	PSE-1149 8...	PSR-1249 8...	R15=G 1/2 N15=1/2 NPT	Standard R1=N/C contact 1.5 m Special U1=changeover c. 1.5 m R2=N/C contact 2.0 m R4=N/C contact 3.0 m R6=N/C contact 4.0 m R8=N/C contact 5.0 m
183-250	170-233	80	100				
320-400	300-383	100	150				
700-917	667-900	150	200				
50-62	43-58	50	30	PSE-1152 0...	PSE-1252 0..	R15=G 1/2 N15=1/2 NPT	Special U1=changeover c. 1.5 m R2=N/C contact 2.0 m R4=N/C contact 3.0 m R6=N/C contact 4.0 m R8=N/C contact 5.0 m
155-183	143-167	80	100				
217-267	200-250	100	150				
558-600	517-592	150	200				
92-113	70-103	100	150	PSE-1114 9...	PSE-1214 9...	R15=G 1/2 N15=1/2 NPT	Special U1=changeover c. 1.5 m R2=N/C contact 2.0 m R4=N/C contact 3.0 m R6=N/C contact 4.0 m R8=N/C contact 5.0 m
200-283	167-233	150	200				
383-533	333-467	200	200				

*Listed values are valid only for horizontal installation



Dimensions

Model: PSE

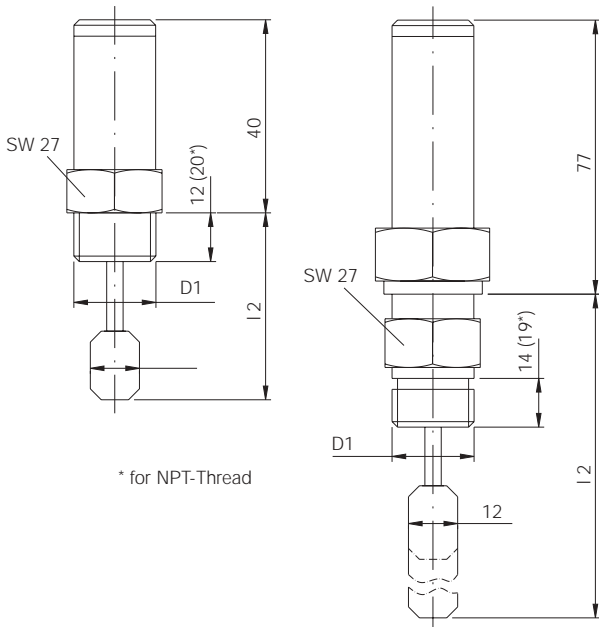

* for NPT-Thread

Model	D1	l ₂ (mm)
PSE-..49	R 1/2	49
PSE-..52	R 1/2	52
PSE-..14	R 1/2	114

Model: PSR

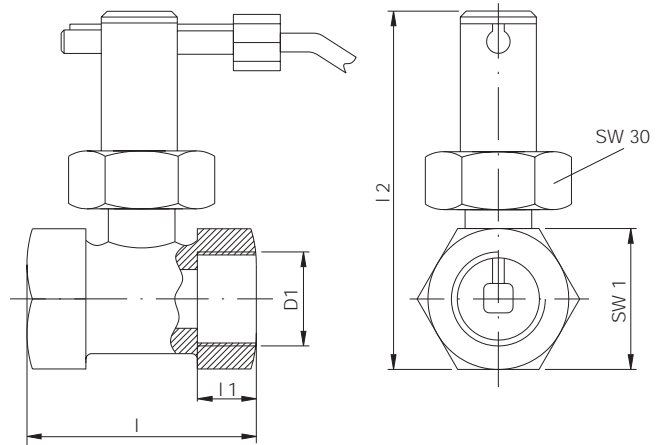

Model	D1	l (mm)	l ₁ (mm)	l ₂ (mm)	SW 1
PSR-..08	G 1/4	50	10	80	27
PSR-..10	G 3/8	50	10	80	27
PSR-..15	G 1/2	50	10	80	27
PSR-..20	G 3/4	52	15	81.5	32
PSR-..25	G 1	56	15	84	39
PSR-..32	G 1 1/4	50	15	112	46
PSR-..40	G 1 1/2	50	15	119	55

Switching point setting

To set the switching point loosen the locking washer at the top of the casing and move the contact unit. A blue, white/red arrow located on the contact unit serves as an adjustment aid. The front edge of the locking washer serves as adjustment mark.

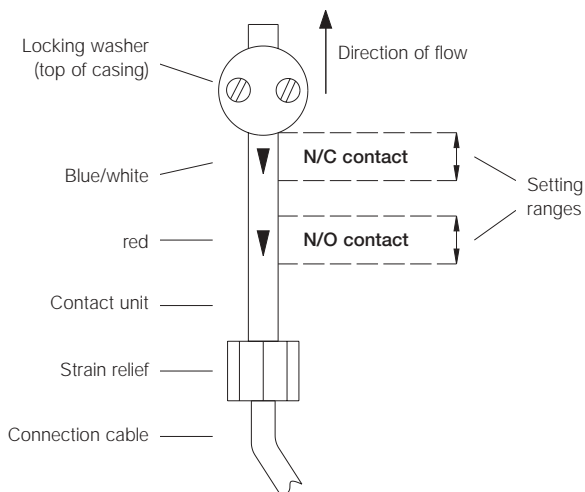

N/O contact

The switching volume can be adjusted at the red arrow. The minimum switching values specified in the table are set by moving the contact unit in the flow direction. The maximum switching values given in the table are set by moving the contact unit against the direction of flow.

N/C contact

The switching volume can be adjusted at the blue (white) arrow. The minimum switching values specified in the table are set by moving the contact unit in the flow direction. The maximum switching values given in the table are set by moving the contact unit against the direction of flow. Firmly tighten locking washer again when settings have been made.