



## Low Volume Variable Area Flow Meters/Monitors for Liquids



measuring  
•  
monitoring  
•  
analysing



- Switching range:  
0.05-0.1 to 13-24 L/min  
Water
- Repeatability:  
 $\leq \pm 2.5\%$  f. s.
- $p_{\max}$  250 bar,  $t_{\max}$  100°C
- Connection: G  $\frac{1}{2}$
- Material:  
Brass, stainless steel, PVC



KOBOLD offices exist in the following countries:

ARGENTINA, AUSTRIA, BELGIUM, BRAZIL, CANADA, CHINA,  
FRANCE, GERMANY, GREAT BRITAIN, ITALY, MEXICO, NETHER-  
LANDS, PERU, POLAND, SWITZERLAND, USA, VENEZUELA

KOBOLD Messring GmbH  
Nordring 22-24  
D-65719 Hofheim/Ts.  
☎ +49(0)6192 299-0  
Fax +49(0)6192 23398  
E-Mail: info.de@kobold.com  
Internet: www.kobold.com

**Model:**  
SWK



**Description**

KOBOLD flow meters and monitors of model SWK operate on the known suspended float principle, however without using the generally known conical measuring tube. An orifice float moves in the direction of flow against the force of a spring in a cylindrical guide tube. The float contains a permanent magnet which operates a floating sealed contact (reed contact) mounted on the outside. The instruments are small and can be mounted in any orientation. Model SWK flow switches are ideally suited for monitoring low flows.

**Dimensions**

SWK-1...

SWK-2...

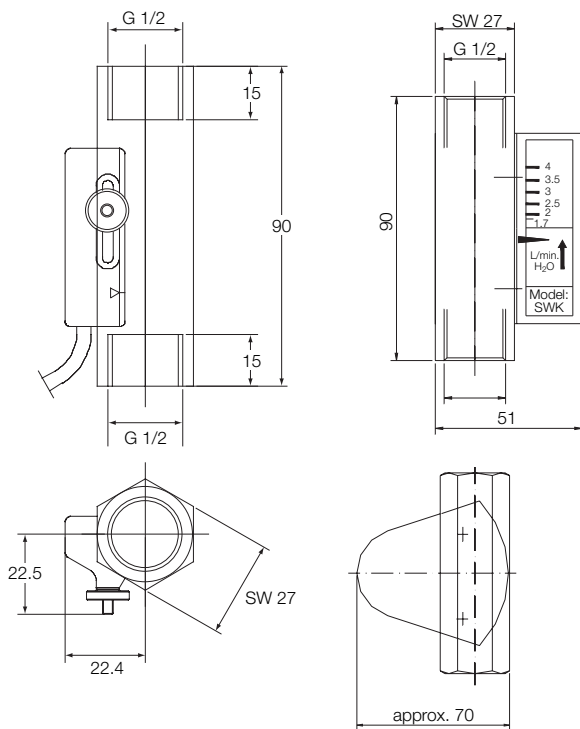

**Technical Details**

- Housing: SWK-x1...: brass nickel plated, Ms 58  
SWK-x2...: stainless steel, 1.4301  
SWK-13...: PVC
- Connections: G 1/2 female
- Float: SWK-x1...: brass, Ms 58  
SWK-x2...: stainless steel, 1.4301  
SWK-13...: PVC
- Magnets: ceramic
- Compression spring: stainless steel 1.4310
- Gaskets: none
- Butt rings: SWK-x1...: brass, Ms 58  
SWK-x2...: stainless steel, 1.4301  
SWK-13...: PVC
- Max. temperature: SWK-x1..., SWK-x2: 100 °C  
SWK-13...: 60 °C
- Max. pressure: SWK-x1..., SWK-x2: 250 bar  
SWK-13...: 6 bar
- Loss of pressure: 200 mbar at ME
- Installation position: any position
- Switch contact: bistable reed contact  
N/O contact with increasing flow rate
- Breaking capacity: max. 230 V<sub>AC/DC</sub>, max. 3 A  
max. 60 W/VA
- Electr. connection: 1 m PVC cable
- Switching hysteresis: 3 mm on scale (mean value)
- Repeatability: ≤ 2.5 % (contact)  
± 4 % f. s. (indicator)
- Protection: IP 65
- Ex range: ATEX Zone 1 as "simple operator"

**Applications**

- Lubricant circuits
- Paper-making machines
- Machine tools
- Glass-melting tanks
- Cooling circuits
- Welding machines
- Induction furnaces
- Pumps

**Order Details** (Example: SWK-1101)

Switching range L/min water	Connection female	Flow monitors			Flow meters and monitors	
		Material brass	Material stainless steel	Material PVC	Material brass	Material stainless steel
0.05 - 0.1	G 1/2	SWK 1101	SWK 1201	-	SWK 2101	SWK 2201
0.1 - 0.2	G 1/2	SWK 1102	SWK 1202	-	SWK 2102	SWK 2202
0.2 - 0.8	G 1/2	SWK 1108	SWK 1208	SWK 1308	SWK 2108	SWK 2208
0.5 - 1.8	G 1/2	SWK 1118	SWK 1218	SWK 1318	SWK 2118	SWK 2218
1.7 - 4.0	G 1/2	SWK 1140	SWK 1240	SWK 1340	SWK 2140	SWK 2240
4.0 - 9.0	G 1/2	SWK 1190	SWK 1290	SWK 1390	SWK 2190	SWK 2290
8 - 16	G 1/2	SWK 1116	SWK 1216	SWK 1316	SWK 2116	SWK 2216
13 - 24	G 1/2	SWK 1124	SWK 1224	SWK 1324	SWK 2124	SWK 2224