



- p_{max} : 10 bar
 t_{max} : 100 °C
 (150 °C for CIP process)
- Process connections:
 G 1/2, M12x1.5
 installation meets hygiene
 standards through EHEDG-certified
 installation system LZE
- Materials approved for handling
 of foodstuffs
- Independent of the conductivity
 of the medium
- Measurement is possible despite
 foam and deposits
- Optimum flow geometry



Weld-in sleeve LZE



KOBOLD companies worldwide:

ARGENTINA, AUSTRIA, BELGIUM, CANADA, CHILE, CHINA, CZECH
 REPUBLIK, FRANCE, GERMANY, GREAT BRITAIN, INDONESIA, ITALY,
 MALAYSIA, MEXICO, NETHERLANDS, PERU, POLAND, SWITZERLAND,
 SINGAPORE, SLOVAKIA, THAILAND, USA, VENEZUELA, VIETNAM

KOBOLD Messring GmbH
 Nordring 22-24
 D-65719 Hofheim/Ts.
 ☎ +49(0)6192 299-0
 Fax +49(0)6192 23398
 E-Mail: info.de@kobold.com
 Internet: www.kobold.com

Model:
 LNM



Description:

The KOBOLD LNM microwave level switch is used for detecting levels of fill. The microwave field penetrates several millimetres into the medium. Foam, condensate or remains of the transported medium that have stuck on to the tank are not detected.

By using this principle of measurement it is also possible to detect non-conductive media. The level switch is particularly suitable for use with foaming media because the foam itself is not detected. The output of the level switch only switches when the coupling section is completely covered by the medium. This means it is possible to install it into tanks regardless of position.

In combination with the KOBOLD LZE or LZE-R weld-in sleeves, the probe provides a measuring point that has no dead space and meets hygiene standards and (EHEDG approval certificate). This level switch is therefore very well suited for CIP/SIP cleaning. Adapter sleeves are also available for different process connections so that the device can also be used in existing systems.

Because the electronics are already integrated no other evaluating instrument is necessary. The output signal (24 V_{DC}) can therefore be transmitted direct to an SPS for further processing.

Fields of use:

- Level monitoring, for conductive and non-conductive media
- Safe level monitoring, even with foam and deposits
- Phase separation oil/water
- With option ϵ_R 2-20 it is also possible to detect oil and alcohol

Technical data:

Measuring principle: Microwave technology
 Process temperature: 0...100 °C
 150 °C max. 30 min for CIP process
 Ambient temperature: 0...70 °C

Order data (Example order: **LNM-12 G4 A 3PK**)

Design	Material	Process connection	Sensitivity	Model	Electr. connection
Foodstuffs*	St. steel/PEEK	G 1/2	ϵ_R : >20	LNM-12 G4 A...	...3PK = M16x1.5 threaded cable connection ...3PS = M12x1 plug
Industry	St. steel/PEEK	G 1/2	ϵ_R : >20	LNM-22 G4 A...	
Foodstuffs*	St. steel/PEEK	M12	ϵ_R : >20	LNM-12 M3 A...	
Foodstuffs*	St. steel/PEEK	M12	ϵ_R : 2-20	LNM-12 M3 B...	

*Installation only possible with EHEDG sleeve

Technical data (continued):

Working pressure: max. 10 bar
 Material
 • Head, thread supports: stainless steel 1.4404
 • Coupler section: PEEK
 Process connection: G 1/2, M12 x 1,5 hygienic
 Weld-in sleeves LZE, LZE-R (see page 53-60)
 Connection: threaded cable connection
 M16 x 1.5
 Terminal: 3-pole, (optional plug M12 x 1)
 Function: Full/empty report (determined via the polarity of the supply voltage)
 Output: Open Collector, PNP, 50 mA
 Switch delay: 0.2 s (0.3 - 1.0 s on request)
 Power supply: 18...36 V_{DC}, <50 mA without load
 Protection: IP 67
 Weight: approx. 0.5 kg
 Dielectric constant of the medium: ϵ_R >20; Option: ϵ_R 2-20

Dimensions:

Process connection M12x1.5

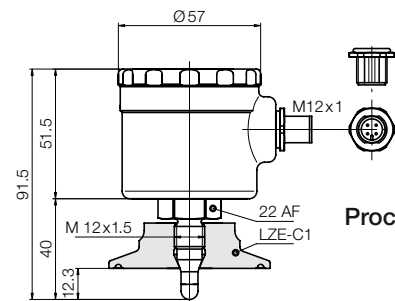

Process connection G 1/2

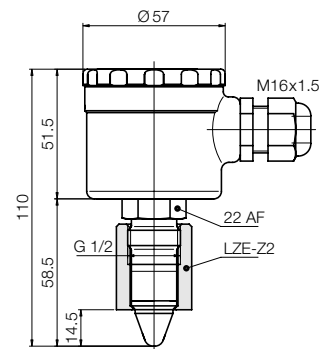

EHEDG certification of the connection system in combination with weld-in sleeve LZE (see Page 53-60)