

## COMPACT-LINE



- Measuring range  
0 to 200 mS/cm
- Display of conductivity  
(in  $\mu\text{S}/\text{cm}$  or mS/cm)  
and temperature
- Easy to configure
- Cell constants available:  
0.01 / 0.1 / 1.0 / 3.0 /  
10.0 1/cm
- Compact design
- Calibration procedure for  
temperature coefficient of the  
solution and the relative cell  
constant
- Analogue actual-value  
output scaleable  
(electrically isolated)
- External setpoint value  
changeover possible
- Two relays programmable  
as a controller
- Two binary inputs
- One binary output  
(alarm contact or  
temperature limit contact)



KOBOLD offices exist in the following countries:

ARGENTINA, AUSTRIA, BELGIUM, BRAZIL, CANADA, CHINA,  
 FRANCE, GERMANY, GREAT BRITAIN, ITALY, NETHERLANDS,  
 POLAND, PERU, SWITZERLAND, USA, VENEZUELA

KOBOLD Messring GmbH  
 Nordring 22-24  
 D-65719 Hofheim/Ts.  
 ☎ (06192) 299-0  
 Fax (06192) 23398  
 E-mail: info.de@kobold.com  
 Internet: www.kobold.com

**Model:**  
 ACM-Z



**Description**

The compact microprocessor transmitter/controller measures and controls the conductivity in aqueous solutions. It is available as a panel-mounted device according to DIN 43 700 or in a field housing.

Its simple operation and user-friendly programming allow universal service in almost all areas of industrial metrology.

The transmitter is fitted with two analogue and two binary inputs. The first analogue input is suited for connecting conductive conductivity measuring cells with cell constants 0.01; 0.1; 1.0; 3.0 and 10.0 1/cm, depending on the desired measuring range (see table "Cell constant and measuring range"). A Pt 100 resistance thermometer may be connected to the second analogue input.

The device has two 4-position, 7-segment displays for indicating conductivity (red) and temperature (green).

The display show comments during programming.

The two controller relays can be configured as limit value and/or pulse lengths or pulse frequency controllers with P, PI, PD or PID structure. A maximum of two relay make contacts, one binary output and one analogue actual-value output is available.

To simplify programming and operation, controller parameters and configuration data have been assigned to different levels.

- User level
- Parameter level
- Configuration level

The levels are secured with pass words against unauthorized access. Membrane keys ensure simple and user-friendly operation.

Both LEDs show parameter symbols and values.

**A complete measuring device comprises:**

- the conductivity transmitter model ACM-Z
  - a conductivity measuring cell model ACS-Z with integrated temperature sensor
  - a suitable conductivity measuring cable model ACK-Z
- as well as one of the following:*
- transmitter wall (AZM-Z1) or pipe mounting (AZM-Z2) accessory.
  - flow or immersion assembly for installation and protection of the electrodes (see Accessories)

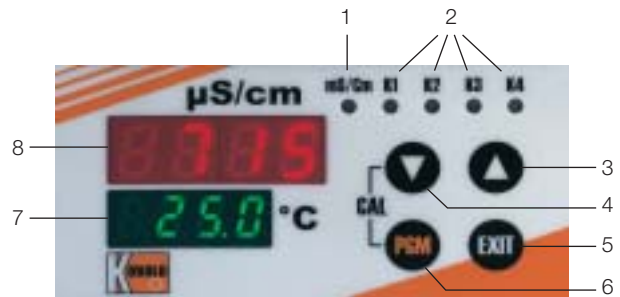

- 1 LED display: in mS/cm
- 2 Control state indicators (yellow) for outputs 1 to 4
- 3 Increment key for changing parameters and manually operating relay K2
- 4 Decrement key for changing parameters and manually operating relay K1
- 5 EXIT key to leave the levels
- 6 PGM-key for selecting the parameters and confirming entries
- 7 4-segment temperature display (LED, green, 8 mm high)
- 8 4-segment actual-value indication (LED, red, 13 mm high)
- 4+6 "CAL": start calibration of electrodes (single or two-point calibration)
- 3+5 Starting hand operation or Hold.

**Cell constant and measuring range**

Cell constant (KB)	Measuring range <sup>B)</sup>	Display for configured-measuring quantity		Range (rAnG)
		µS	mS	
0.01	0...0.500 µS/cm	0.500	A)	1
0.01	0...2.000 µS/cm	2.000	A)	2
0.01	0...10.00 µS/cm	10.00	A)	3
0.1	0...5.000 µS/cm	5.000	A)	4
0.1	0...20.00 µS/cm	20.00	A)	5
0.1	0...100.0 µS/cm	100.0	A)	6
0.1	0...1.000 mS/cm	1000	1.000	7
0.1	0...5.000 mS/cm	5000	5.000	8
1.0	0...50.00 µS/cm	50.00	A)	9
1.0	0...100.0 µS/cm	100.0	A)	10
1.0	0...1.000 mS/cm	1000	1.000	11
1.0	0...5.000 mS/cm	5000	5.000	12
1.0	0...20.00 mS/cm	A)	20.00	13
1.0	0...100.0 mS/cm	A)	100.0	14
3.0	0...1.000 mS/cm	1000	1.000	15
3.0	0...5.000 mS/cm	5000	5.000	16
3.0	0...30.00 mS/cm	A)	30.00	17
10.0	0...30.00 mS/cm	A)	30.00	18
10.0	0...200.0 mS/cm	A)	200.0	19

A) These settings are not allowed and cause incorrect indication  
 B) The pre-selection of the measuring range and the cell constant is carried out with the code number "Range" in transmitter ACM-Z



**Application examples for conductivity measurements:**

**Low conductivity (to 500  $\mu\text{S/cm}$ )**

- CIP cleaning (rinsing cycle in the food industry)
- Monitoring the boiler feed water
- Monitoring and assessing ion exchanger
- Monitoring the reverse osmosis
- Monitoring the cooling waters
- Inspection of sea water desalination

**Average conductivity (to 10 mS/cm)**

- Inspection of drinking water treatment
- Desalting of cooling water
- Waste water inspection in clarification plants

**High conductivity (to 500 mS/cm))**

- Quality control for drinks (for example milk, beer)
- Monitoring bottle cleaning plants
- Control of concentration of acids and lyes (for example CIP cleaning, electroplating plants)
- Detection of phase boundaries (product/water separation)

**Technical Datas**

**General**

● Measuring and control range:	0 - 200 mS/cm (depending on cell constant)
● Measuring error:	$\leq 0.25\%$ of measuring range
● Influence of ambient temperature:	$\leq 0.15\%$ / 10 K
● Temperature display:	-50...+250 °C
● Measuring error:	$\leq 0.25\%$ of measuring range
● Influence of ambient temperature:	$\leq 0.1\%$ / 10 K
● Data back-up:	EEPROM
● Power supply:	110 - 240 V <sub>AC</sub> , +10%/-15%, 48 - 63 Hz or 20 - 53 V <sub>AC/DC</sub> , 48 - 63/0 Hz
● Power consumption:	approximately 8 V A
● Electrical connection	with gold-plated flat connector according to DIN 46 244/A; 4.8 mm x 0.8 mm
● Ambient temperature:	0 - +50 °C (at reference conditions)
● Ambient temperature:	-10 - +55 °C (at limit operating conditions)
● Storage temperature:	-40 - +70 °C
● Humidity:	relative humidity $\leq 95\%$ non-condensing
● Protection according to EN 60 529:	panel housing: front IP 65/rear IP 20 field housing: IP 65
● Electrical security:	according to EN 61 010, clearances in air and creepage distances for -overvoltage category II -pollution degree 2
● Electromagnetic compatibility	according to NAMUR recommendation NE21, EN 50 081 part 1, EN 50 082 part 2
● Housing for panel mounting	housing for panel mounting made of conductive plastic according to DIN 43 700, base material ABS, with plugging controller insert
● Field housing:	aluminium, powder coated with plastic caps
● Installation position:	any
● Weight:	approximately 320 g (panel-mounted device) approximately 1500 g (in field housing)



### Inputs

- Analogue input 1: Conductive conductivity measuring cells with cell constants 0.01; 0.1; 1.0; 3.0; and 10.0 1/cm v  
The cell constant may be adjusted in the range 80 - 120%
- Line balancing of analogue input 1: compensation of influence of longer cables with measuring ranges > 20 mS/cm possible..
- Analogue input 2: resistance thermometer Pt 100 or Pt 1000, in two or three-wire circuitry  
-50 - +250 °C, read-out display in °C
- Line balancing of analogue input 2: compensation of line resistance by actual-value correction possible  
(not required when connecting a resistance thermometer in three-wire circuitry)  
When connecting a resistance thermometer in three-wire circuitry line balancing can also be performed with an external line balancing resistor
- Function of binary inputs 1 and 2: Both binary inputs can be operated with floating contacts (relay) or switches

  - Keyboard interlock
  - Setpoint changeover
  - Measured value freezing
  - »Hold«
  - Alarm stop
  - Measured-value expansion (x10)

### Outputs

- Output 1 and 2 (relay): N/O contact  
(N/O contact, can also be configured as a N/C contact)  
Switching capacity: 3 A, 250 V<sub>AC</sub>  
Service life of contact under resistive load: > 5x10<sup>5</sup> switching operations at load rating
- Output 3 (binary output): 0/5 V R<sub>Load</sub> ≥ 250 Ω (standard)
- Output 4 (actual-value analogue output): configurable: 0(2) - 10 V R<sub>Load</sub> ≥ 500 Ω or  
0(4) - 20 mA R<sub>Load</sub> ≥ 500 Ω, electrically isolated to the inputs: ΔU ≤ 30 V<sub>AC</sub> or ΔU ≤ 50 V<sub>DC</sub>
- Output 5 (analogue output temperature): configurable: 0(2) - 10 V R<sub>Load</sub> ≥ 500 Ω or  
option 0(4) - 20 mA R<sub>Load</sub> ≥ 500 Ω, electrically isolated to the inputs: ΔU ≤ 30 V<sub>AC</sub> or ΔU ≤ 50 V<sub>DC</sub>  
also programmable as continuous action controller
- Measuring errors for output signal: < 0.25 % ± 50 ppm/K



### General controller characteristic values

● A/D-converter	resolution >15 Bit
● Controller types (configurable and mixable): limit controller:	pulse length controller, pulse frequency controller Control algorithm: P, PI, PID or PD configurable
● Sampling interval:	210 ms
● Measuring circuit	monitoring: input 1: out-of-range, input 2: out-of-range, sensor short-circuit, sensor breakage. The outputs go to a defined (configurable) state.



**Dimensions**

**Field housing**

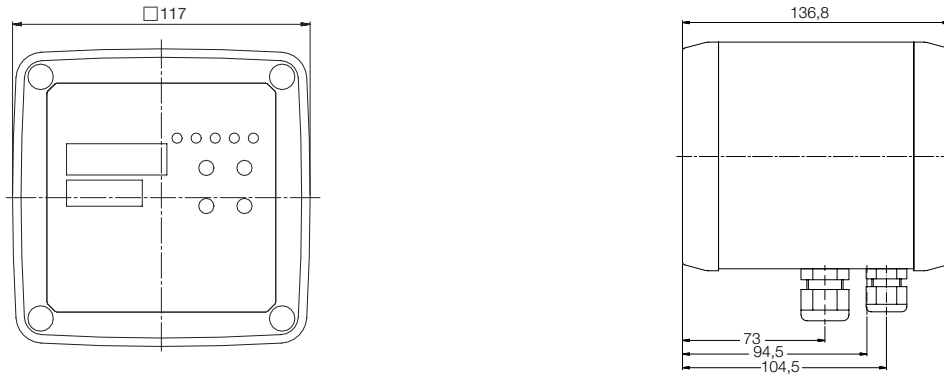

**Panel mounting housing**

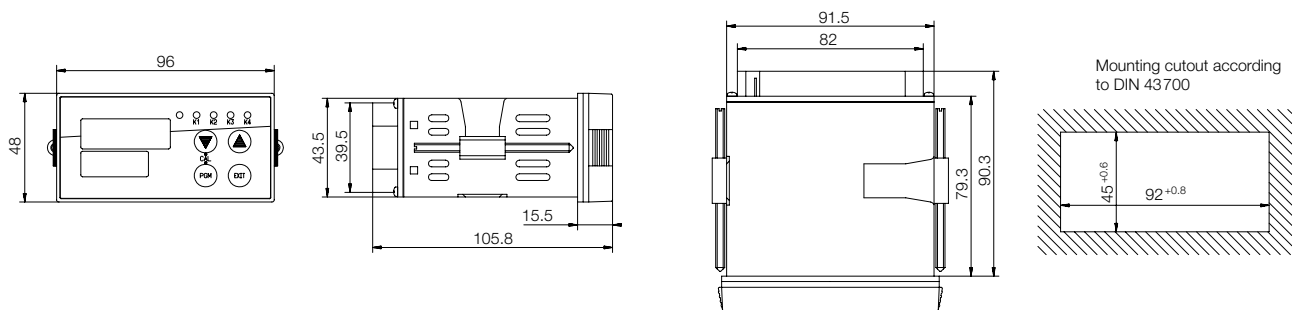

**Type codes ACM-Z**

