



- Immersion assemblies
- Flow assemblies
- Process assembly
- Buffer solutions for pH and ORP
- Calibration solutions for conductivity
- Temperature sensors
- Wall mounting sets for field housing
- Pipe mounting set for field housing



KOBOLD offices exist in the following countries:

ARGENTINA, AUSTRIA, BELGIUM, BRAZIL, CANADA, CHINA, FRANCE, GERMANY, GREAT BRITAIN, ITALY, NETHERLANDS, POLAND, PERU, SWITZERLAND, USA, VENEZUELA

KOBOLD Messring GmbH
 Nordring 22-24
 D-65719 Hofheim/Ts.
 ☎ (06192) 299-0
 Fax (06192) 23398
 E-mail: info.de@kobold.com
 Internet: www.kobold.com

Immersion, Flow and Process Assemblies

Immersion and flow assemblies serve for the mounting and protection of measuring sensors (glass and metal electrodes, conductivity measuring cells, compensating thermometers and so on).

Immersion assemblies not only enable measurements on the surface of the medium being analysed, but also deep in the liquid with a suitable bulb length.

The connection head of the measuring sensor remains "dry". Flow through fittings enable direct measurements in feed pipelines for the medium being analysed or in the bypass for these lines.

The measuring sensor responds instantaneously to changes in the medium thus minimizing dead times in the plant.

The assemblies can be secured to suit the application with fixing elements, such as, retaining brackets, flanges or other clamping fixtures in or at the vessel.

The process assembly allows installation and removal of the sensor online, that is the cycle or main flow must not be interrupted for maintenance work. This assembly is recommended for use in all closed circuits or vessels.

The assemblies must be easily accessible to enable regular maintenance and calibration of the electrodes.



● Immersion assembly for a glass electrode conduit thread 13.5 (model AZA-Z3)



Material:	PP (Polypropylene)
Pipe cross-section:	40 mm
Length of immersion:	500 mm (others on request)
Allowed medium temp.:	95 °C
Equipotential bonding pin:	Stainless Steel 1.4571
Weight:	approximately 0.6 kg
Mounting:	surface mounting with pipe clamps

Wetting shell model AZA-Z3N

For use with installation in open channels for maintaining the electrodes permanently wet.

Cleaning probe model AZA-Z3S

To clean the electrode in the assembly. The cleaning probe is secured at the side of the immersion assembly.

● Immersion assembly for an electrode NPT 3/4" (Model AZA-X1)

For use with pH electrode model APS-X5K and ORP electrode model ARS-X5K



Material:	PVC
Operating temperature:	0...60 °C
Total length:	1630 mm
Depth of immersion:	approximately max. 1400 mm
Mounting:	surface mounting tube clips
Equipot. bonding pin:	not available
Weight:	approximately 1 kg

Cleaning probe model AZA-X1S

To clean the electrode in the assembly. The cleaning probe is secured at the side of the immersion assembly.

● Immersion assembly for three glass electrodes conduit thread 13.5 (model AZA-X2)



Material:	PP (Polypropylene)
Pipe cross-section:	76 mm
Length of immersion:	1000 mm (others on request)
Allowed medium temp.:	80 °C
Equipotential bonding pin:	Stainless Steel 1.4571
Mounting:	flange DN 100, also with captive thumb screws
Required cross section:	DN 100
Weight:	approximately 4 kg

Wetting shell model AZA-X2N

For use in open channels or tanks, for maintaining the electrodes permanently wet.

Cleaning probe model AZA-X2S

To clean the electrode in the assembly. The cleaning probe is secured at the side of the immersion assembly.

Calibration cap model AZA-X2K

For calibrating electrodes (max. volume 70 mL). The calibration cap can be easily mounted on the electrode bracket.

Hanger model AZA-X2H

For flexible installation of the assembly in an open channel or vessel. The hanger is manufactured from stainless steel. A flexible depth of immersion can be reached with a fixing chain.

● Flow assembly for three glass electrodes conduit thread 13.5 with electrode protective cover (model AZA-X4)



Material:	PP (Polypropylene)
Connection:	thread G 1"
Equipotential bonding pin:	Stainless Steel 1.4539
Operating pressure and temperature:	pressureless to 90 °C 6 bar at 20 °C
Weight:	1.2 kg

● **Flow assembly for three glass electrodes conduit thread 13.5 (model AZA-Z5)**



Housing material:	PP (Polypropylene)
Measuring vessel:	Macrolon
Connection:	G 1/2
Equipotential bonding pin:	Stainless Steel 1.4571
Operating pressure and temperature:	pressureless to 90 °C 6 bar at 25 °C
Weight:	0.4 kg

● **Process assembly for one glass electrode conduit thread 13.5 (model AZA-Z6)**



Material:	Stainless Steel 1.4571
Sealing material:	FPM
Connection:	G 3/4
Immersion length:	62 mm (sensor extended)
Max. pressure:	10 bar (20 °C)
Max. temperature:	135 °C
Equipotential bonding pin:	Stainless Steel 1.4571
Weight:	0.8 kg

Calibration and buffer solutions



● **Technical pH buffer solutions model AZP-W**

For calibrating pH electrodes.

Volume: 100 mL, 1000 mL

pH 4 (red) ± 0.02 pH (at 20 °C)

pH 7 (green) ± 0.02 pH (at 20 °C)

pH 9 (blue) ± 0.02 pH (at 20 °C)

● **Potassium chloride solution (3-molar)**

For refilling the internal electrolyte for liquid-filled pH combined electrodes and for storing the electrodes

Volume: 100 mL, 1000 mL;

KCl solution 3 mol/L ± 0.05 mol/L

Type codes AZP-W

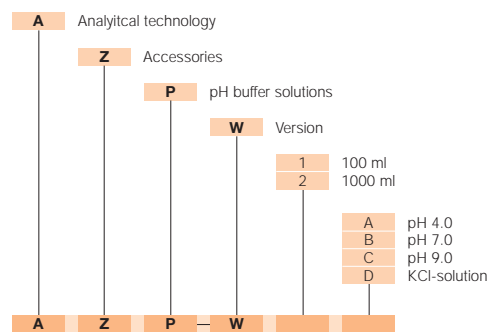

● **Technical ORP buffer solutions model AZR-W**

For calibrating the ORP electrodes.

Volume: 250 mL

220 mV ± 5 mV (at 25 °C)

468 mV ± 5 mV (at 25 °C)

Type codes AZR-W

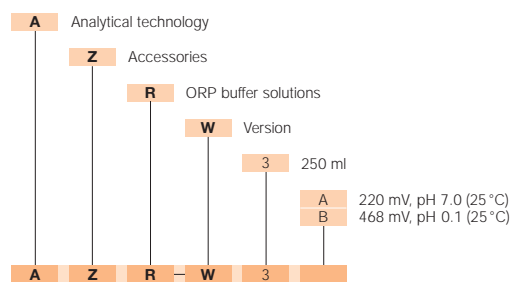

● **Precision calibration solutions for conductivity model AZC-W**

For calibrating conductivity measuring cells
A quality certificate is supplied.

Volume: 500 mL

74.0 µS/cm ± 0.5 % (at 25 °C)

1.406 mS/cm ± 0.5 % (at 25 °C)

107.0 mS/cm ± 0.5 % (at 25 °C)

Type codes AZC-W

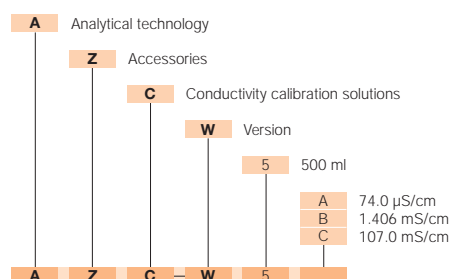

Temperature sensors

● **Temperature sensors in the form of a pH electrode model AZT-Z (compact line)**

The temperature sensor model AZT-Z is used for temperature compensation, when the measuring sensors for pH value or conductivity have no built-in temperature sensor. It should be used with the transmitters from the compact line APM-Z for pH value, ARM-Z for ORP and ACM-Z for conductivity. Coaxial cable APK-Z5K can be used for connection to the transmitter.



Measuring element:	Pt 100
Range:	-10 ... +135 °C
Length of body:	120 mm
Diameter of body:	12 mm
Connection head:	conduit thread 13.5
Pressure rating:	up to 10 bar

● **Temperature sensor in the form of a pH electrode model AZT-X (expert-line)**

The temperature sensor model AZT-X is used for temperature compensation, when the measuring sensors for pH value or conductivity have no built-in temperature sensor. It should be used with the transmitters from the expert line APM-X for pH value and ORP, and ACM-X for conductivity. Coaxial cable APK-X5S can be used for connection to the transmitter.



Measuring element:	Pt 100
Range:	-15 ... +150 °C (pH 0...14)
Length of body:	120 mm
Diameter of body:	12 mm
Connection head:	conduit thread 13.5
Pressure rating:	up to 10 bar

Wall and Pipe Mounting Brackets

● **Wall and Pipe Mounting Brackets for the pH-, ORP- and conductivity transmitters in a field-housing; Model AZM**

A 2" pipe and two wall mounting brackets are available for the field housing.

Bracket for Wall Mounting (fix)

Allows mounting either vertically or horizontally
 Model AZM-W
 for use with the Expert Line field housing only.
 Material: Aluminium, Synthetic

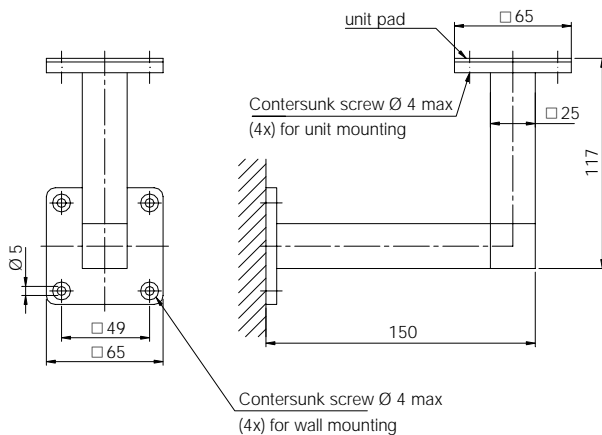

Bracket for Wall Mounting (360° rotation)

The field housing can be rotated through 360 degrees allowing easy viewing when mounted in any plane
 Model AZM-S
 for use with the Compact Line and Expert Line field housing
 Material: Aluminium, Synthetic, Stainless Steel 1.4301

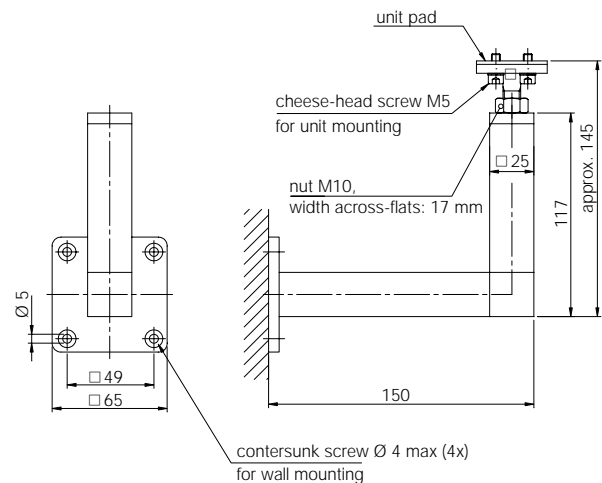

Bracket for Pipe Mounting

Suitable for 2" pipes
 Model AZM-R
 for use with the Compact Line and Expert Line field housing
 Material: Stainless Steel 1.4571

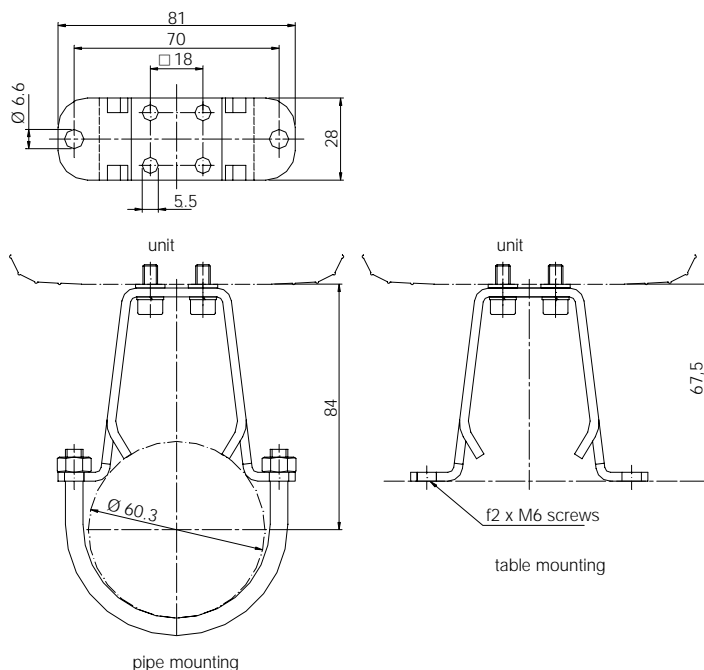

Type code AZM

