



PASSIVE 4÷20MA HUMIDITY AND TEMPERATURE TRANSMITTERS WITH CONFIGURABLE TEMPERATURE WORKING RANGE

DESCRIPTION

HD 2007T... and HD 2008T... are microprocessor configurable humidity and humidity-temperature 4÷20 mA transmitters. The temperature range is configurable. They convert humidity and temperature values into two linear current signals (2 wires) in the field 4÷20 mA. In the humidity-temperature combined version, the two circuits and the related outputs are completely independent one from the other. The linearization based on digital technique grants best accuracy and stability. Programming is carried out very easily by pressing a button. No operation by means of jumpers, potentiometers, etc. is requested. The humidity input can be recalibrated using two saturated solutions: **the first one** at 75%, the **second one** at 33%; the 0% R.H...100% R.H. relative humidity range is fixed and 4 mA correspond to 0% R.H., while 20 mA to 100% R.H. In HD 2008 model, the operator can configure 4÷20 mA (or 20÷4 mA) temperature output in any range going from -50°C up to +200°C with 25°C minimum amplitude. A LED indicates the alarm states (temperature exceeding set-point, sensor failure or short-circuit) and helps the operator when programming. Important remark: the relative humidity sensor may work in a -40...+150°C temperature range. Beyond this range till +180°C it can work for brief periods.

TECHNICAL DATA (@ 20°C e 24 Vdc)

		HD 2007	HD 2008
Relative humidity input	Model		MK 33
	Capacity		300pF nom.
	Accuracy at 20°C		±2% (5±90%) ±2.5% (in the remaining range)
	Relative humidity operating range		5...98% R.H.
	Temperature operating range of relative humidity sensor		-40...+150°C - compensated
	Wire length		TC version = 1.5 m, 5 m and 10 m
	Working static pressure of sensor		20 bar
When using the transmitter, check sensor compatibility with the atmosphere where it is installed			
Temperature input	Sensor	----	Pt100, 100 Ω at 0°C (α=0.00385)
	Connection	----	3 (or 2) wires
	Transducer energized	----	<1 mA
	Measuring range	----	-50...+200°C
	Accuracy 20°C	----	±0.1°C ±0.1% of reading
Output	4...20 mA R.H.	0...100% R.H.	0...100% R.H.
	4...20 mA Temperature	----	Configurable in the range -50...200°C (min. amplitude: 25°C)
	22 mA	In case of faulty programming, of disconnected probe or of temperature exceeding selected range. The alarm red LED is lighted. (**)	
	Linearization	Digital	
Power supply for every input		7...30 Vdc	
Maximum load (see fig. 3)		$R_{Lmax} = 770 \Omega$ a 24 Vdc $R_{Lmax} = \frac{(Vdc-7)}{22 \text{ mA}}$	
Response time (*)	No filter	6 seconds	
	With filter	3 minutes	
Working temperature electronics		-10...+70°C	
Electronics protection class		IP 67	

(*) Time necessary to reach 63% of total variation

(**) In the event that measured temperature "T" exceeds T1...T2 (T1<T2) selected range, temperature transmitter holds 4 mA for T<T1 and 20 mA for T>T2 for a 10°C dead band before going on error at 22 mA.

INSTALLATION AND CONNECTION

Figure 11 shows the mechanical dimensions of the transmitters and the holes to fix the case. Figures 1 and 2 show current loop connection diagram. The RL (load) symbol identifies any device part of the current loop, that is: either a panel meter, a controller, a data logger or a recorder. Measure accuracy is not affected by the position of the transmitter. However, it is suggested to install the transmitter with the sensor oriented downwards to minimize dust settling on sensor protection filter. The transmitter shall not be mounted neither near a heating source - as heating air causes a decrease in relative humidity (by the same quantity of water vapour) - nor near doors, in presence of rushes of air; but movements of air mustn't miss.

When using the transmitter, check sensor compatibility with the atmosphere where it is installed.

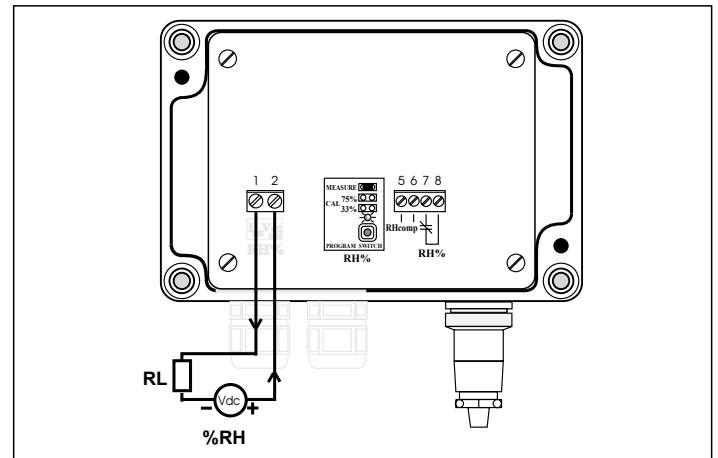

Fig.1 Connection diagram of relative humidity single transmitter

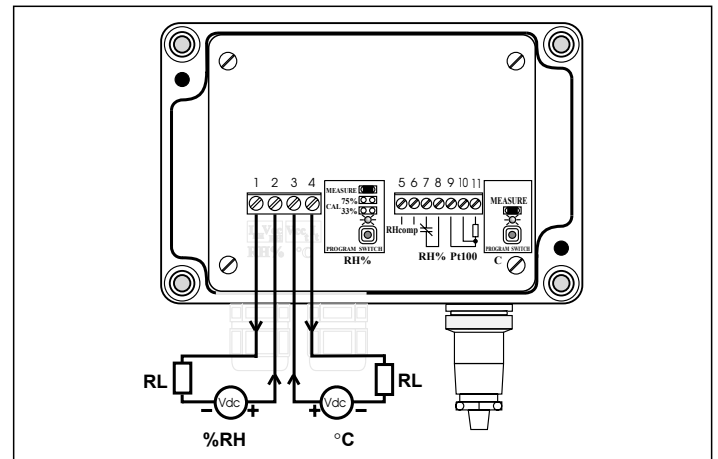

Fig. 2 Connection diagram of relative humidity and temperature combined transmitter

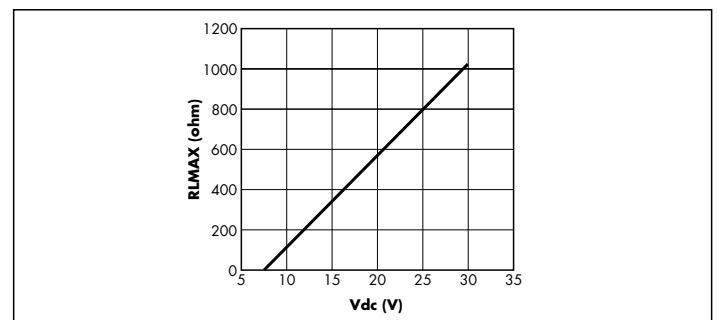

Fig. 3 Load resistance as a function of power supply

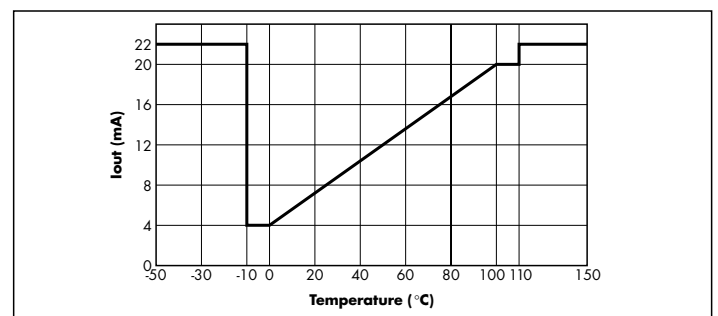

Fig. 4 Range 0...100°C, 4÷20 mA temperature output.

MOUNTING

The instrument is offered in three different configurations to meet any applicative need.

They are:

TO horizontal version, suitable for duct installations; an adjustable connection fitting is available for wall or duct mounting (1/2" gas thread).

TV vertical version suitable for wall-mounting

TC version with wire. The sensor is connected to the electronics by means of a differently long wire. It can work in a temperature range from -40°C up to +150°C.

Attention: in TC models the sensor and the electronics have the same serial number. They can be exchanged with other transmitters only if the instrument is recalibrated with the new sensor.

PROGRAMMING

The transmitters of HD 2007T... and HD 2008T... series are supplied with relative humidity and temperature sensors calibrated with current outputs and a 4...20 mA range. **4 mA corresponds to 0% R.H. and to 0°C; 20 mA corresponds to 100% R.H. and to 100°C.** The user can re-calibrate the humidity sensor (holding the 4 mA = 0% and 20 mA = 100% R.H. correspondence) and set a different temperature output range.

A) Humidity Sensor Calibration

The following accessories are requested: a 7÷30 Vdc continuous power supply, a best accuracy ammeter with 0...25 mA min. range.

The calibration of the humidity sensor is executed on two fixed points, 75.4% R.H. - always the first point - and 33% R.H. - the second point -, according to the following instructions:

- power the instrument as shown in the connection diagrams of Figure 1 (HD 2007T...) and Figure 2 (HD 2008T...);
- put the sensor inside the case containing the 75% R.H. saturated solution and wait for 30 minutes, at least;
- move the jumper from "MEASURE" to "CAL 75%" position;
- press the small key "Program Switch R.H." and hold it for 5 seconds until the corresponding LED does not flash. It is now possible to release the key; the LED remains lighted; a sensor put inside the probe compensates the temperature difference of the solution as to 20°C.
- put the sensor in the case containing the 33% R.H. saturated solution and wait for 30 minutes;
- move the jumper to "CAL 33%" position;
- press the small key "Program Switch R.H." and hold it for 5 seconds until the corresponding LED is off. It is now possible to release the key; the ammeter displays a current of 9.28 mA if the solution is at 20°C. But if the temperature of the solution is different, the current displayed by the ammeter has the same value as indicated in the following schedule:

°C	10	15	20	25	30	35	40	45	50
% R.H.	33.4	33.3	33	32.7	32.4	32	31.6	31.1	30.5
mA	9.34	9.33	9.28	9.23	9.18	9.12	9.06	8.98	8.88

- move again the jumper on "MEASURE". The calibration of the R.H. probe is over.
- Important remark: the first calibration point has to be always at 75% R.H.**

B) 4÷20 mA temperature output programming HD 2008T... models only

The following accessories are requested:

- 7÷30 Vdc continuous power supply,
- Calibration of Pt100 or of a set of best accuracy resistances,
- Best accuracy ammeter with 0...25 mA min. range.

Procedure:

- Connect HD 2008T... temperature section as shown in fig. 2, set Pt100 calibrator at a temperature corresponding to 4 mA. For example: let's suppose to adjust a -10...+120°C range and, consequently, to set the calibrator at -10°C; the equivalent resistance value will be 96.09 Ω; if the calibration is carried out with a fixed resistance, between terminals 10 and 11, being terminals 9 and 10 short-circuited, a 96.09 Ω fixed resistance will be connected.
- Wait 10 seconds in order to get a steady measurement, press "Program Switch °C" programming key for 5 seconds, until the led flashes once and then remains lighted;
- Set Pt100 calibrator at the value established for 20 mA. According to the above mentioned example, the calibrator setting shall be +120°C; the equivalent resistance value will be 146.07 Ω; if the calibration is carried out with a fixed resistance, between terminals 10 and 11, being terminals 9 and 10 short-circuited, a 146.07 Ω fixed resistance will be connected.
- Wait 10 seconds in order to get a stable measurement, press for 5 seconds the "Program Switch °C" key until the LED is off. When releasing the key, the LED will flash twice to confirm programming has been executed. The SET POINT procedure is over.
- Check that the configuration meets requested specifications by setting the calibrator at the values corresponding to 4 and 20 mA (or connecting the precision resistances) and checking current in the ammeter.



Holder HD 9008.21.2 + HD 9008.26/14 125 mm.



Holder HD 9008.21.1 - HD 9008.26/14 250 mm.



HD 9008.31 flange with sensor block.

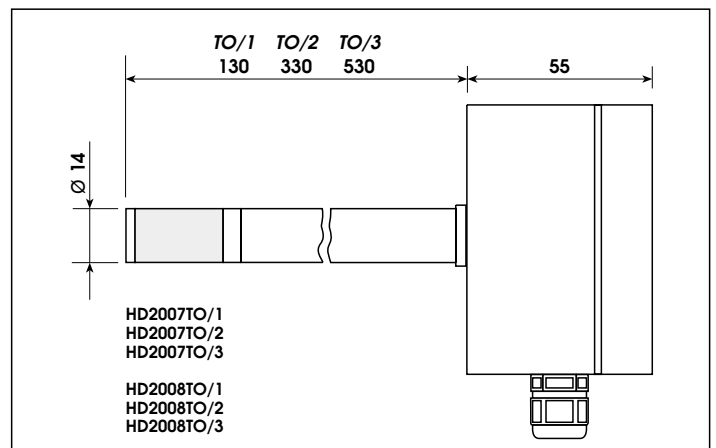

Fig. 8 TO version: mechanical dimensions

ORDER CODES

- HD 2007TO/1:** relative humidity 2-wire passive transmitter, 4±20 mA output. Duct horizontal fixed sensor L=130 mm.
- HD 2007TV:** relative humidity 2-wire passive transmitter, 4±20 mA output. Wall-mounting vertical fixed sensor.
- HD 2007TC/1:** relative humidity 2-wire passive transmitter, 4±20 mA output. Sensor L=130 mm connected directly to the instrument by means of a 1.5 m long wire.
- HD 2007TC/2-5:** relative humidity 2-wire passive transmitter, 4±20 mA output. Sensor L=330 mm connected directly to the instrument by means of a 5 m long wire.
- HD 2007TC/2-10:** relative humidity 2-wire passive transmitter, 4±20 mA output. Sensor L=330 mm connected directly to the instrument by means of a 10 m long wire.
- HD 2008TO/1:** relative humidity and temperature duct configurable 2-wire passive combined transmitter, 4±20 mA double output. Duct fixed horizontal sensor L=130 mm.
- HD 2008TV:** relative humidity and temperature duct configurable 2-wire passive combined transmitter, 4±20 mA double output. Wall-mounting fixed vertical sensor.
- HD 2008TC/1:** relative humidity and temperature duct configurable 2-wire passive combined transmitter, 4±20 mA double output. Sensor L=130 mm connected directly to the instrument by means of a 1.5 m long wire.
- HD 2008TC/2-5:** relative humidity and temperature duct configurable 2-wire passive combined transmitter, 4±20 mA double output. Sensor L=330 mm connected directly to the instrument by means of a 5 m long wire.
- HD 2008TC/2-10:** relative humidity and temperature duct configurable 2-wire passive combined transmitter, 4±20 mA double output. Sensor L=330 mm connected directly to the instrument by means of a 10 m long wire.
- HD75:** saturated salt solution 75% R.H. with adapter M 12x1
- HD33:** saturated salt solution 33% R.H. with adapter M 12x1
- HD9008.21.1:** holder for vertical sensor, wall distance 250mm, hole Ø 26. Use with reduction HD9008.26.14
- HD9008.21.2:** holder for vertical sensor, wall distance 125mm, hole Ø 26. Use with reduction HD9008.26.14
- HD9008.26/14:** reduction for Ø 26 and Ø 14mm holes, for HD9008.21.1 and HD9008.21.2
- HD9008.31:** flange with sensor block Ø 14mm for duct sensors of the series TC and TO.

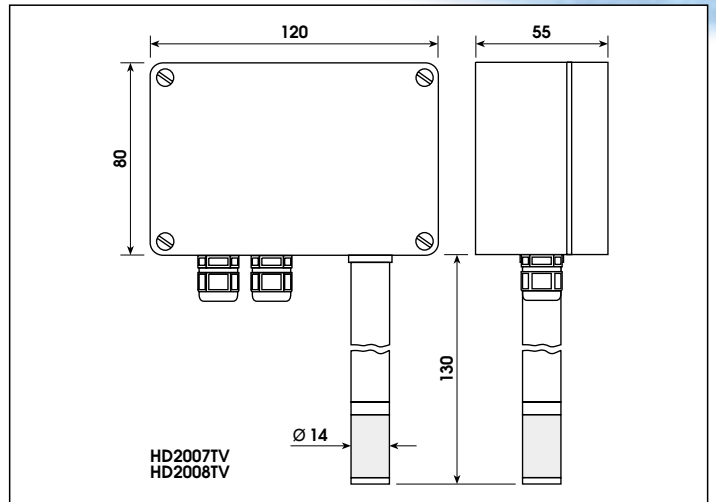

Fig. 9 Mechanical dimensions version TV.

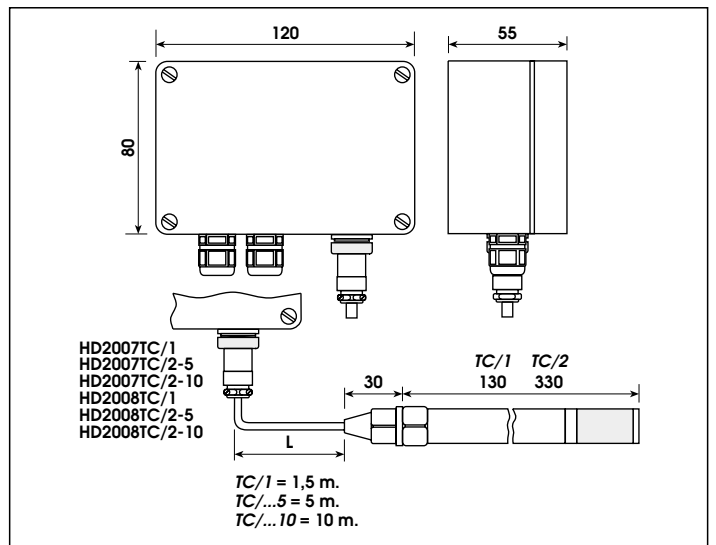
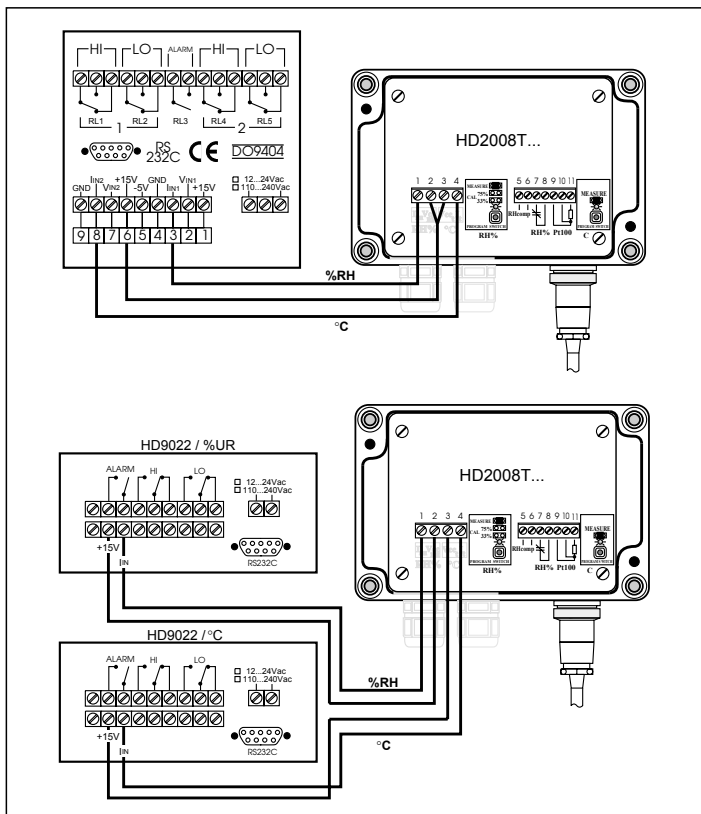
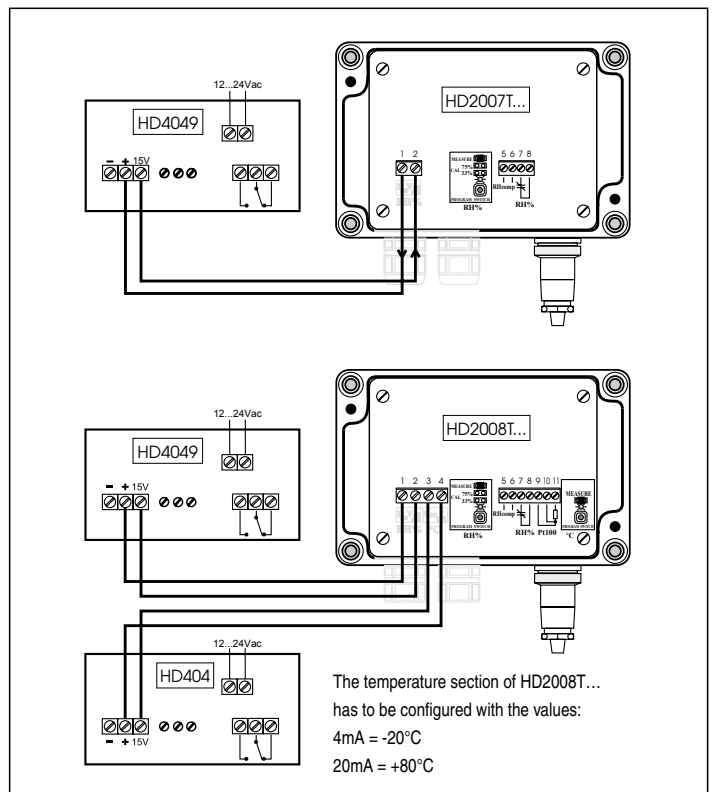

Fig. 10 Mechanical dimensions version TC.



Example of connection of transmitters HD2008T with the indicators HD9022 and DO9404.



Example of connection of transmitters HD2007T... and HD2008T with the indicators HD404 and HD4049.