

PNI SEN-L Magneto-Inductive Sensor

General Description

PNI Corporation's Magneto-Inductive (MI) sensors are based on patented technology that delivers breakthrough, cost-effective magnetic field sensing performance. These sensors change inductance by 100% over their field measurement range. This variable inductance property is used in a patented temperature and noise stabilized oscillator/counter circuit to detect field variations. The PNI 11096 ASIC is the recommended implementation of this patented circuit, and can be used with the Sen-L to construct a magnetometer with up to 3-axes.

Advantages include low voltage and power, small size leaded package, large signal noise immunity under all conditions, and a large dynamic range. Resolution and field measurement range are software configurable for a variety of applications. The measurement is very stable over temperature and inherently free from offset drift.

These advantages have made PNI Corporation's MI sensors the choice for a wide variety of applications.

Features

- Low power: draws < 500 μ A at 3 VDC
- Small size: 14 x 4 mm (length x diameter)
- Large field measurement range: $\pm 550 \mu$ T (± 5.5 Gauss)
- High resolution field measurement: 0.0055 μ T (0.000055 Gauss)
- Few external components: 11096 ASIC with two resistors per sensor.
- Leaded component for through hole mounting

Applications

- Handheld battery-powered devices with built-in compass feature.
- High performance magnetic field sensing.
- High performance solid state navigation equipment for automotive, marine, and aeronautic applications.
- Direction finding features for any device where bearing or attitude indicators have value.
- Magnetic object proximity sensing.

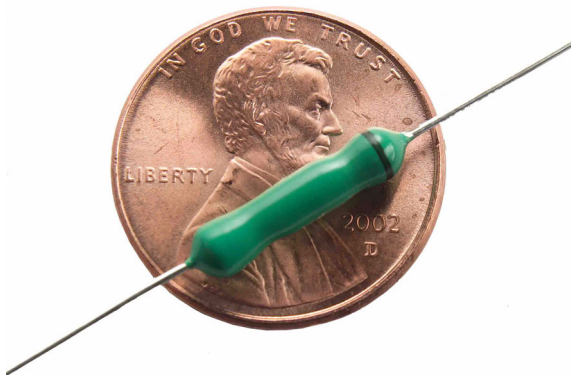

Ordering Information

Part Number	Minimum Order Quantity	Package
10165	<1000	Each
10165	1000	Bulk

Specifications

CAUTION

Stresses beyond those listed under [Table 1](#) may cause permanent damage to the device. These are stress ratings only. Functional operation of the device at these or any other conditions beyond those indicated in the operational sections of the specifications is not implied. Exposure to absolute maximum rating conditions for extended periods may affect device reliability.

Table 1. Absolute Maximum Ratings

Symbol	Parameter	Maximum
V_{COIL}	Voltage across coil	2.5 VDC
V_{B}	Coil breakdown voltage	200 VDC
I_{IN}	Input pin current	20 mA at 25 °C
T_{STRG}	Storage temperature	-55 °C to 130 °C

Table 2. Sensor Characteristics

Parameter	Minimum	Maximum	Typical
DC resistance at 25 °C ^a	110 Ω	130 Ω	120 Ω
DC resistance versus temperature		0.5% / °C	0.4% / °C
Inductance ^b	1.75 mH	5.25 mH	
Q factor ^c	0.1	0.2	
Operating Temperature	-30 °C	80 °C	
Storage Temperature	-55 °C	130 °C	

a. Determined with a DC source.

b. No DC bias, 100 kHz at 1 V_{p-p}, orthogonal to Earth's magnetic field.

c. Measured with an LCR meter.



Table 3. Sensor Characteristics with PNI 11096 ASIC

Parameter	Minimum	Maximum	Typical
Current (Measured at ASIC V_{cc})			
3 VDC, $R_b = 100 \Omega$		0.5 mA RMS	0.35 mA RMS
5 VDC, $R_b = 150 \Omega$		0.5 mA RMS	0.35 mA RMS
Field measurement range ^a			
3 VDC, $R_b = 100 \Omega$	-550 μ T	550 μ T	
5 VDC, $R_b = 150 \Omega$	-550 μ T	550 μ T	
Gain ^b			
3 VDC, $R_b = 100 \Omega$			22.90 count/ μ T
5 VDC, $R_b = 150 \Omega$			15.44 count/ μ T
Linearity (error from best fit straight line at $\pm 100 \mu$ T)			1%
Resolution			1/gain μ T
Frequency 3VDC, $R_B = 100 \Omega$ (Within free Earth's magnetic field.)	50 kHz	90 kHz	
Operating Temperature (when used with PNI 11096)	-20 °C	70 °C	

- a. Field measurement range is defined as the monotonic region of the output characteristic curve.
- b. Gain is defined as the change in the number of counts from the ASIC, when the period select is set to 512, per change in the magnetic field in μ T. For situations requiring higher gain and less field measurement range, the gain and resolution can be increased by a factor of 2 by setting the ASIC period select to 1024. When setting higher period selects, be aware that the ASIC counter can overflow if the field is strong enough to drive the count beyond a signed 16-bit integer. Period select set to 1024 is the highest setting where it is impossible to overflow the counter.

For more information, see “PNI-11096, 3-Axis Magneto-Inductive Sensor Driver and Controller with SPI Serial Interface” data sheet.



Typical Operating Characteristics: Sen-L (3VDC; Rb = 100 Ω)

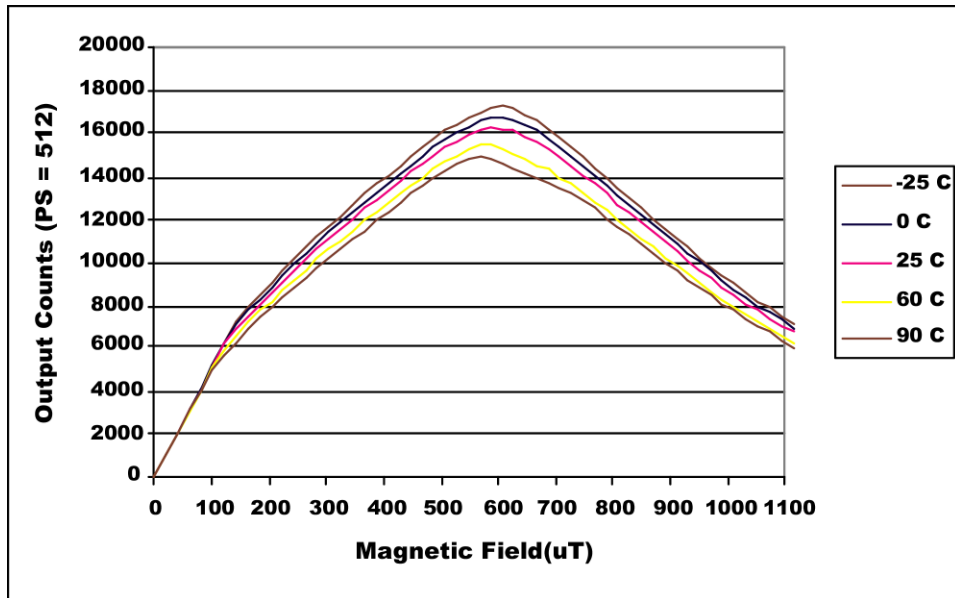

Figure 1. Temperature Characteristics

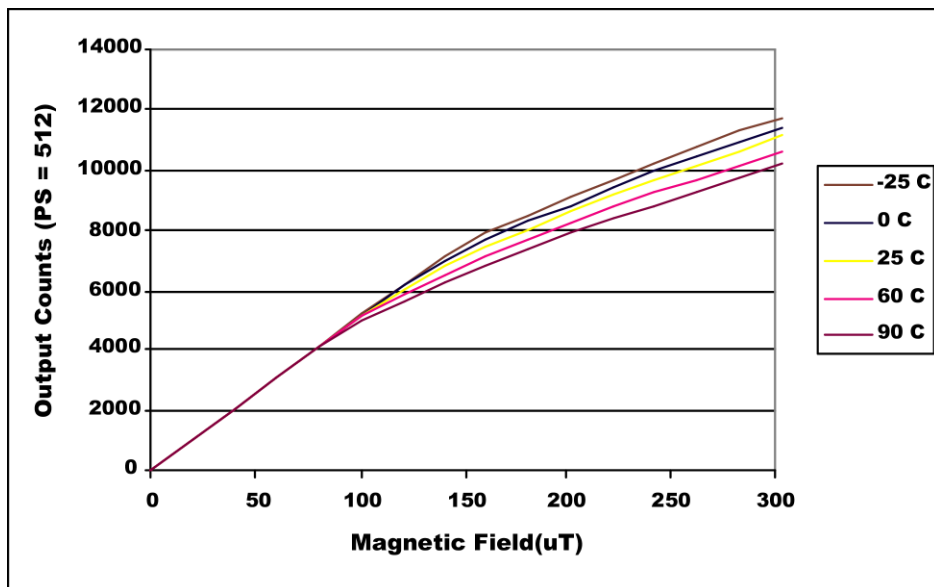

Figure 2. Linearity versus Temperature

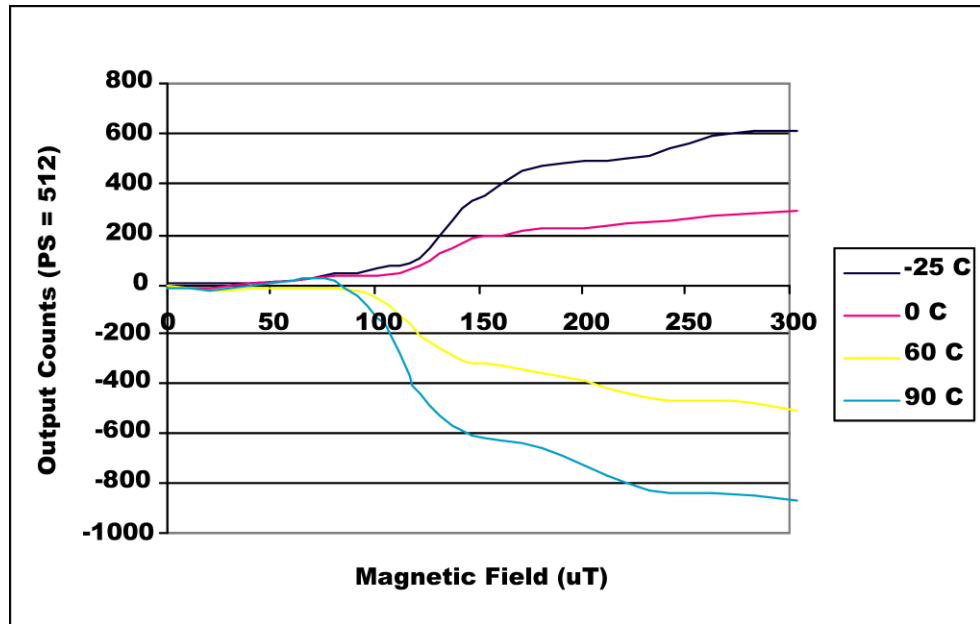
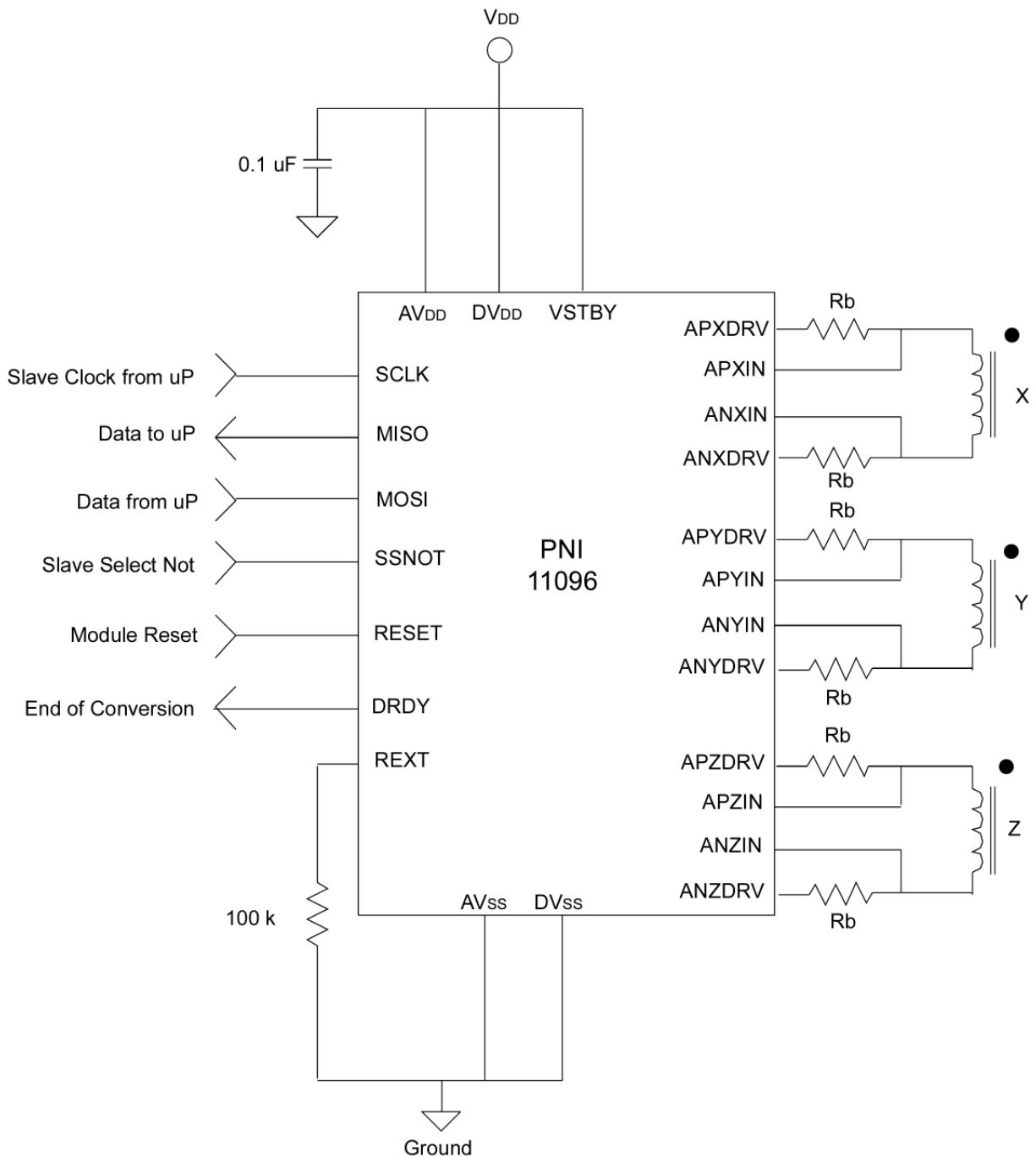

Figure 3. Linearity versus Temperature, Normalized to Room Temperature (RMT)

Output Counts is defined as the Period Select (PS) setting for the 11096 ASIC. For more information, see “PNI-11096, 3-Axis Magneto-Inductive Sensor Driver and Controller with SPI Serial Interface” data sheet.

Recommended Circuit Block Diagram

**Figure 4. Block Diagram**

Rb is dependent on the supply voltage.

5 VDC: Rb = 150 Ω

3 VDC: Rb = 100 Ω



Package Information

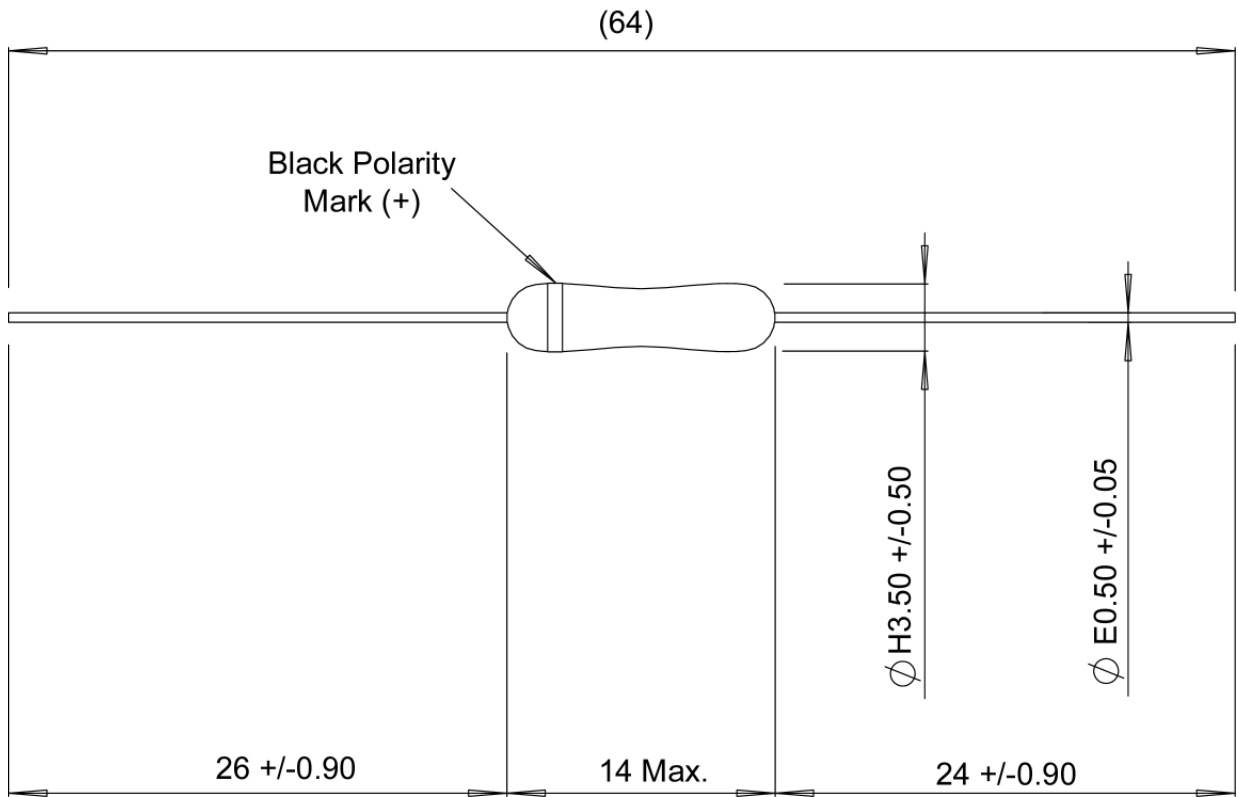

All units are in millimeters.

Figure 5. Outline Dimensions

Sensor Lead Bending Instructions

Tools Required:

- Needle nose pliers
- Ohm meter

Procedure

- 1 With the needle nose pliers, grip the sensor lead, next to the body of the sensor so that the pliers cover a minimum of 2 mm of the lead. The actual length is to be determined by the application, but will never be less than 2 mm. Refer to [Figure 6](#).
- 2 Using your fingers, slowly bend the lead to 90 ° from the sensor while maintaining a hold on the lead with the pliers.
- 3 Repeat [Step 1](#) and [Step 2](#) on the other lead, being careful to keep the second lead parallel to the first.
- 4 After both leads have been bent, take a resistance reading of the sensor. If the reading is between 110 Ω and 130 Ω, the sensor is still operational.

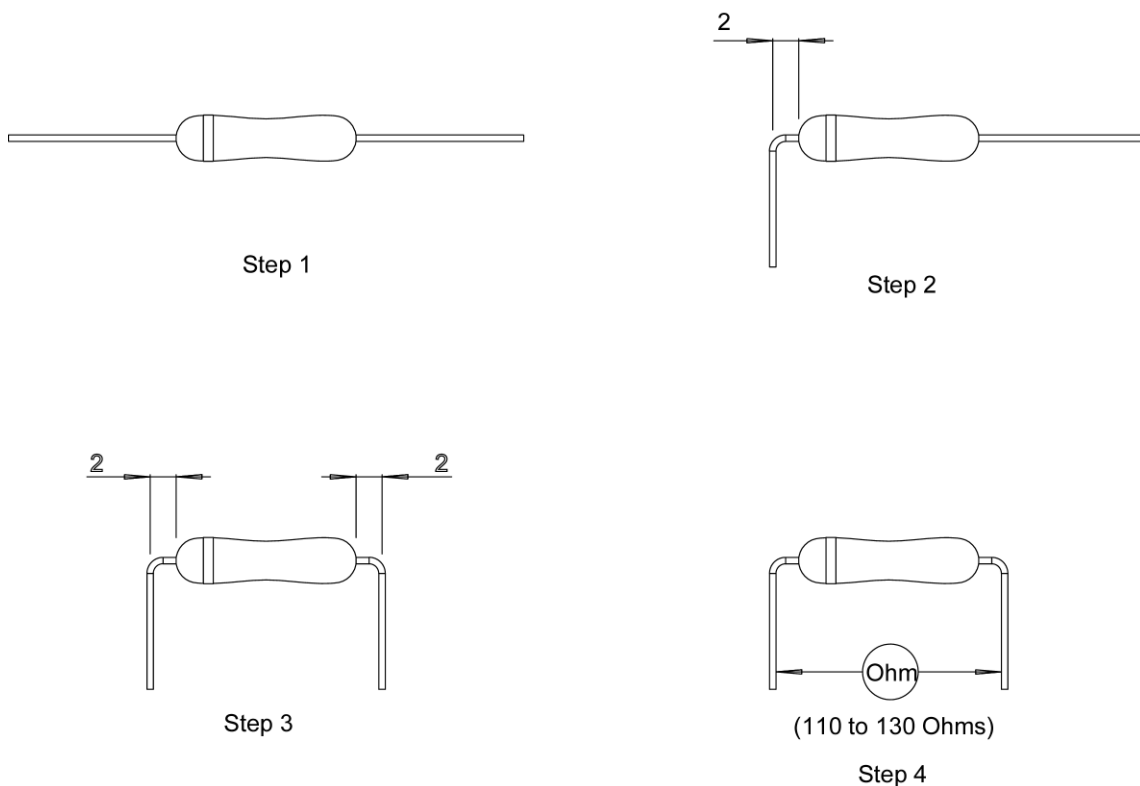

Figure 6. Sensor Lead Bending